

# XNote AI User Guide

**Disclaimer:**

XNote AI is continuously updated with new features and improvements. Some features described in this guide may be available as beta and are subject to change. Screenshots and interface elements may differ slightly from the current version of the app.

# Content

<b>XNote AI User Guide</b> .....	<b>1</b>
<b>Content</b> .....	<b>2</b>
<b>1. Get Started</b> .....	<b>9</b>
1.1 Unboxing & What's Included.....	9
1.2 Know Your Pen.....	10
1.3 LED Status Indicators.....	12
1.4 Charge & Power On.....	14
1.5 Holding the Pen & Writing.....	16
1.6 Download the XNote App.....	17
<b>2. XNote Mobile</b> .....	<b>18</b>
2.1 Account & Authentication.....	18
2.1.1 Sign Up (Create an Account).....	18
2.1.2 Sign In (Existing Account).....	21
2.1.3 Forgot Password.....	22
2.1.4 After Sign In Initial Sync.....	26
2.2 Onboarding (Language, Handedness, Preferences).....	27
2.3 Pair Your Pen (Bluetooth Connection).....	35
2.4 Set Your Primary Notebook.....	39
2.5 Home.....	43
2.5.1 Pen Status.....	44
2.5.2 Notebooks View.....	49
2.5.3 Folders View.....	50
2.5.4 Activity Tabs.....	51
2.5.4.1 Upcoming Events.....	52
2.5.4.2 Meetings.....	53
2.5.4.3 Recordings.....	54
2.5.4.4 Tasks.....	55
2.5.5 Task Screen.....	56
2.5.6 Upcoming Events.....	57
2.6 Notebooks & Pages.....	59
2.6.1 View Notebooks.....	59
2.6.2 Create a Notebook.....	60
2.6.3 Set Primary Notebook.....	62
2.6.4 Pin a Notebook.....	62
2.6.5 Browse Pages.....	65
2.6.6 View Page Details (Canvas & Text).....	66
2.6.7 Edit Page Content.....	76
2.6.8 Delete a Notebook.....	77

2.7 Pen Settings & Factory Reset.....	79
2.7.1 Pen Settings.....	79
2.7.2 Factory Reset.....	81
2.8 Audio Sessions.....	86
2.8.1 Manual Recording.....	87
2.8.2 Meeting Bot (Send Bot to Meeting).....	91
2.8.3 Audio Session Detail.....	97
2.8.4 Summary & Templates.....	103
2.8.5 Speaker Identification & Renaming.....	105
2.8.6 Action Items.....	106
2.8.7 Link Pages to Recording.....	107
2.8.8 Share & Audio Minutes.....	109
2.9 AI Chat.....	111
2.9.1 Start a Conversation.....	111
2.9.2 Mention Pages in Chat.....	115
2.9.3 Summarize.....	117
2.9.4 Flashcards.....	120
2.9.5 Translation.....	123
2.9.6 Chart Generation.....	125
2.9.7 Mind Map Generation.....	128
2.9.8 Chat History.....	132
2.10 Search.....	134
2.10.1 Full-Text Search.....	135
2.10.2 Topic-Based Search.....	136
2.10.3 Tag-Based Filtering.....	137
2.10.4 Recent Searches.....	138
2.11 Tasks.....	139
2.11.1 View & Filter Tasks.....	139
2.11.2 Create / Edit / Delete Tasks.....	141
2.11.3 Sort & Search Tasks.....	142
2.11.4 Todoist Integration.....	143
2.12 Events & Calendar.....	150
2.12.1 Calendar View & List View.....	151
2.12.2 Google Calendar Integration.....	153
2.12.3 Event Details.....	156
2.12.4 Meeting Bot Scheduling.....	160
2.13 Automations.....	164
2.13.1 View Automations.....	164
2.13.2 Create an Automation.....	165
2.13.3 Edit an Automation.....	170
2.13.4 Automation Templates.....	171

2.13.5	Connected Services (Google, Slack).....	172
2.13.6	Automation History.....	174
2.14	Folders & Tags.....	175
2.14.1	Create & Manage Folders.....	175
2.14.2	View All Folders.....	177
2.14.3	Folder Detail (View Pages in a Folder).....	178
2.14.4	Add Pages to Folders.....	179
2.14.5	Create & Manage Tags.....	181
2.14.6	Tag Pages.....	182
2.15	Share & Export.....	183
2.15.1	Share a Page (Link).....	183
2.15.2	Share a Recording (Link).....	184
2.15.3	Manage Shares.....	185
2.15.4	Export a Notebook.....	186
2.15.5	Export Pages (PDF, PNG, SVG, DOCX, Markdown).....	187
2.15.6	Bulk Export (Multiple Pages).....	189
2.16	Offline Sync.....	191
2.16.1	Home Screen Sync Banner.....	191
2.16.2	Sync from Pen.....	192
2.16.3	Sync Progress & Results.....	195
2.16.4	Sync Status.....	196
2.17	Settings.....	197
2.17.1	Profile.....	198
2.17.2	Email & Notifications.....	199
2.17.3	Password & Security.....	203
2.17.4	Pen & Notebooks.....	204
2.17.5	Integrations.....	207
2.17.6	Automations.....	227
2.17.7	General.....	227
2.17.8	Accessibility.....	228
2.17.9	Support & Resources.....	229
2.17.10	Account Deletion.....	230
2.17.11	App Updates.....	231
2.17.12	Rate App.....	231
2.17.13	Sign Out.....	231
2.18	Subscription.....	231
2.18.1	View Current Plan.....	231
2.18.2	Usage Tracking (Audio Minutes, Workflows).....	233
2.18.3	Upgrade via Paywall.....	235
2.18.4	Buy More Minutes.....	236
2.18.5	Redeem Code.....	237

2.18.6 Manage & Restore.....	238
2.19 Stroke History.....	240
2.19.1 What is Stroke History?.....	240
2.19.2 How to Open.....	241
2.19.3 Understanding the Timeline.....	242
2.19.4 Two Ways to Delete.....	243
2.19.4a Cut After.....	243
2.19.4b Range Delete.....	245
2.19.4c Use this when.....	246
2.19.5 Preview Tabs.....	247
2.19.6 Recovery.....	248
2.19.7 Moving Strokes to Another Notebook.....	250
2.19.8 Important Information.....	253
2.19.9 Quick Reference.....	254
2.19.9 FAQ.....	254
2.20 Notification Settings.....	255
2.21 Inbox.....	256
2.22 Customize.....	258
<b>3. XNote Web.....</b>	<b>260</b>
3.1 Open XNote Web.....	260
3.2 Account & Authentication.....	261
3.2.1 Sign Up (Create an Account).....	261
3.2.2 Sign In (Existing Account).....	266
3.2.3 Forgot Password.....	267
3.3 Onboarding (Language, Handedness, Preferences).....	269
3.4 Pair Your Pen (Bluetooth Connection).....	275
3.5 Set Your Primary Notebook.....	278
3.6 Home.....	280
3.6.1 Sidebar & Pen Connection.....	281
3.6.2 Notebooks View.....	283
3.6.3 Folders View.....	284
3.6.4 Recent Recordings.....	284
3.6.5 Tasks Overview.....	285
3.6.6 Upcoming Events.....	286
3.6.7 Note Taker Panel.....	288
3.7 Notebooks & Pages.....	289
3.7.1 View Notebooks.....	289
3.7.2 Create a Notebook.....	290
3.7.3 Set Primary Notebook.....	292
3.7.4 Pin a Notebook.....	293
3.7.5 Browse Pages.....	294

3.7.6 View Page Details (Canvas & Text)	295
3.7.7 Edit Page Content	302
3.7.8 Delete a Notebook / Page	303
3.8 Pen Settings & Factory Reset	304
3.8.1 Pen Settings	304
3.8.2 Factory Reset	305
3.9 Meetings & Audio Sessions	306
3.9.1 Meeting Bot (Send Bot to Meeting)	307
3.9.2 Audio Session Detail	308
3.9.3 Summary & Templates	310
3.9.4 Speaker Identification & Renaming	310
3.9.5 Action Items	311
3.9.6 Link Pages to Recording	312
3.9.7 Share & Audio Minutes	313
3.9.8 Meeting Status	315
3.9.9 Uploads	316
3.9.10 Guide	317
3.10 AI Chat	318
3.10.1 Start a Conversation	318
3.10.2 Mention Pages in Chat	320
3.10.3 Summarize	322
3.10.4 Flashcards	323
3.10.5 Translation	325
3.10.6 Chart Generation	327
3.10.7 Chat History	329
3.10.8 Mind Map Generation	330
3.11 Search	332
3.11.1 Full-Text Search	332
3.11.2 Topic-Based Search	333
3.11.3 Tag-Based Filtering	334
3.11.4 Recent Searches	335
3.12 Tasks	335
3.12.1 View & Filter Tasks	335
3.12.2 Create / Edit / Delete Tasks	337
3.12.3 Sort & Search Tasks	338
3.12.4 Todoist Integration	339
3.13 Events & Calendar	341
3.13.1 Calendar View & List View	341
3.13.2 Google Calendar Integration	342
3.13.3 Event Details	344
3.13.4 Meeting Bot Scheduling	344

3.14 Automations.....	345
3.14.1 View Automations.....	345
3.14.2 Create an Automation.....	346
3.14.3 Edit an Automation.....	348
3.14.4 Automation Templates.....	349
3.14.5 Connected Services (Google, Slack).....	349
3.14.6 Automation History.....	350
3.15 Folders & Tags.....	351
3.15.1 Create & Manage Folders.....	351
3.15.2 View All Folders.....	352
3.15.3 Folder Detail (View Pages in a Folder).....	353
3.15.4 Add Pages to Folders.....	353
3.15.5 Create & Manage Tags.....	354
3.15.6 Tag Pages.....	354
3.16 Share & Export.....	355
3.16.1 Share a Page (Link).....	355
3.16.2 Share a Recording (Link).....	356
3.16.3 Manage Shares.....	357
3.16.4 Export Pages (PDF, PNG, SVG, DOCX, Markdown).....	358
3.16.5 Bulk Export (Multiple Pages).....	359
3.17 Offline Sync.....	361
3.17.1 Home Screen Sync Banner.....	361
3.17.2 Sync from Pen.....	362
3.17.3 Sync Progress & Results.....	364
3.18 Settings.....	365
3.18.1 Profile.....	366
3.18.2 Email & Notifications.....	367
3.18.3 Password & Security.....	368
3.18.4 Connected Accounts.....	369
3.18.5 Pen & Notebooks.....	370
3.18.6 Integrations.....	370
3.18.7 Support & Resources.....	371
3.18.8 Account Deletion.....	372
3.18.9 Sign Out.....	373
3.19 Subscription.....	374
3.19.1 View Current Plan.....	374
3.19.2 Usage Tracking (Audio Minutes, Workflows).....	375
3.19.3 Redeem Code.....	375
3.19.4 Subscription Timeline.....	376
<b>4. Subscription.....</b>	<b>376</b>
4.1 Plans Overview.....	376

4.2 Audio Minutes.....	377
4.3 Add-on Audio Minutes.....	377
4.4 Purchase Channels.....	378
4.5 Upgrade & Downgrade.....	378
4.6 Redeem Code.....	378
4.7 Manage & Restore Purchases.....	379
<b>5. Use Cases.....</b>	<b>380</b>
5.1 Student Lecture to Exam Prep.....	380
5.2 Lawyer Client Meeting to Case File.....	381
5.3 Product Manager Sprint Planning to Stakeholder Update.....	381
5.4 Sales Team Lead Automated Note Distribution.....	382
5.5 Content Creator Automated Publishing Pipeline.....	383
5.6 Operations Manager Task-Driven Team Coordination.....	384
5.7 Consultant Event-Driven Client Schedule.....	384
5.8 Medical Student AI-Powered Study Sessions.....	385
5.9 Business Analyst Data Interpretation & Reporting.....	386
5.10 Researcher Finding Insights Across Field Notes.....	387
<b>6. Frequently Asked Questions (FAQ).....</b>	<b>388</b>
6.1 Smart Pen & Hardware.....	388
6.2 Account & Sign In.....	390
6.3 Notebooks, Pages & Sync.....	390
6.4 Audio & Transcription.....	391
6.5 AI Features.....	392
6.6 Integrations & Automations.....	393
6.7 Subscription & Billing.....	393
6.8 Warranty & Orders.....	393

# 1. Get Started

This section walks you through everything you need to do from unboxing your XNote Smart Writing Set to writing your first digitized note.

## 1.1 Unboxing & What's Included



The XNote Full Set includes:

- XNote Smart Pen : AI-powered smart pen with high-precision dot-pattern technology
- XNote Smart Notebook (Standard : 5.83 × 8.27 in, 192 pages, 7mm line spacing)
- Charging Cable
- User Manual Card

You can also purchase notebooks separately in three sizes:

Size	Dimensions	Pages	Line Spacing
Mini	3.54 × 5.51 in	144	6mm
Standard	5.83 × 8.27 in	192	7mm
Large	9.37 × 6.93 in	192	7mm

Replacement ink refills (D1-type, 0.8mm) and additional notebooks are available at [xnote.ai](https://xnote.ai).

Important: The XNote Smart Pen does not include a built-in microphone. Audio recording and transcription features work through the XNote App on your phone, tablet, or computer.

## 1.2 Know Your Pen

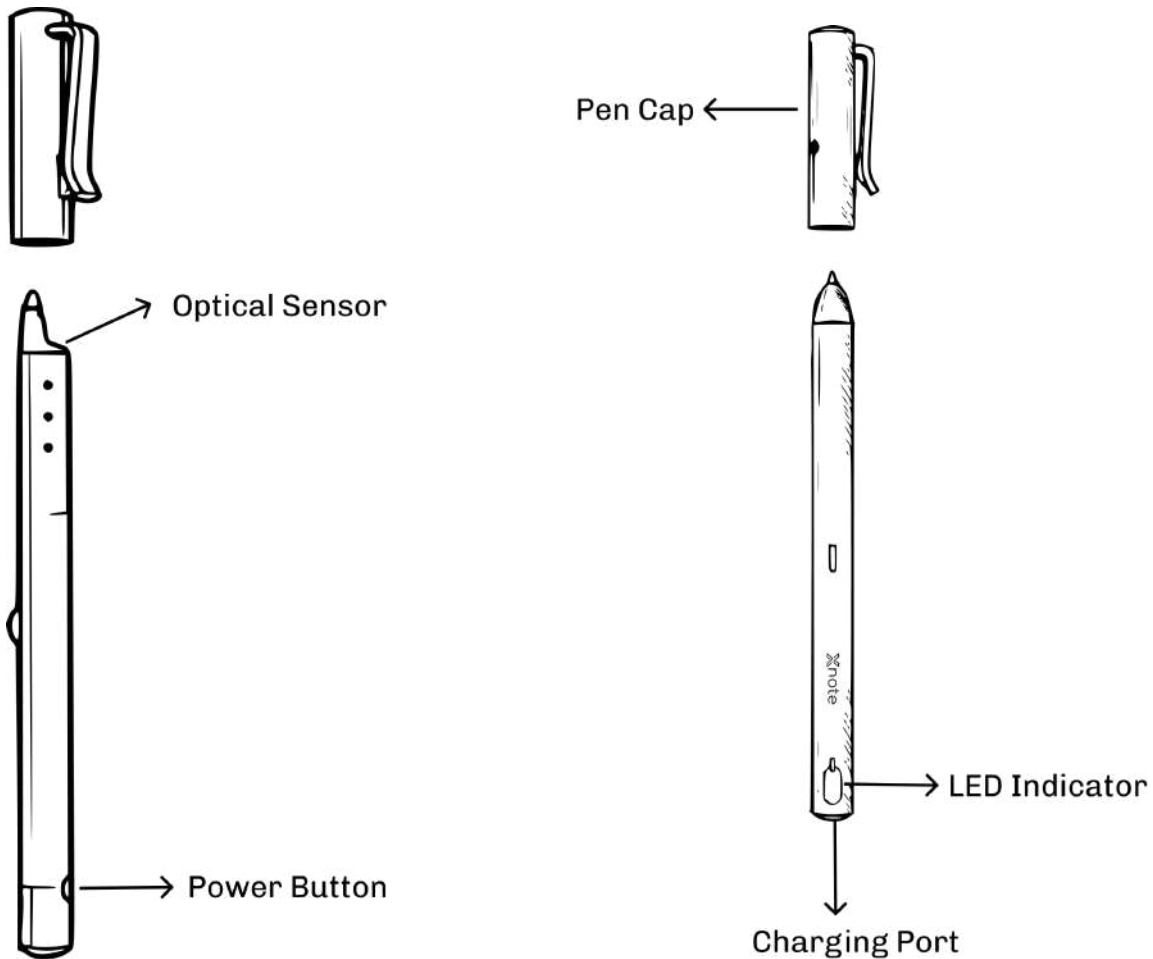











Before you begin, familiarize yourself with your smart pen:

- Power Button : Press to turn the pen on/off (see 1.4).
- Pen Nib & Optical Sensor : The writing tip has a built-in optical sensor that reads dot patterns on XNote notebooks. The sensor (oval-shaped part adjacent to the pen tip) should face downwards during use. A protective nib cover is included remove it before first use.
- LED Indicator : A small light that shows the pen's current status (see 1.3).
- Charging Port : Connect the included cable here to charge the pen.
- Cap : Should be placed on the pen when not in use. Storing the pen without the cap may cause degradation due to dust and foreign substances on the optical sensor.

Ink Refill: The pen uses D1-type refills (0.8mm). To replace, pull the pen tip firmly to remove the old refill and insert a new one. Using a non-recommended refill may cause recognition problems.

## 1.3 LED Status Indicators

Notes:

Status	LED Color	Behavior
Power ON	White 	Solid
Power OFF	Rainbow 	Dimming
Charging	Red 	Illuminating
Fully charged	Green 	Illuminating, then turns OFF
Low battery	Red 	Flashing
Bluetooth standby	Blue 	Flashing
App connection in progress	White 	Dimming
Low storage	Yellow 	Flashing
Firmware update in progress	Blue 	Dimming
Firmware update failed	Orange 	Flashing
Optical sensor issue	Pink 	Solid (with alarms)

- Dimming means the light slowly pulses between dark and bright.
- Optical sensor issue: Check for dirt around the sensor or on the paper surface.

## 1.4 Charge & Power On

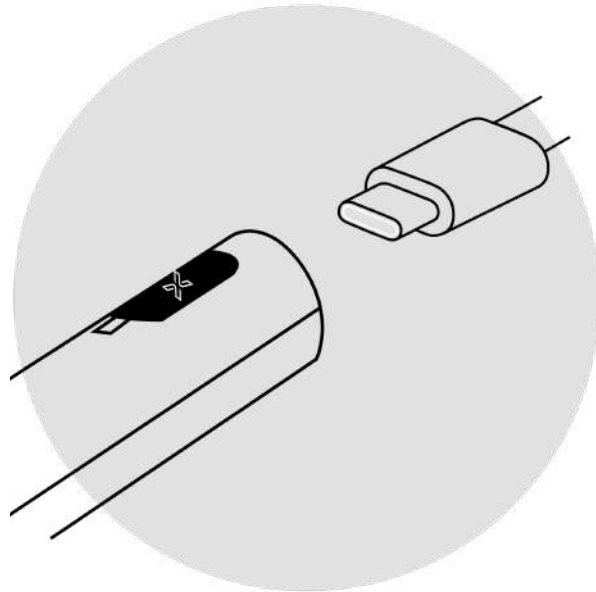

Charge the pen before first use:

1. Plug the charging cable into the pen and connect to a USB power source.
2. The LED will show a steady red light while charging.
3. When fully charged, the LED turns green and then switches off.
4. A full charge takes 2–3 hours and provides up to 17 hours of continuous use.

If there is no LED response when charging, reset the pen and try charging again. If the pen is not used for a long period and becomes completely discharged, it may shorten battery life. Charge frequently for best results.



Turn the pen on:

1. Press the power button : the LED light will turn on in 1 second.
2. To turn off, press and hold for 2 seconds the LED will start flashing and the pen will turn off.
3. If idle for more than 6 hours, the pen turns off automatically. You can adjust the auto-power-off time between 1–10 hours in the XNote app settings.

Auto Power Function: Taking the cap off or starting to write will automatically turn on the pen. Enabled by default; adjustable in the app.

Reset: If the pen does not turn off, won't charge, or stops working, press and hold the power button for 10 seconds. The pen will be turned off and restarted. Internal data will be saved.

## 1.5 Holding the Pen & Writing

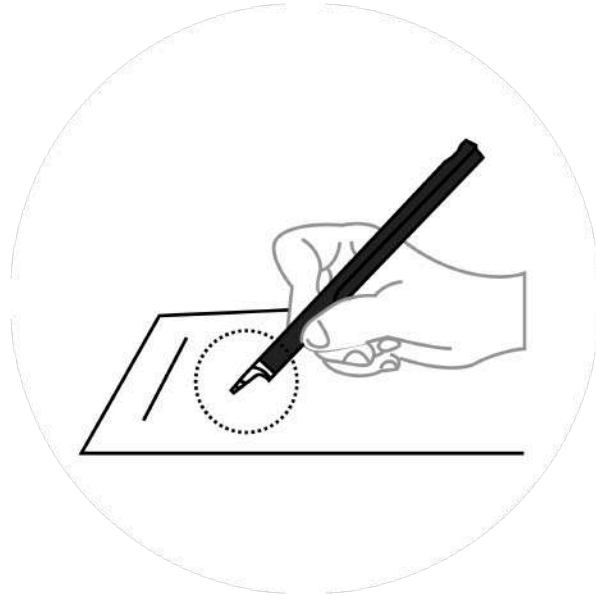

The recognition rate is affected by the optical sensor's angle. For best results:

- Hold the pen so that the sensor faces downwards.
- Maintain a natural writing angle.
- Acceptable recognition angle:  $-20^\circ$  to  $+40^\circ$  ( $90^\circ$  vertical standard).

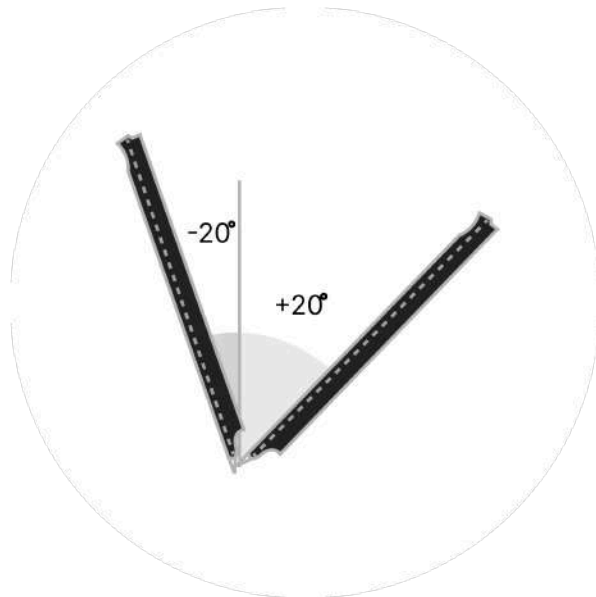



Precautions:

- Direct sunlight may cause loss of recognition.
- Do not cover the optical sensor with your fingers.
- Do not apply pressure to the pen tip.
- Do not write on the edge of the page where there is no dot code.
- If the cap gets dirty, clean with a soft cloth or cotton swab.

## 1.6 Download the XNote App

Download the XNote App to pair your pen, sync your notes, and unlock AI features.

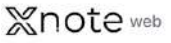
Platform	Where to Download	Requirement
iOS	Search "XNote AI" on the App Store or visit <a href="https://apps.apple.com/app/apple-store/id6499127563">apps.apple.com/app/apple-store/id6499127563</a> 	iOS 15.5+
Android	Search "XNote AI" on Google Play or visit <a href="https://play.google.com/store/apps/details?id=ai.xnote.app">play.google.com/store/apps/details?id=ai.xnote.app</a> 	Android 7.1+
Web	Go to <a href="https://web.xnote.ai">web.xnote.ai</a> 	Web Bluetooth on Chrome & Edge

Setup steps:

1. Download the "XNote" app to your smart device.
2. Enable Bluetooth and GPS (Android) on your device.
3. Follow the on-screen instructions to connect the pen and write in your notebook. The pen LED lights up white dimming when the app and pen are connected.

Once installed, open the app to create your account and pair your pen. For detailed instructions, see XNote Mobile (Section 2) or XNote Web (Section 3).

# 2. XNote Mobile

## 2.1 Account & Authentication

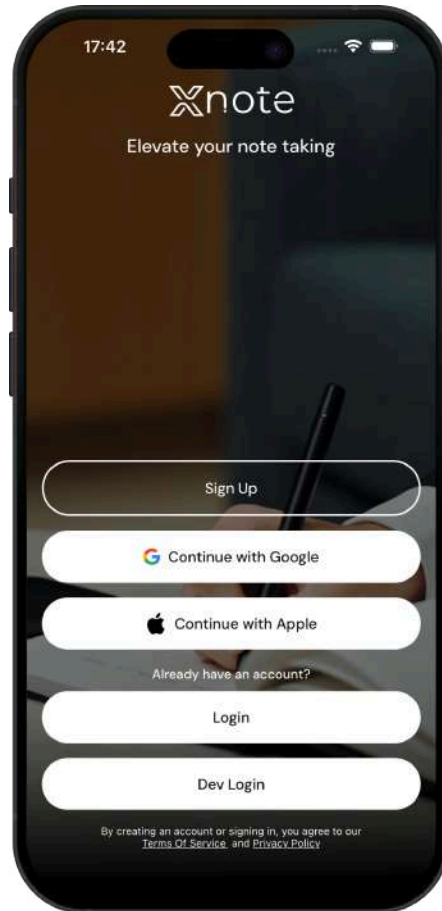

When you first open XNote, the Welcome screen appears with a video background and the XNote logo. From here you can create a new account or sign in to an existing one. Links to the Terms of Service and Privacy Policy are shown at the bottom.

### 2.1.1 Sign Up (Create an Account)

There are three ways to create an XNote account:

- Email
- Continue with Google
- Continue with Apple (iOS only)

## Sign Up with Email:

1. Tap **"Sign Up"** on the Welcome screen.
2. Enter your email address and create a password. Re-enter your password to confirm.

### Password requirements:

- At least 8 characters
- At least one uppercase letter (A-Z)
- At least one lowercase letter (a-z)
- At least one number (0-9)
- At least one special character (!@#\$%^&\* etc.)

17:44

Close

### Let's Start

We need some basic information to verify your identity and create your secure account.

*\* Required fields*

EMAIL \*

PASSWORD \*

RE-PASSWORD \*

Create an account

3. A 6-digit verification code will be sent to your email. Enter the code and confirm. If you didn't receive it, tap **"Resend"** after 60 seconds.

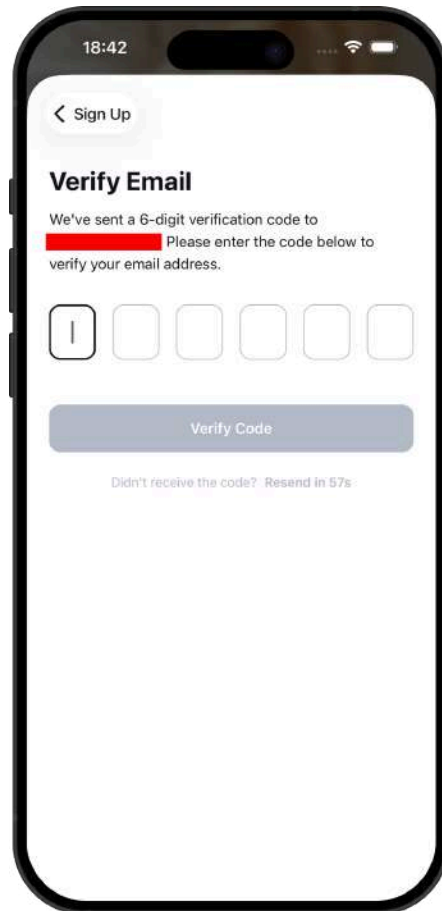

After successful verification, you will be redirected to the Onboarding steps ([see 2.2](#)).

#### **Sign Up with Google:**

Tap **"Continue with Google"**. Select your Google account on the sign-in screen. Once authenticated, you will be redirected to the Onboarding steps.

#### **Sign Up with Apple (iOS only):**

Tap **"Continue with Apple"**. Confirm with Face ID or your password. Your name will be automatically retrieved from your Apple account. Once authenticated, you will be redirected to the Onboarding steps.

## 2.1.2 Sign In (Existing Account)

If you already have an account, tap **"Login"** on the Welcome screen.

### Sign In with Email:

1. Enter your email address and password.
2. Tap **"Login"**.

If your email has not been verified yet, you will be redirected to the OTP verification screen to confirm your email first.

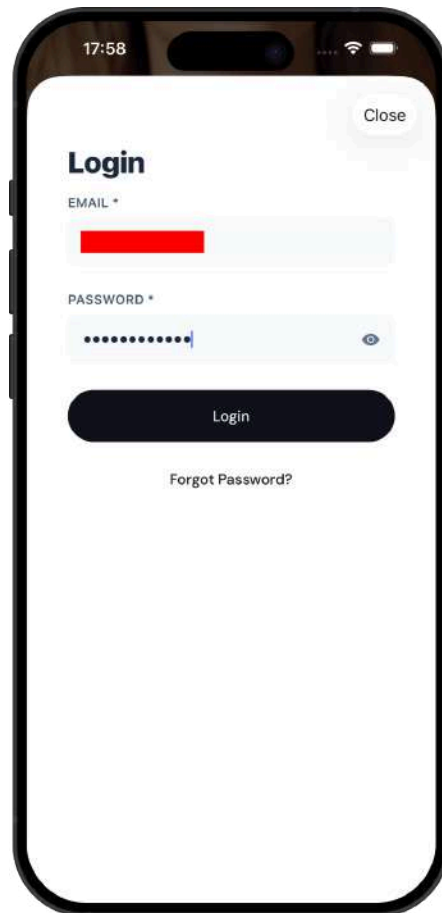

### Sign In with Google:

Tap **"Continue with Google"** on the Welcome screen. Select your Google account. If the account exists, you will be signed in directly.

### Sign In with Apple (iOS only):

Tap **"Continue with Apple"** on the Welcome screen. Confirm with Face ID or your password.

## 2.1.3 Forgot Password

If you forgot your password:

1. On the Sign In screen, tap **"Forgot Password?"**.

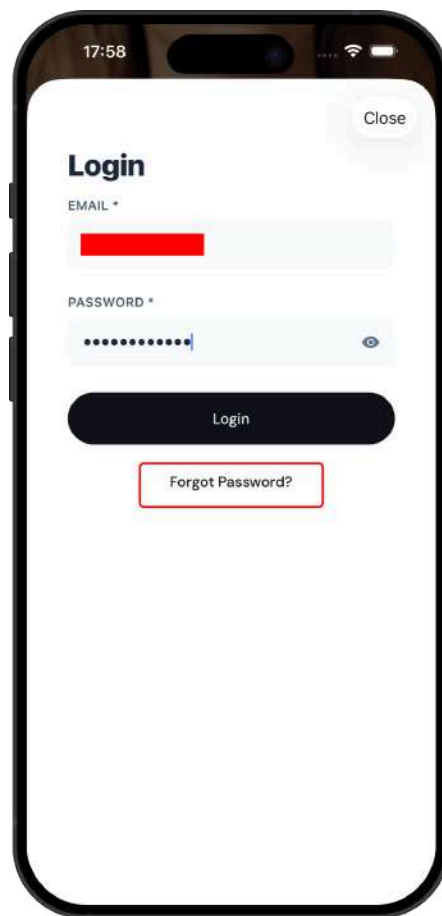

2. Enter your email address and tap **"Reset Password"**. A 6-digit OTP code will be sent to your email.

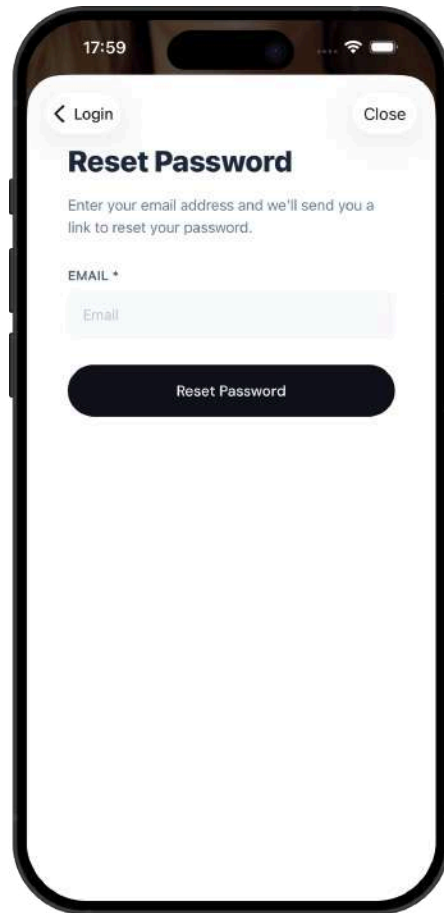

3. Enter the 6-digit code on the verification screen. The code expires after a limited time. If you didn't receive it, tap **"Resend"** after 60 seconds.

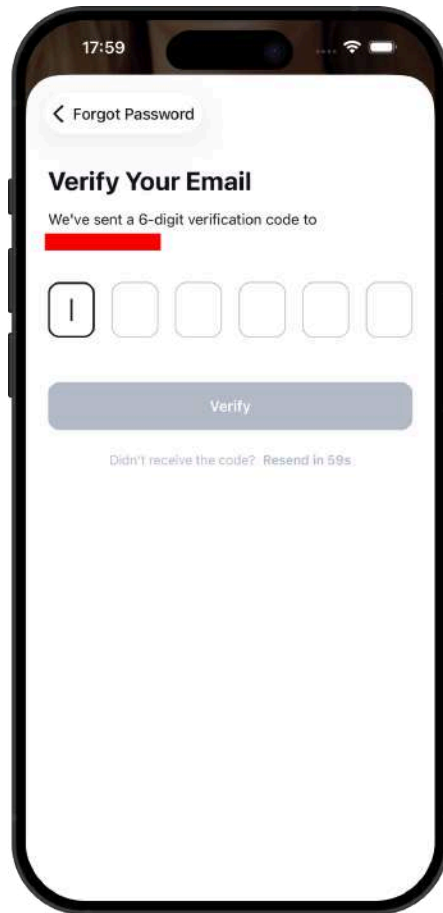

4. After successful verification, a Change Password screen appears. Enter your new password and confirm it. The same password requirements apply (8+ characters, uppercase, lowercase, number, special character).

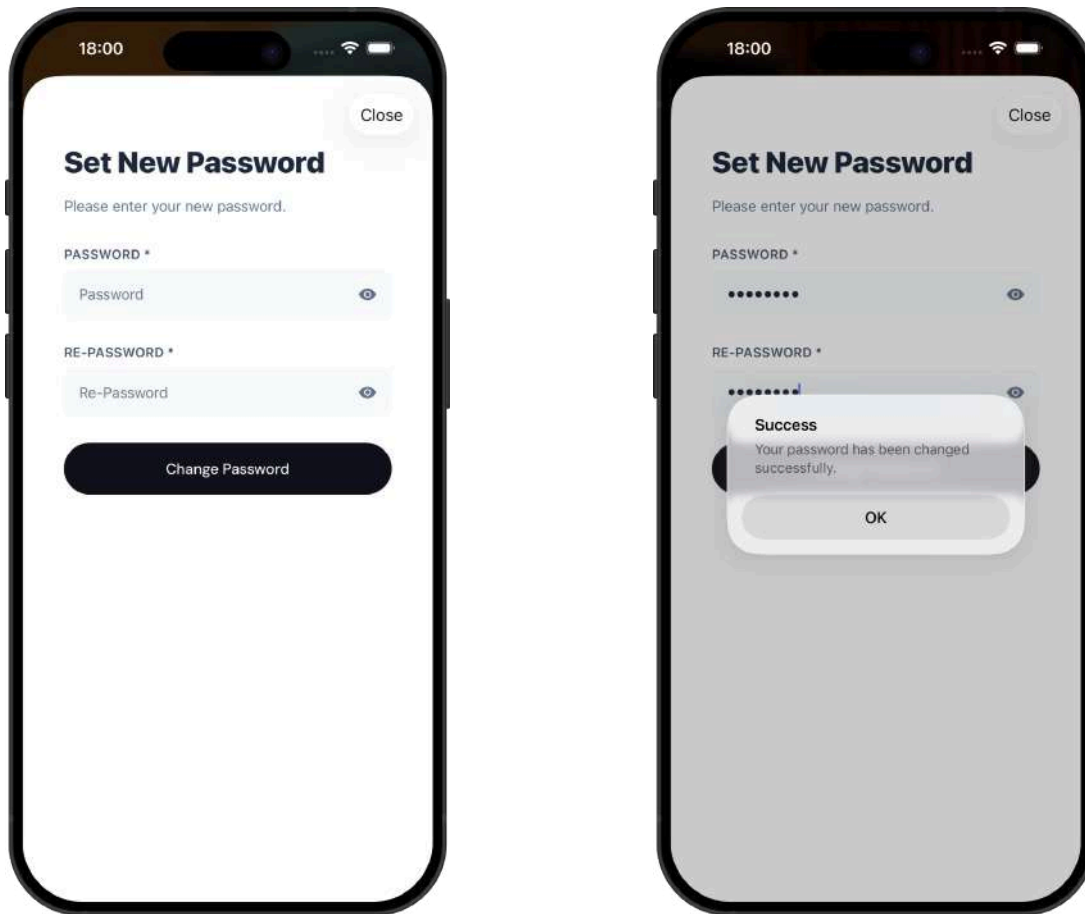

5. After changing your password, you will be signed out and redirected to the Sign In screen. Log in with your new password.

**Tips:**

- Check your spam/junk folder if you don't receive the code
- You can request a new code after a 60-second cooldown
- The OTP code is only valid for a limited time

## 2.1.4 After Sign In Initial Sync

When you sign in to an existing account that has previously synced data, XNote will download your notebooks, pages, and settings. An Initial Sync screen is displayed during this process.

The sync screen shows:

- **"Almost ready"** title with a subtitle **"Setting up your ecosystem"**

- A rotating feature showcase highlighting: AI Integration, Smart Pen, Real-time Sync, Search, and Insights

After sync completes:

- The title changes to **"All set"** with a **"Continue"** button

- Thumbnails and page data are generated locally

- You are then redirected to the Home screen (or Bluetooth pen setup if no pen is connected)

If sync fails, an error message is shown with a **"Retry"** button. Make sure you have an internet connection.

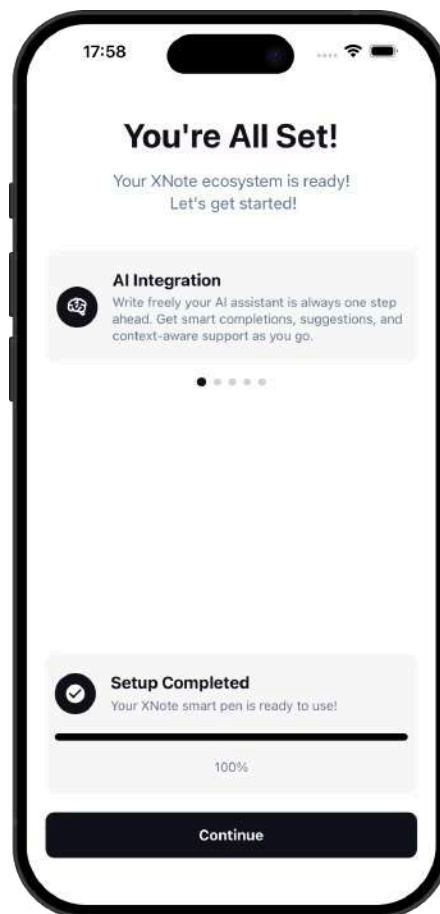

## 2.2 Onboarding (Language, Handedness, Preferences)

After creating your account, XNote guides you through a personalized setup process. This helps tailor the app to your needs.

### Step 1 : Enter Your Name

Enter your full name. A minimum of 2 characters is required.

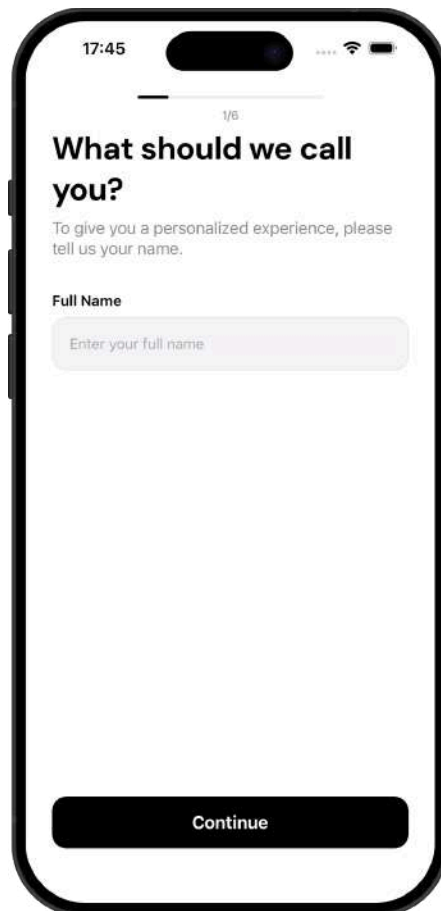

The image shows a mobile phone screen with the following content:

- Top status bar: 17:45, signal strength, Wi-Fi, and battery icons.
- Progress indicator: 1/6.
- Section header: **What should we call you?**
- Subtext: To give you a personalized experience, please tell us your name.
- Label: **Full Name**
- Input field: A rounded rectangular box containing the placeholder text "Enter your full name".
- Bottom button: A black rounded rectangular button with the text "Continue" in white.

## Step 2 : Select Writing Language

Choose your primary writing language from a list of 40 supported languages. You can use the search bar to find your language quickly. Your device language is auto-detected as the default.

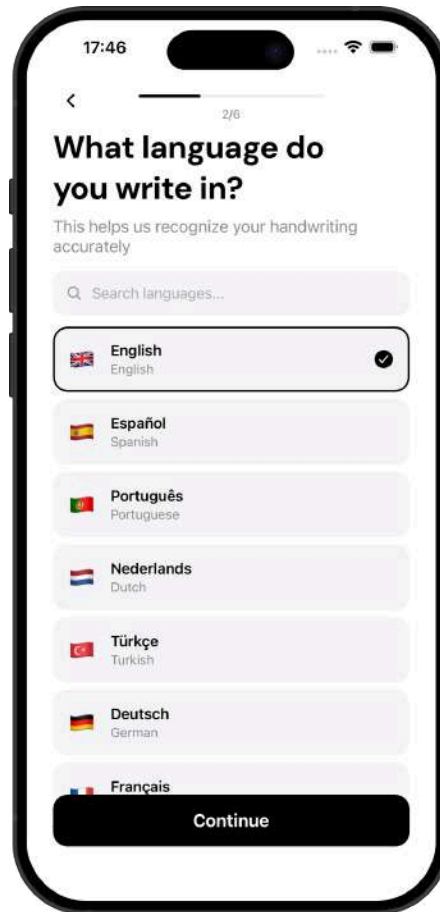

### Step 3 : Select Handedness

Choose whether you are left-handed or right-handed. This preference is used to optimize the pen experience for your writing style.

- Left-Handed: The app adjusts UI element positioning and pen detection to suit left-handed writers.

- Right-Handed: Standard layout with controls positioned for right-handed use.

Tip: If you are a left-handed user who writes in reverse (mirror writing), you can enable the Mirror Writing option later in Pen Settings ([see 2.7.1](#)). This flips the canvas horizontally so you can write naturally from right to left, and ensures your handwriting is correctly recognized by XNote's OCR engine. Note: Most left-handed users write normally and do not need this setting.

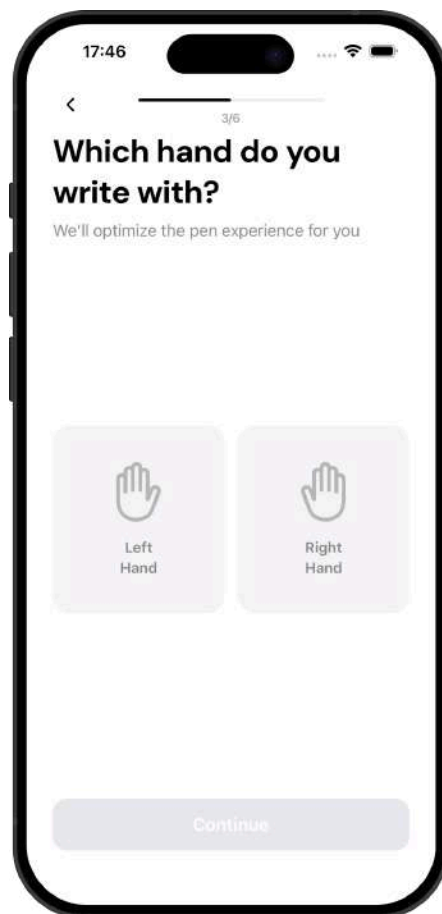

## Step 4 : Main Purpose

Select your primary reason for using XNote:

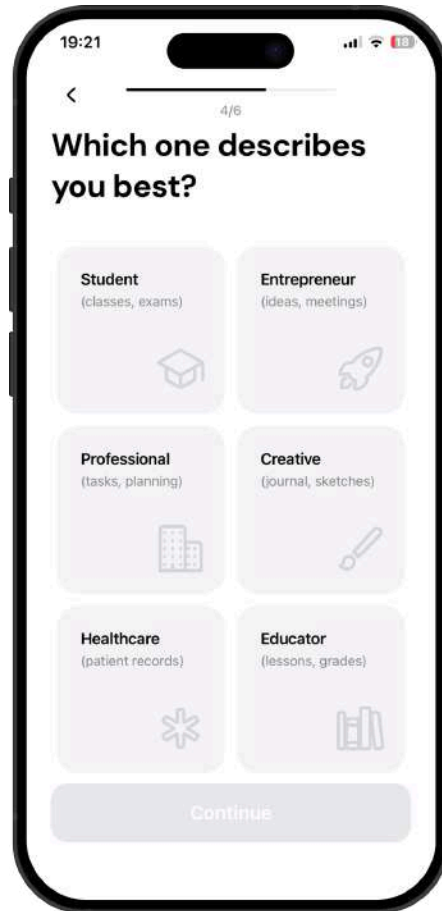

**Step 5 : Note Types**

Select one or more note types that describe how you plan to use XNote:

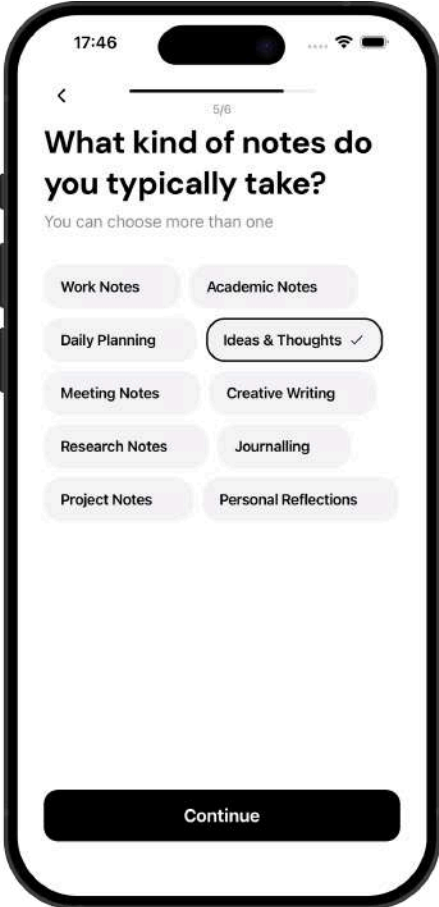

**Step 6 : Note Frequency**

Select how often you take notes:

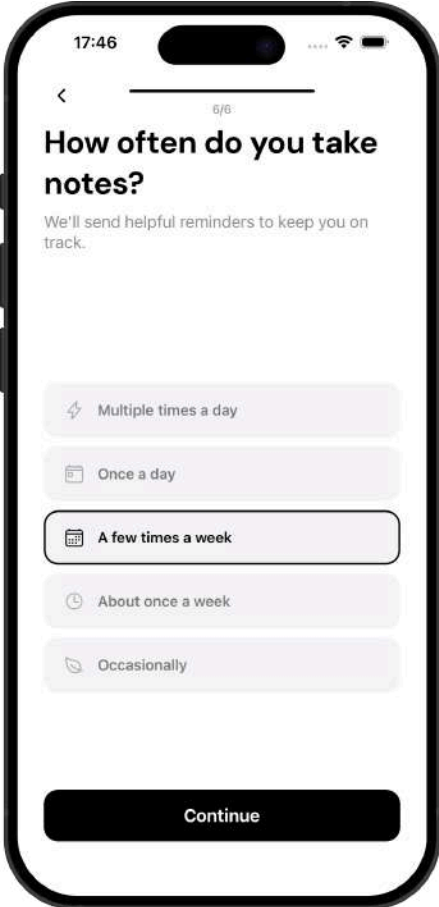

## Step 7 : Pen Setup Guide

A visual 3-step guide shows you how to prepare your XNote Pen:

1. Open the pen cap
2. Locate the Bluetooth indicator light
3. Check the pen nib

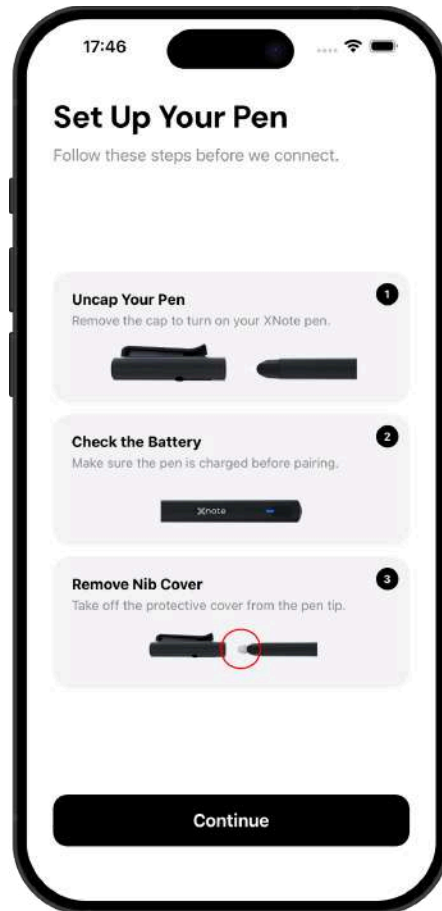

## Step 8 : Bluetooth Permissions

XNote uses Bluetooth Low Energy (BLE) to communicate with your smart pen. Without these permissions, the app cannot discover or connect to your pen, and you will not be able to proceed to the next step.

The screen displays a checklist of required permissions. Each item turns green as it is granted:

### On iOS:

1. Bluetooth Permission : Allow XNote to use Bluetooth in your device settings.
2. Bluetooth Enabled : Turn on Bluetooth from Settings or Control Center.

### On Android:

1. Bluetooth Permission : Grant Bluetooth scan & connect permissions.
2. Bluetooth Enabled : Turn on Bluetooth from your device settings.
3. Location Permission : Required by Android to discover nearby BLE devices.
4. Location Enabled : Turn on Location services.

Important: You cannot skip this step. The **"Start Scanning"** button only appears after all required permissions are granted and services are enabled. If a permission is missing, the app will show a specific action button (e.g., **"Grant Bluetooth Permission"** or **"Open Location Settings"**) to guide you through enabling it.

Why are these permissions needed?

- Bluetooth: Required to discover and connect to your XNote smart pen via BLE.
- Location (Android only): Android requires location permission for BLE device scanning. XNote does not track or store your location this is solely a system requirement for Bluetooth discovery.

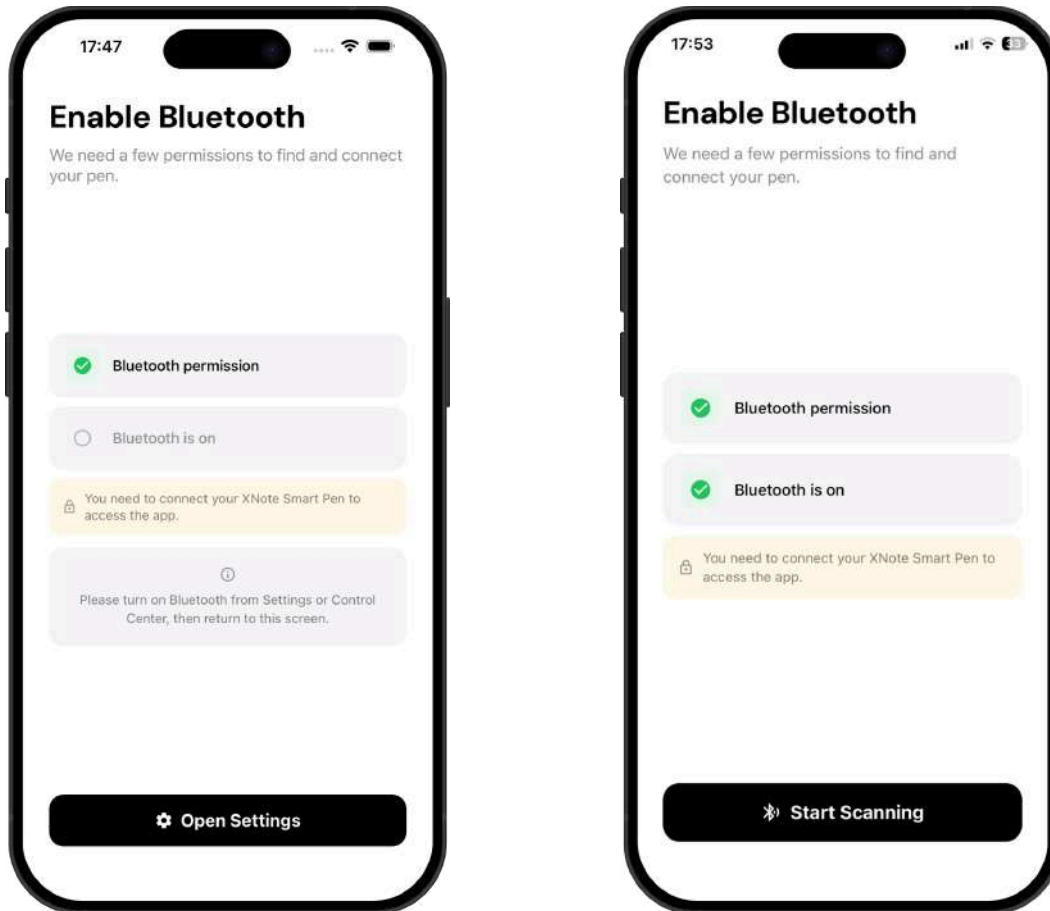

After completing these steps, you will proceed to scan for your pen ([see 2.3](#)).

## 2.3 Pair Your Pen (Bluetooth Connection)

XNote allows you to connect your smart pen via Bluetooth at any time. You can access the scanning screen from the Pen Status Badge on the Home screen ([see 2.5.1](#)) or during the initial onboarding flow.

Make sure your pen is uncapped and Bluetooth permissions are granted before scanning. If this is your first time, these are handled during onboarding ([see 2.2 Steps 7-8](#)).

### Step 1 : Scanning for Your Pen

XNote begins scanning for nearby pens. A pulsing animation will appear while searching. Make sure your pen is uncapped and nearby.

## Step 2 : Select Your Pen

When your pen is discovered, it will appear in a list showing "XNote Smart Pen" with its MAC address. Tap on your pen to start connecting.

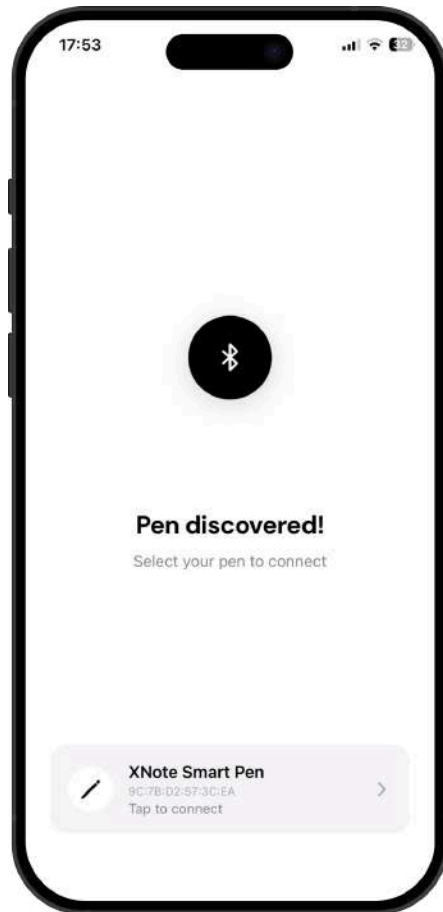

### Step 3 : Connecting

A spinning animation will appear while XNote establishes the connection. This may take a few seconds.

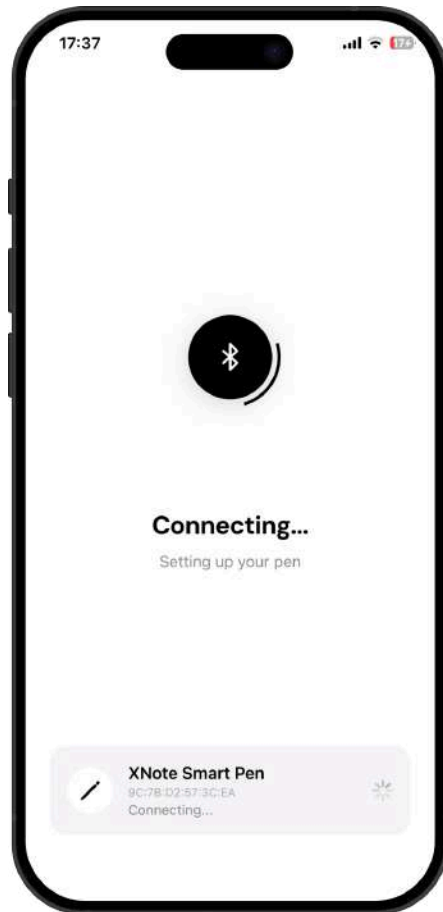

#### Step 4 : Connected

A green checkmark confirms the connection is successful. You will be automatically redirected to the Home screen.

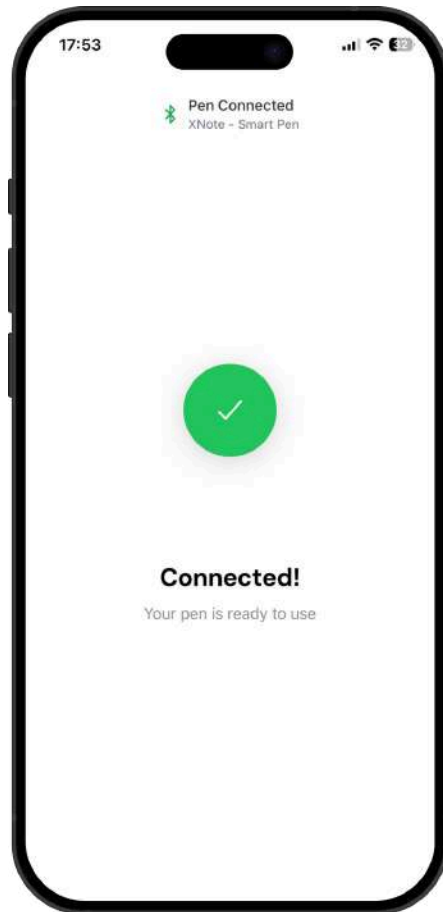

**If connection fails:**

A red icon will appear with the message **"Connection failed"**. Tap **"Try Again"** to restart the scanning process. Make sure your pen is turned on and nearby.

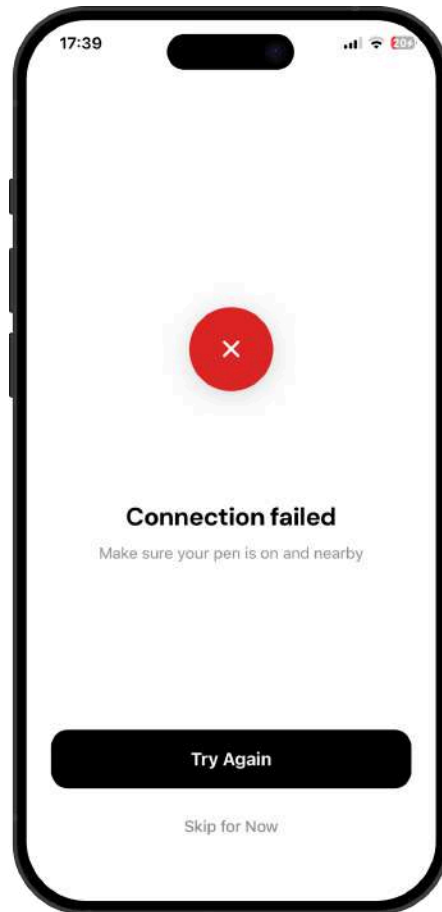

## 2.4 Set Your Primary Notebook

The XNote Smart Pen uses dot patterns on each page to identify your writing. Since notebooks of the same size share identical dot patterns, you need to set a primary notebook for each size so the pen knows where to save your notes.

There are three primary notebook slots:

- Mini (small notebooks)
- Standard (standard notebooks)
- Large (large notebooks)

When you write with your smart pen, your notes will be saved to the primary notebook of the matching size. If no primary notebook is set for a size, a warning banner will appear on relevant screens prompting you to set one.

How to set a primary notebook:

- From Notebook Settings: Tap the three-dot menu on any notebook card and select **"Set as Primary"**. For details, [\(see 2.6.3\)](#).

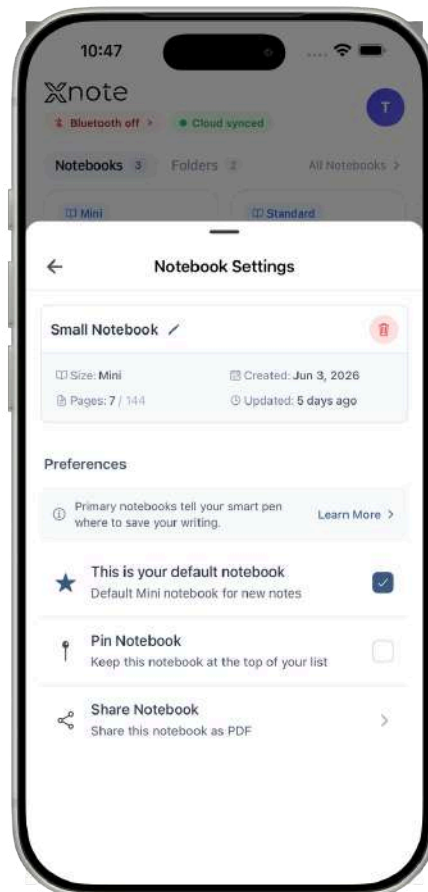

- **From Settings: Go to Settings -> Primary Notebooks** to view and assign a primary notebook for each size in one place. For details, [\(see 2.17.4\)](#).

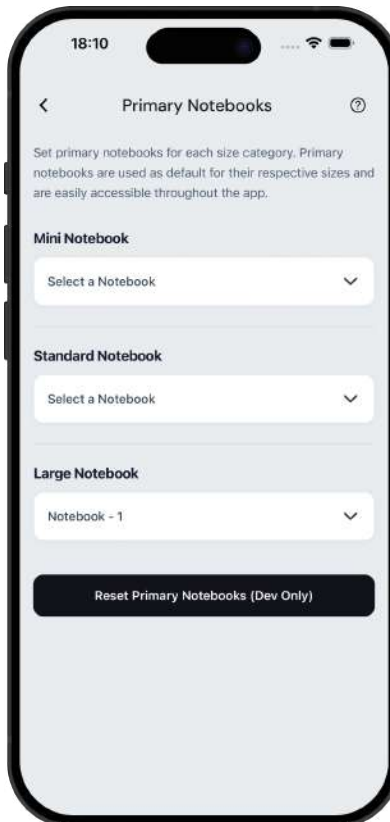

If you create your first notebook of a size, it will automatically be set as your primary notebook.

If you delete a primary notebook, XNote will automatically assign another notebook of the same size as primary.

Tap the info icon in the Primary Notebooks settings header for a help screen explaining when and why to update your selections.

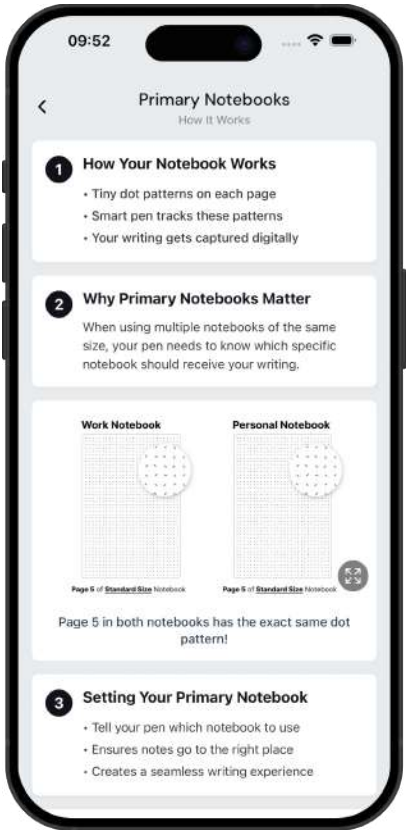

09:52

# Primary Notebooks

How It Works

## 1 How Your Notebook Works

- Tiny dot patterns on each page
- Smart pen tracks these patterns
- Your writing gets captured digitally

## 2 Why Primary Notebooks Matter

When using multiple notebooks of the same size, your pen needs to know which specific notebook should receive your writing.

Work Notebook

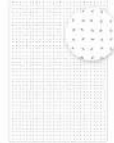

Page 5 of Standard Size Notebook

Personal Notebook



Page 5 of Standard Size Notebook

Page 5 in both notebooks has the exact same dot pattern!

## 3 Setting Your Primary Notebook

- Tell your pen which notebook to use
- Ensures notes go to the right place
- Creates a seamless writing experience

## 2.5 Home

The Home screen is the main dashboard of XNote. It displays a personalized overview with quick access to your notebooks, recordings, tasks, and upcoming events.

At the top, you will see a welcome message with your name, a microphone button for starting a recording or sending a bot to a meeting, and your profile avatar to access Settings.

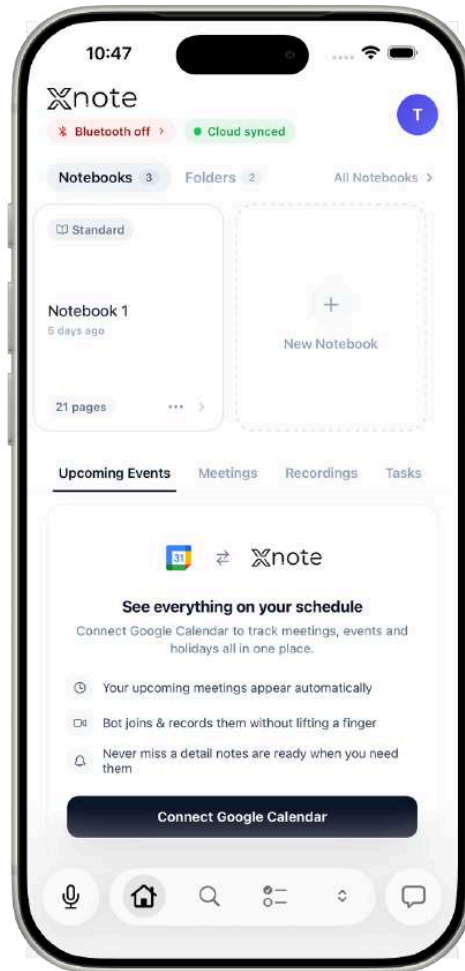

## 2.5.1 Pen Status

The Pen Status is displayed on the Home screen and shows the current connection state of your XNote Smart Pen.

**How to access:** Always visible on the Home screen.

**States:** Scanning Blue Bluetooth Text. Pen is not connected. Tap to open the scanning screen.

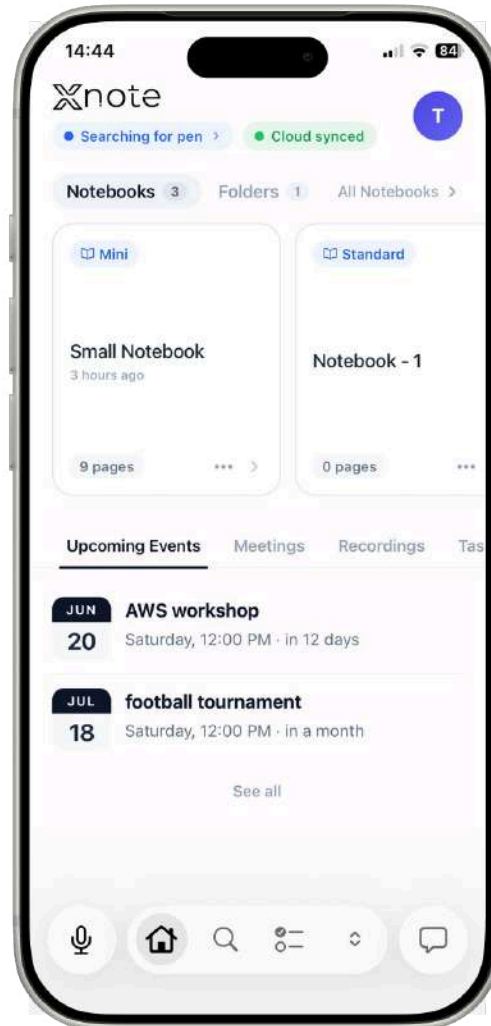

Found : Blue Bluetooth Text. Pen discovered, ready to connect.

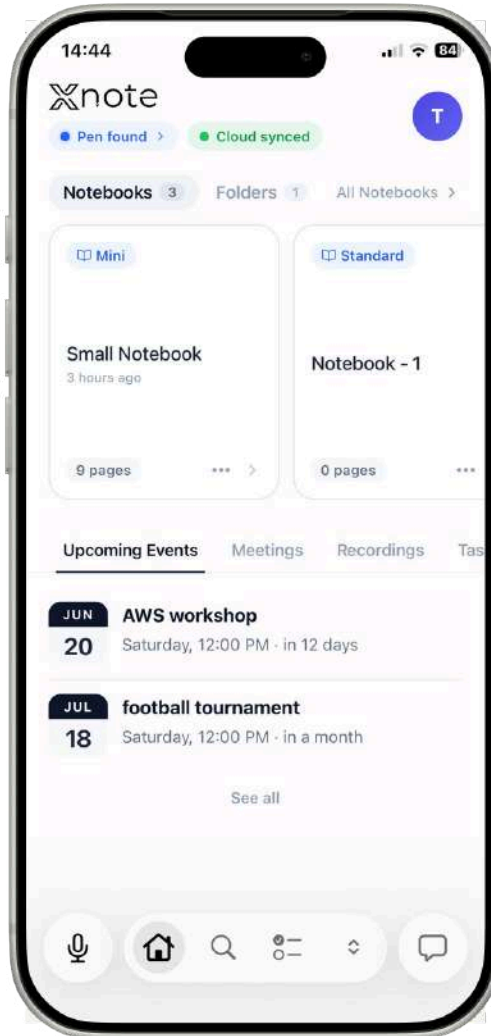

Connecting : Blue Bluetooth icon with rotating animation. Connection in progress.  
Connected with green Text

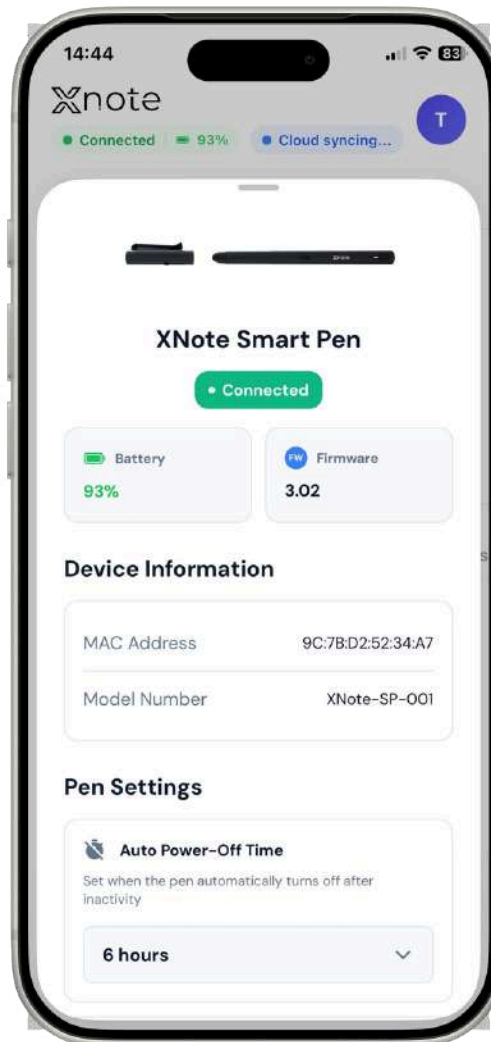

**When you tap the badge:**

- If connected: Opens Pen Settings [\(see 2.7 for full details\)](#).
- If not connected: Opens the Bluetooth scanning screen to find and pair your pen [\(see 2.3\)](#).

## Permission & Hardware Alerts:

Before scanning can start, the **permission indicator** (top-left) checks status. If something is missing, a warning appears instead of the normal status:

- **Bluetooth permission not granted:** Amber Bluetooth-off icon. Tap to grant Bluetooth permission.

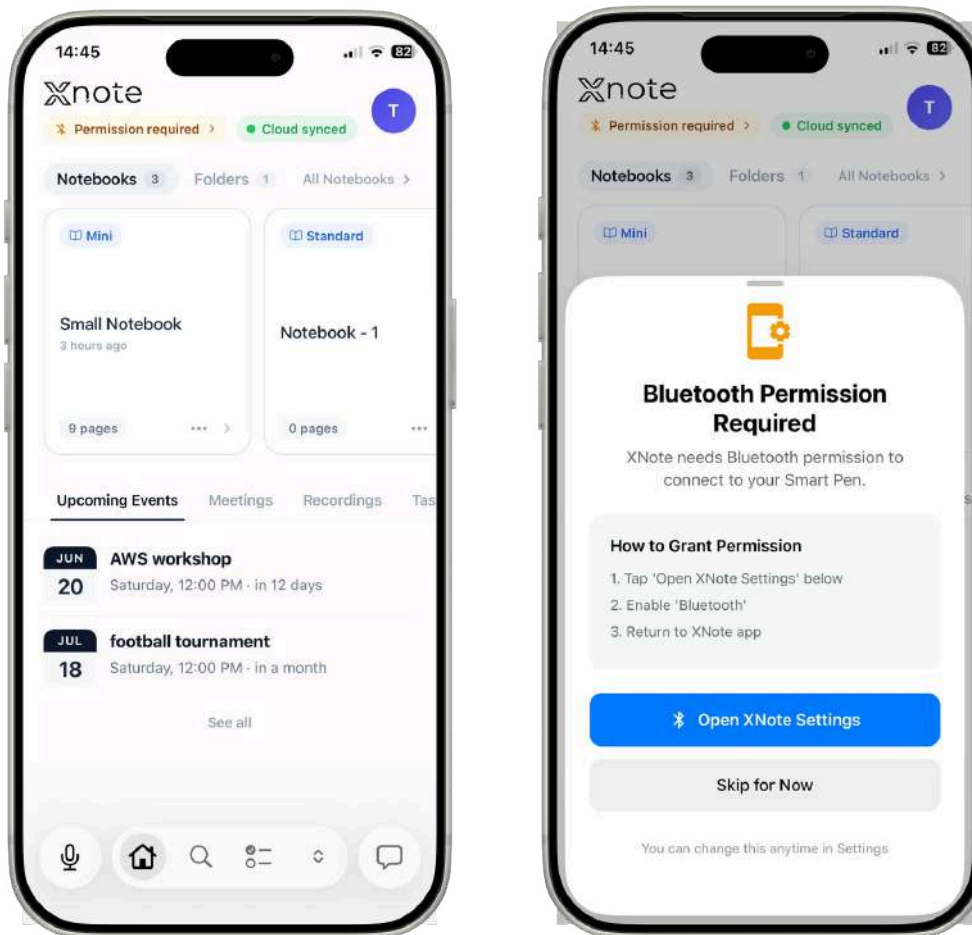

- Bluetooth is turned off : Red Bluetooth-off icon. Tap to open Bluetooth settings.

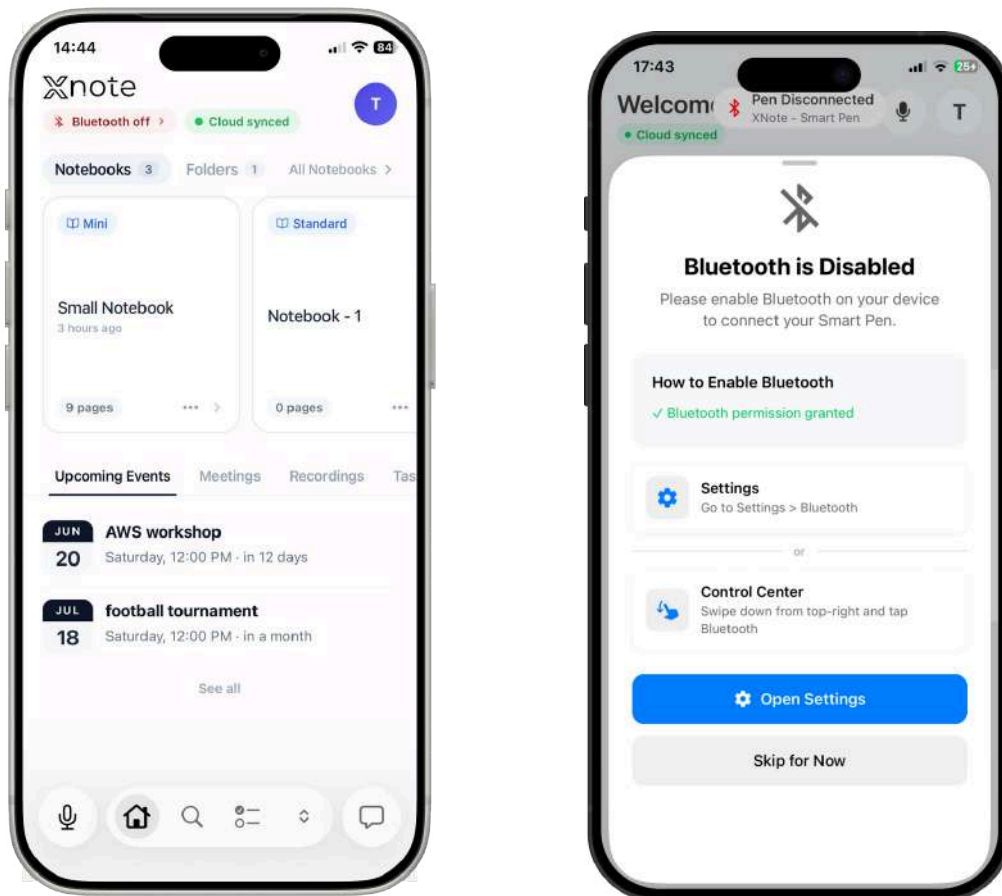

- Location permission not granted (Android only) : Amber location icon. Tap to grant Location permission.
- Location is turned off (Android only) : Red location icon. Tap to open Location settings.

These checks follow a priority order: Bluetooth permission → Bluetooth enabled → Location permission (Android) → Location enabled (Android). Only the first unresolved issue is shown at a time. Resolving it will either reveal the next issue or allow scanning to begin.

Why Location? Android requires Location permission for Bluetooth Low Energy device scanning. XNote does not track your location.

## 2.5.2 Notebooks View

Your notebooks are displayed as horizontal scrollable cards. Each card shows:

- Notebook type badge (Mini / Standard / Large)
- Primary indicator (if set as primary notebook)
- Pin indicator (if pinned)
- Notebook title
- Page count
- Last edited time

Pinned and primary notebooks appear first. Tap a notebook to open it. Tap **"+ New Notebook"** at the end of the list to create a new one ([see 2.6.2](#)). Tap **"All Notebooks"** to view all notebooks ([see 2.6.1](#)).

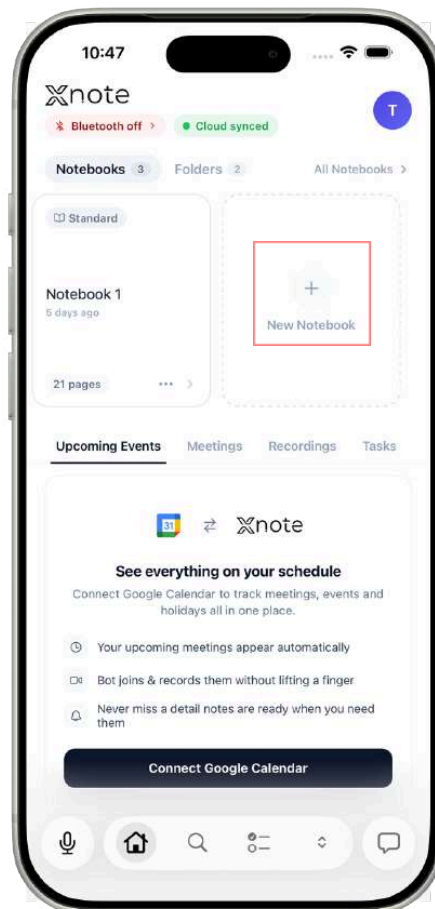

## 2.5.3 Folders View

Switch to the Folders tab using the segment control at the top of the section. Folders are displayed as horizontal scrollable cards showing:

- Folder emoji
- Folder name
- Page count

Tap a folder to view its pages ([see 2.14.3](#)). Tap **"+ Create Folder"** to add a new one ([see 2.14.1](#)). Tap **"See All"** to view all folders ([see 2.14.2](#)).

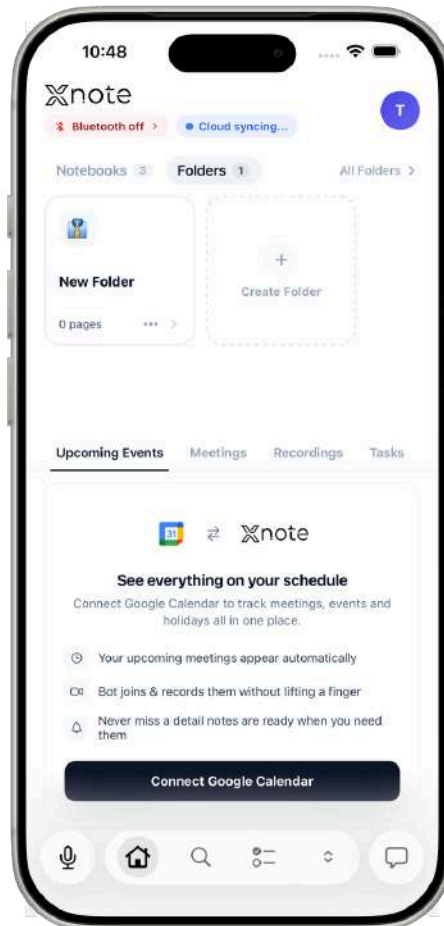

## 2.5.4 Activity Tabs

The Activity Tabs provide a centralized view of the user's events, meetings, recordings, and tasks, organized into four distinct sections for quick access and management.

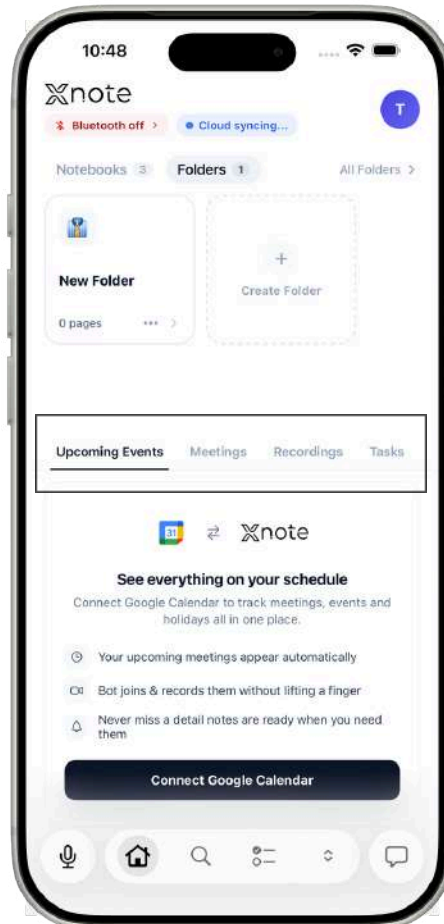

### 2.5.4.1 Upcoming Events

This tab displays the user's nearest upcoming events. On first use, the system prompts the user to connect their calendar. If the user does not connect a calendar, only locally derived events—extracted from the user's notes—are shown. Once the user connects their Google account, the tab displays the 10 nearest upcoming events by date, combining both Google Calendar events and locally derived events.

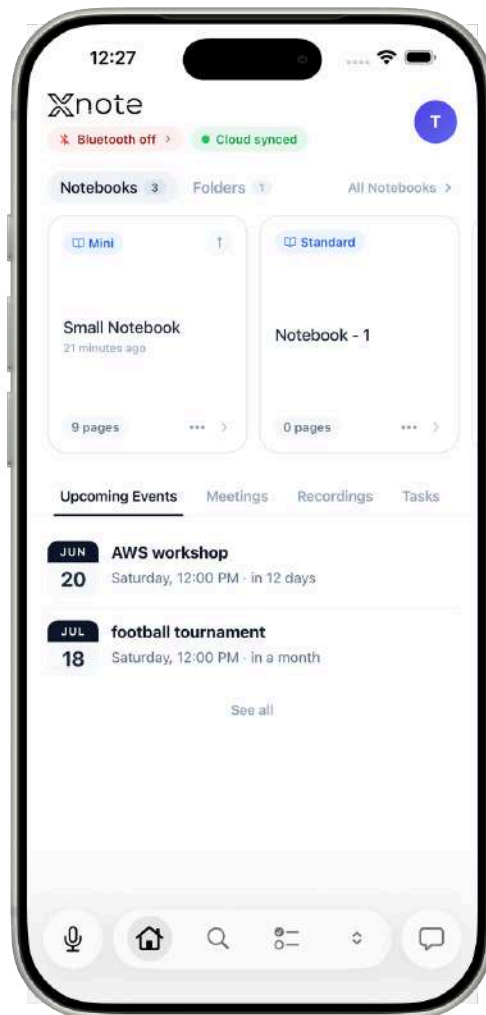

## 2.5.4.2 Meetings

This tab focuses on the user's scheduled meetings. As an initial step, the system requests the user to connect their Google account. Once connected, the Xnote bot automatically joins the meetings on the user's calendar and generates recordings of them. These meeting recordings can then be viewed under the Meetings tab.

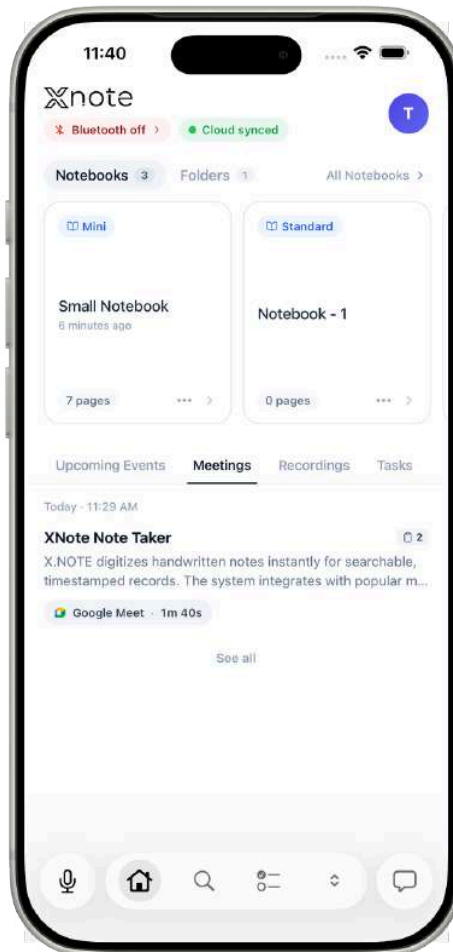

### 2.5.4.3 Recordings

This tab contains the manual recordings the user has captured directly on their phone. Users can view and access all of their locally recorded audio in one place.

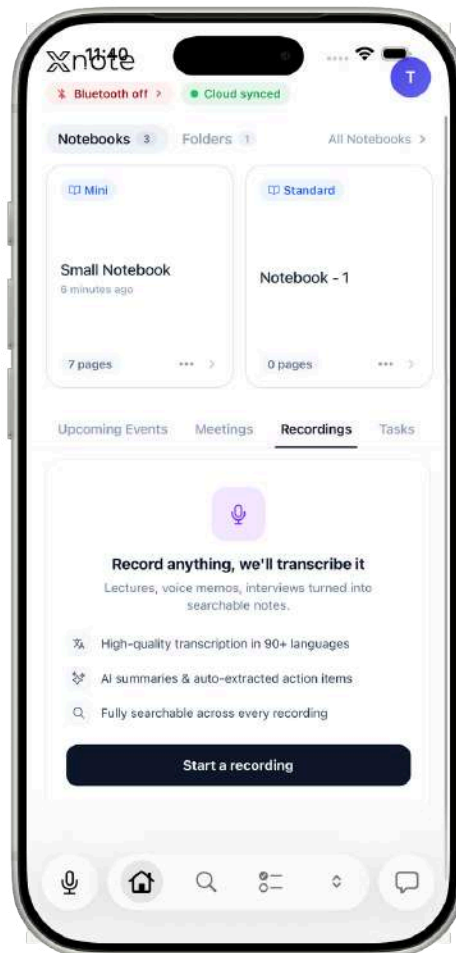

## 2.5.4.4 Tasks

This tab consolidates all tasks from multiple sources. It includes tasks extracted from the user's notes, as well as tasks generated from meetings and manual recordings. All tasks are organized and displayed under their respective headings for easy tracking.

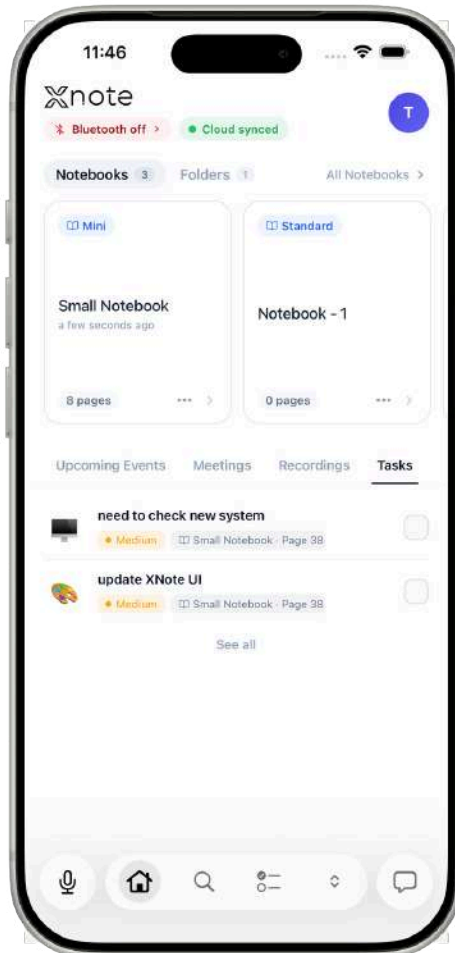

## 2.5.5 Task Screen

The **"Tasks"** section shows your 5 most recent incomplete tasks as a horizontal scroll carousel with pagination dots. A blue badge in the header shows the total task count.

Each card displays:

- Task emoji or source icon (microphone for audio tasks, checkbox for page tasks)
- Priority color bar on the left (red = high, orange = medium, green = low)
- Task title (max 2 lines)
- Source badge (e.g., **"Meeting"** with microphone icon for audio-sourced tasks)
- Checkbox to mark as complete

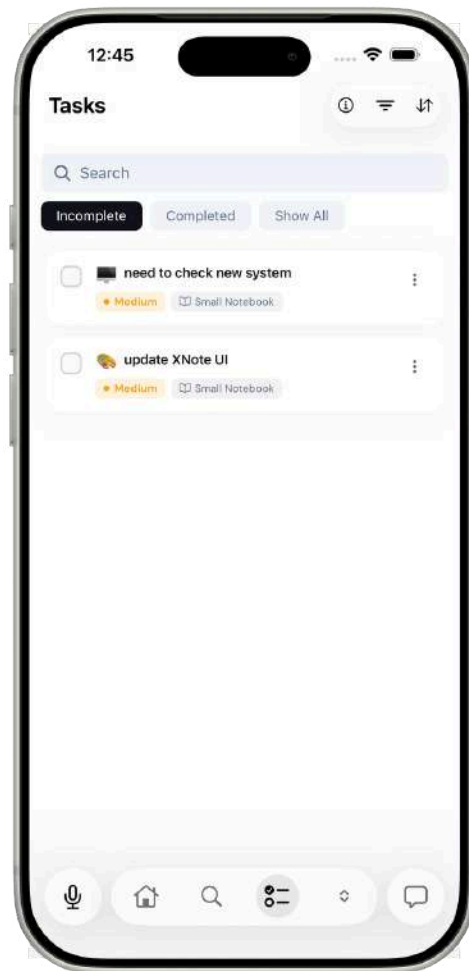
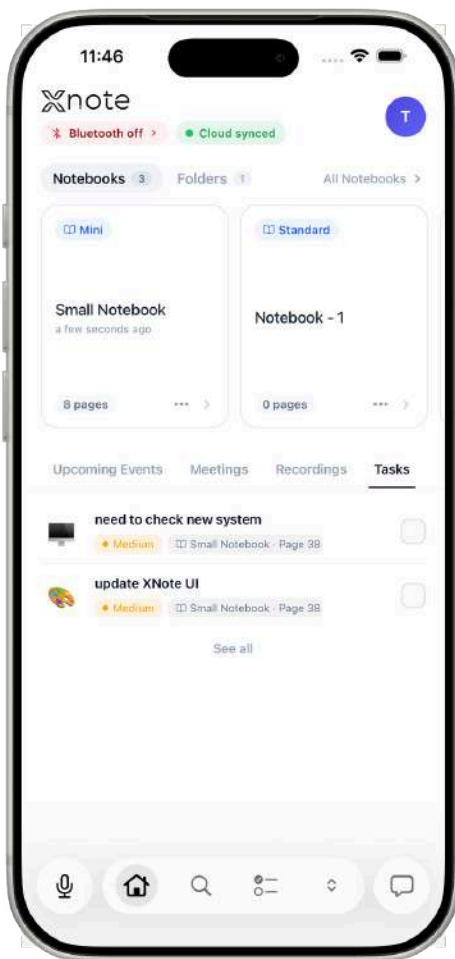

## 2.5.6 Upcoming Events

The Upcoming Events section shows your next 5 calendar events that have meeting links. Each card displays:

- Date and month
- Event title
- Meeting provider logo (Zoom, Google Meet, Teams, etc.)
- Event time
- Auto-record toggle to send a bot to the meeting

If Google Calendar is not connected, a **"Connect Calendar"** prompt will appear instead.

Tap an event to view its details [\(see 2.12.3\)](#).

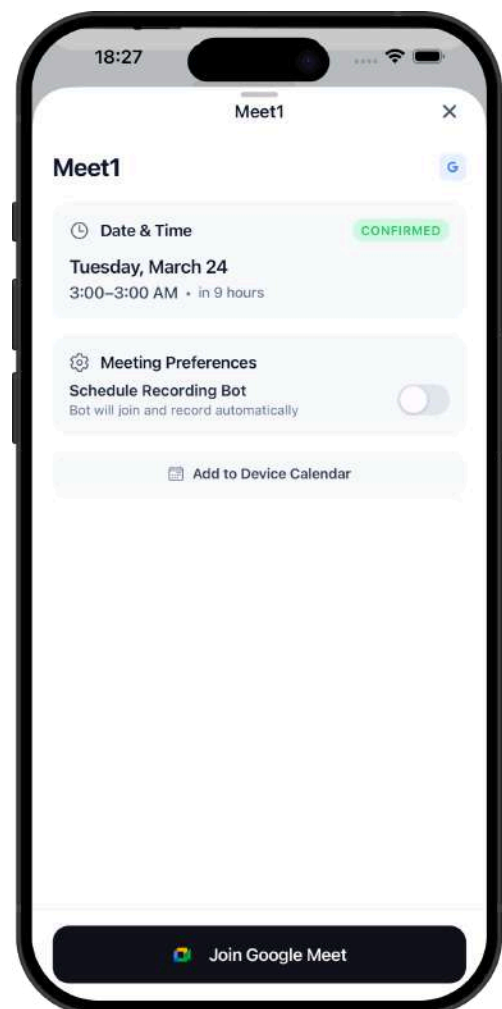
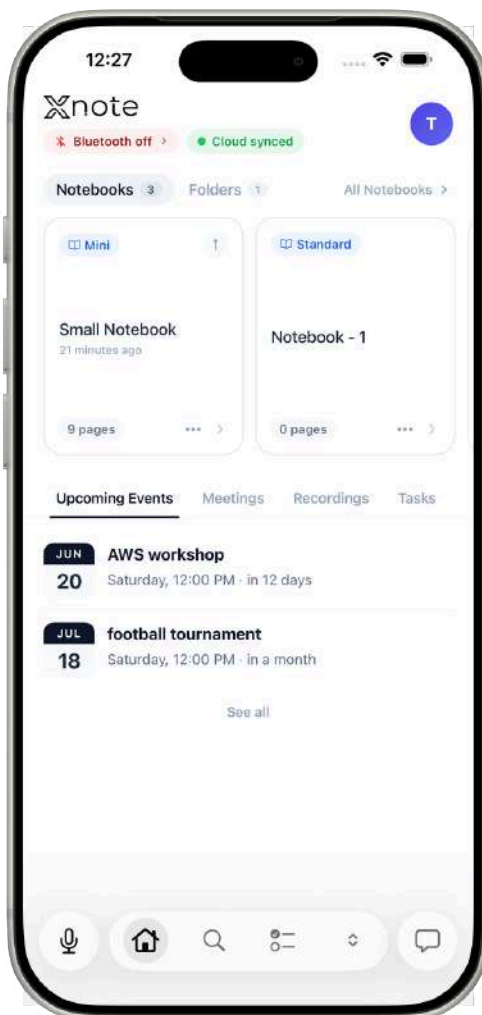

Tap the info icon in the section header to open the Meeting Bot Guide a help page explaining event formats, valid meeting link examples, timing options, and frequently asked questions about the recording bot.

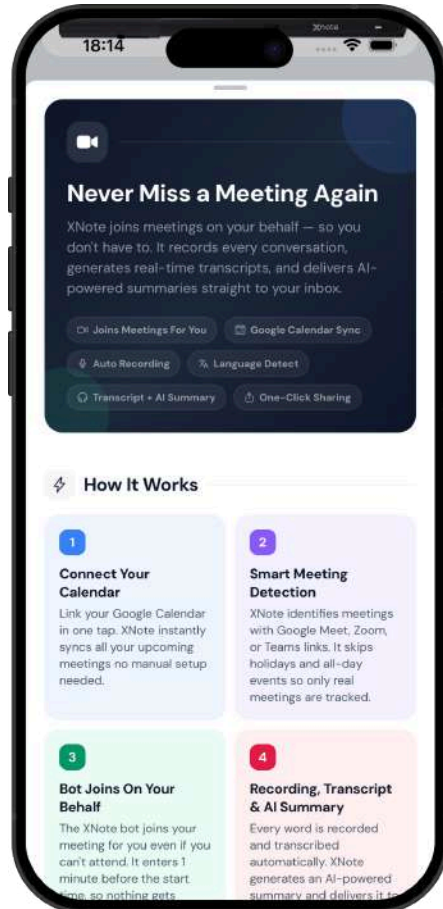

## 2.6 Notebooks & Pages

Notebooks are the core of XNote. Each notebook contains pages of your handwritten notes, synced from your XNote Pen.

### 2.6.1 View Notebooks

All your notebooks are listed on the All Notebooks screen. Each notebook shows:

- Notebook title
- Type badge (Mini / Standard / Large)
- Primary indicator (if applicable)
- Pin indicator (if pinned)
- Page count
- Last edited time

You can sort notebooks by created date, title, page count, or type. Use the search bar to find a notebook by name. Tap a notebook to open it.

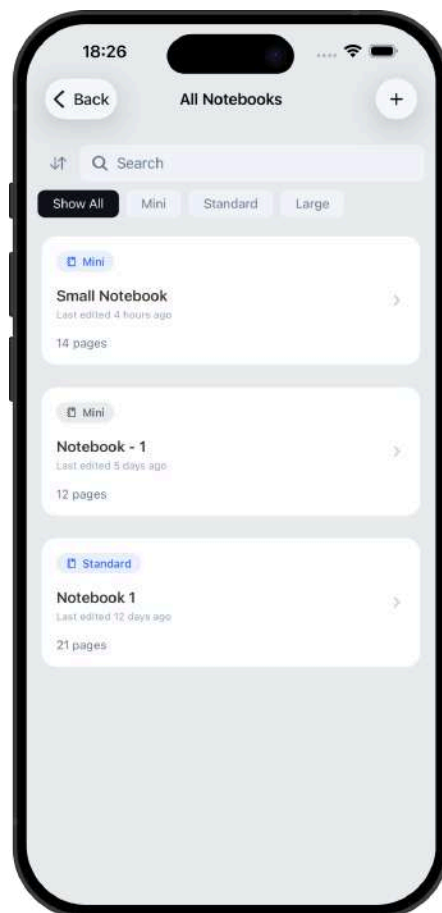

## 2.6.2 Create a Notebook

There are three ways a notebook can be created:

### Manual Creation:

1. Tap the "+" button on the All Notebooks screen or "+ New Notebook" on the Home screen.

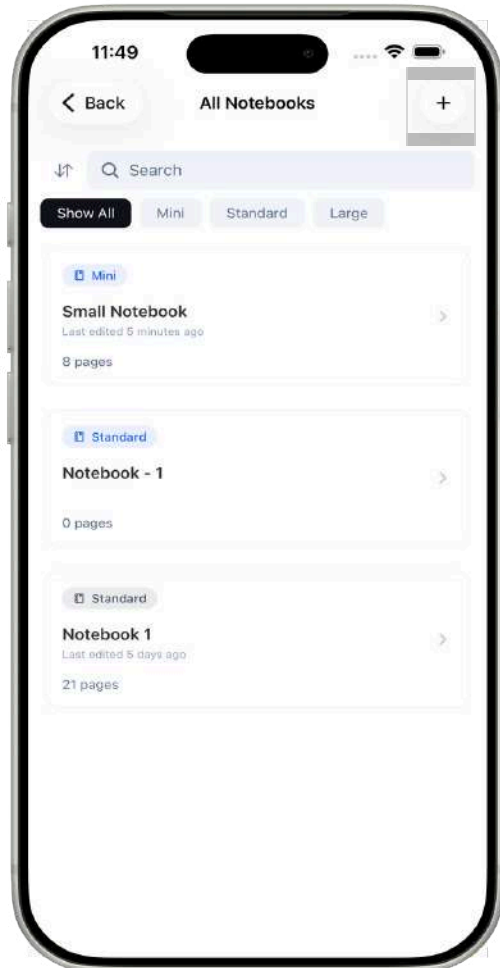
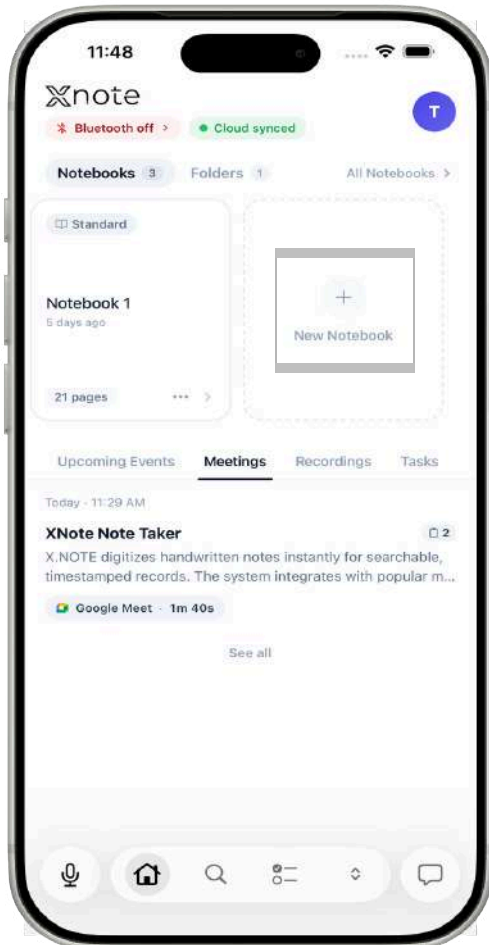

2. A bottom sheet will appear. Select the notebook size: Mini, Standard, or Large.

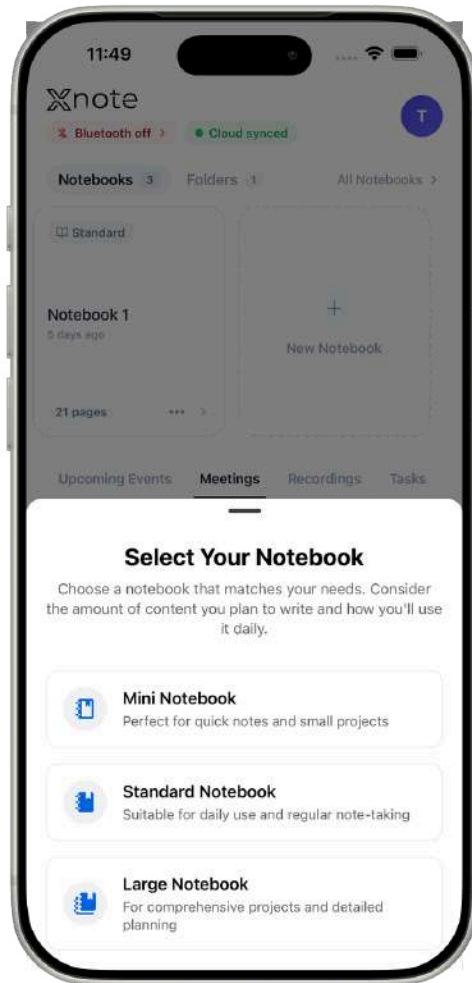

3. The notebook is created automatically.

### **Automatic Creation (Pen Writing):**

When you write with your XNote Pen on a notebook size that doesn't have any notebooks yet, XNote will automatically create a new notebook and set it as your primary for that size. This happens silently you can continue writing without interruption.

From Notebook Selection:

Wherever XNote asks you to select a notebook such as linking pages to an audio recording, or choosing a target notebook during offline sync a **"Create New"** button is available at the bottom of the notebook list. This lets you create a new notebook without leaving the current flow. During offline sync, if no notebook of the matching size exists at all, XNote will prompt you with a dialog: **"No [size] notebook found. Create one?"** before proceeding. For more on syncing, [\(see 2.16\)](#).

In all cases, if the notebook is the first of its size, it will automatically be set as your primary notebook [\(see 2.4\)](#).

## **2.6.3 Set Primary Notebook**

You can change which notebook is set as primary for each size at any time. Tap the three-dot menu on any notebook card and select **"Set as Primary"**, or go to Settings → Primary Notebooks.

For a full explanation of how primary notebooks work and why they matter, [see 2.4](#) Set Your Primary Notebook.

## **2.6.4 Pin a Notebook**

Pinning moves a notebook to the top of the list on the Home screen. Only one notebook can be pinned at a time.

1. Tap the three-dot menu on a notebook card.

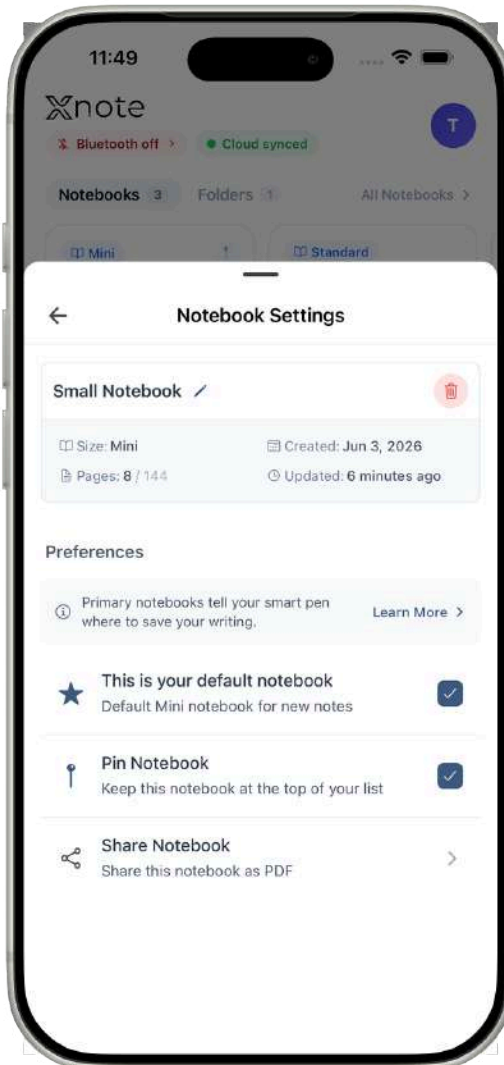

2. Toggle "Pin Notebook" on.

A pin icon will appear on the notebook card. To unpin, toggle it off from the same menu.

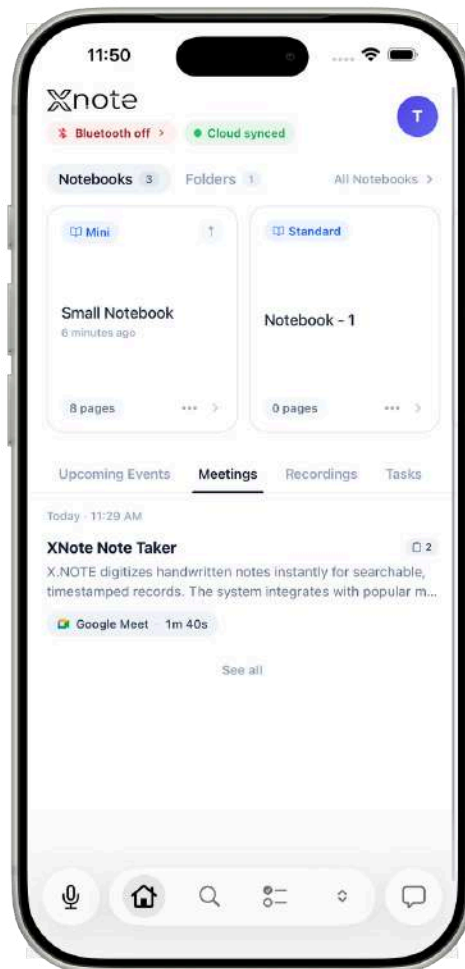

## 2.6.5 Browse Pages

Tap a notebook to view its pages in a grid layout. Each page shows:

- Page thumbnail (handwriting preview)
- Page number badge

You can sort pages by page number or last edited date. Long-press a page to enter selection mode for bulk export.

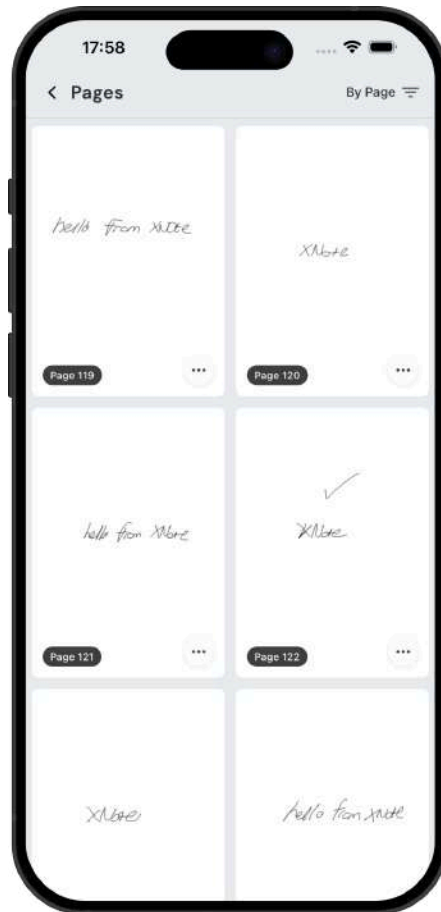

## 2.6.6 View Page Details (Canvas & Text)

Tap a page to open the detail view. The layout adapts to your device:

- On iPhone: Full-screen canvas with a floating bottom navigation bar.
- On tablet: Full-screen canvas with a floating top bar and a collapsible right sidebar for controls.
- On iPad: Split-view layout where the digital text panel and AI Chat can open as side panels alongside the canvas.

### Canvas View:

The canvas displays your original handwriting strokes. You can:

- Swipe left or right to navigate between pages.
- Draw on the canvas using your XNote Smart Pen.
- Pinch to zoom in and out on your handwriting.



## Notebook Background:

Tap the background toggle button (four horizontal lines icon) to show or hide the notebook background lines. This button is only visible when the digital text panel is closed. The background setting also affects exports [\(see 2.15.5\)](#).



### Color Picker:

If the color picker is enabled in Pen Settings ([see 2.7.1](#)), a color swatch button appears in the action buttons. Tap it to open the color picker:

- On iOS: A native color picker appears.
- On Android: A modal opens with a hue/saturation panel, hue slider, and preview. Tap **"Done"** to apply.

The selected color is applied to all new strokes drawn on the canvas.

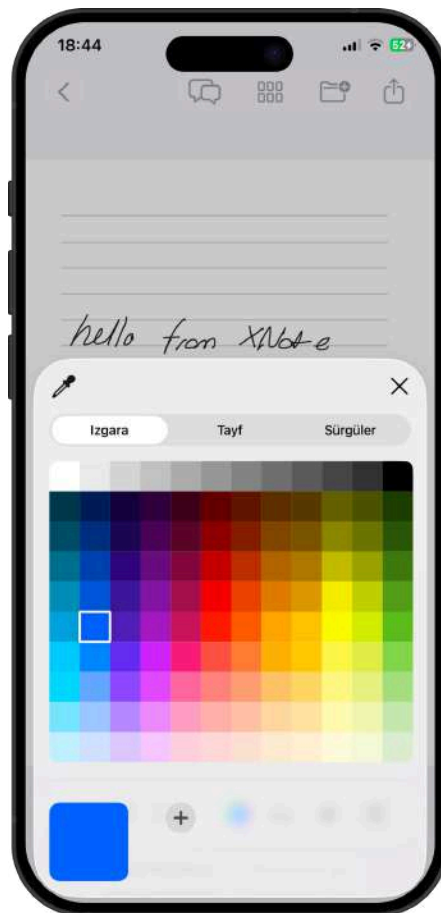

## Digital Text View:

Tap the text toggle button ("**Aa**" icon) to open the digital text panel showing the OCR-extracted text from your handwriting.

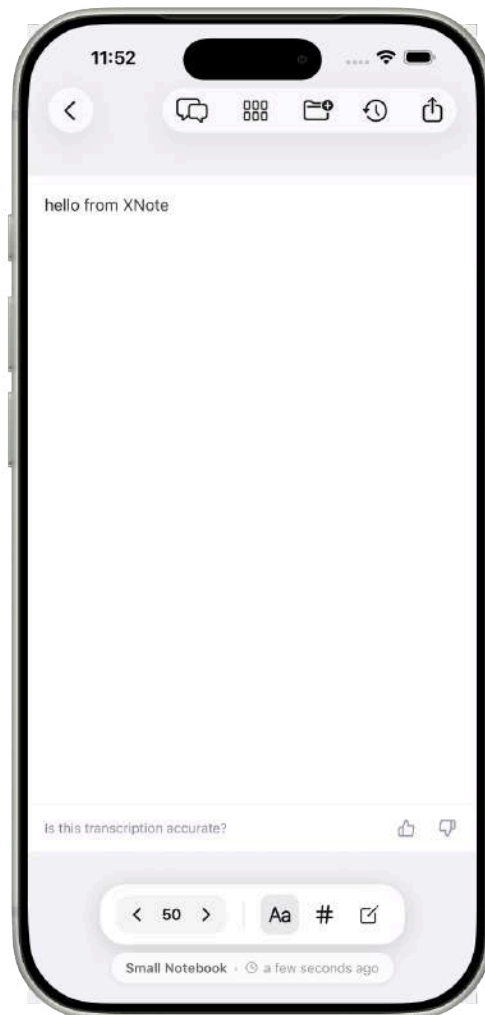

- On iPhone: The text overlays the canvas as a full-screen card.
  - On iPad: The text opens as a right sidebar (50% of screen width) alongside the canvas.
- The digital text panel shows:
- The extracted text content, which you can select and copy.
  - Font size controls (iPad only): Use the +/- buttons to adjust text size between 14px and 24px.
  - Mermaid diagram rendering if the page contains diagrams.
  - An "**Edited by user**" indicator (bottom-right, gray italic text) if the text has been manually edited.

- Loading state: **"Loading page content..."** spinner while fetching.
- Empty state: **"No text found on this page"** if OCR has not extracted any text.

### Page Navigation:

Navigate between pages using any of these methods:

- Previous/Next arrows: Tap the arrow buttons in the navigation bar. The previous arrow is disabled on page 1.
- Swipe gesture: Swipe left or right on the canvas to move between pages.
- Jump to page: Tap the page number in the navigation bar to open a modal. Enter a page number and confirm. Only pages that have been written on are available.



### Processing Status:

Below the navigation bar, a status indicator shows the current processing state of the page:

- **"Uploading page..."** : Strokes are being uploaded to the server.



- "Waiting for processing..." : Upload complete, waiting for OCR.



- "Analyzing page..." : OCR is extracting text from your handwriting.



- "Extracting tasks & events..." : AI is identifying action items and calendar events.



- **"Last modified: X minutes ago"** : Shows when processing is complete.

A rotating sync icon (amber color) animates during processing.

Toolbar Actions:

The following action buttons are available in the toolbar (bottom bar on iPhone, side bar on tablet/iPad):

- Digital Text (Aa / text icon) : Toggle the OCR text panel on/off.
- Tags (# hashtag icon) : Open the Page Tag Management screen ([see 2.14.6](#)).
- Edit Text (Pencil icon) : Open the text editor. Only visible when digital text panel is open.
- Background (Lines icon) : Toggle notebook background on/off. Only visible when digital text panel is closed.
- Color Picker (Color swatch) : Open the color picker to change pen stroke color.
- Folder (Folder icon) : Add this page to a folder ([see 2.14.4](#)).
- Export (Upload icon) : Open the export screen for this page ([see 2.15.5](#)).
- Chat (Chat bubble) : Open AI Chat with this page mentioned ([see 2.9.2](#)). On iPad, opens as a side panel.
- Pages Grid (Grid icon) : Return to the page grid view for this notebook.

Page Info:

- The notebook name is shown below the navigation bar (gray text).
- The current page number is displayed in the center of the navigation bar.

## 2.6.7 Edit Page Content

Edit Handwriting (Canvas):

You can draw on the canvas using your XNote Smart Pen. Select a pen color from the color picker in the toolbar ([see 2.6.6](#)). Strokes are saved automatically.

### Edit Text (OCR):

1. Open the digital text panel by tapping the text toggle button.
2. Tap the Edit button (pencil icon) in the toolbar. This opens a full-screen text editor.
3. Modify the extracted text.
4. Tap **"Done"** to save your changes, or **"Cancel"** to discard.

Edited pages will show an **"Edited by user"** indicator at the bottom-right of the digital text panel. This label persists to indicate that the text has been manually modified from the original OCR output.

Note: Editing the text does not change your handwriting on the canvas it only modifies the digital text representation used for search, export, and AI features.

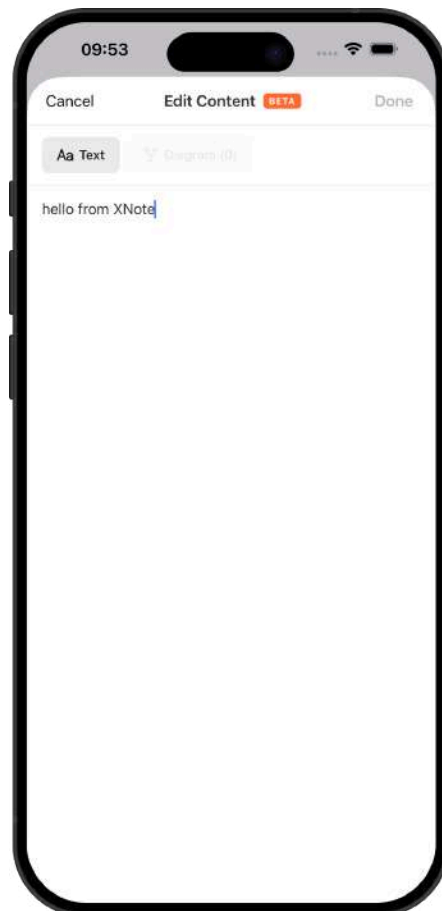

## 2.6.8 Delete a Notebook

Delete a Notebook:

1. Tap the three-dot menu on a notebook card.
2. Tap the trash icon.
3. Confirm deletion in the dialog.

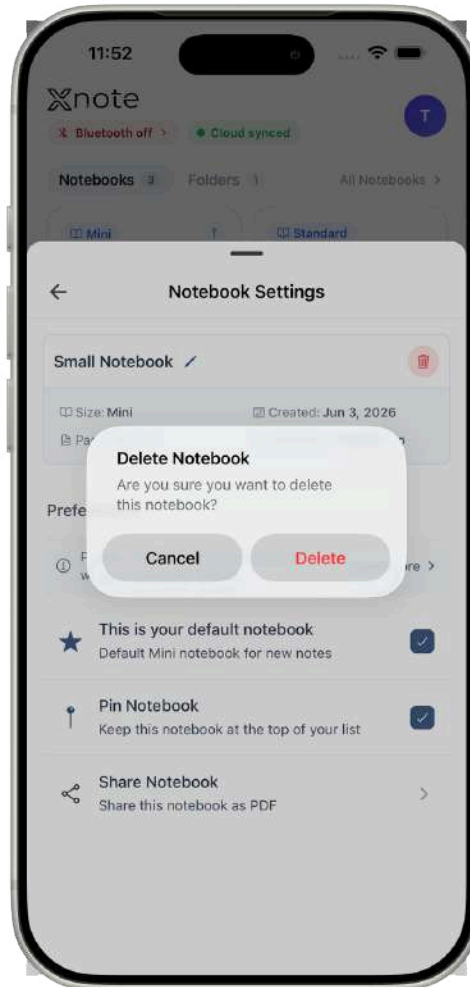

Deleted notebooks are kept for 30 days and can be recovered from Settings -> Deleted Notebooks.

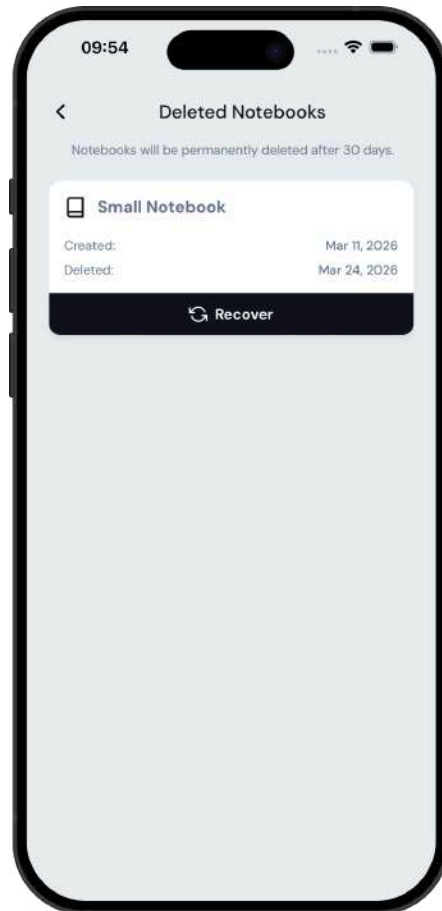

If you delete a primary notebook, XNote will automatically assign another notebook of the same size as primary.

Delete a Page:

Pages are tied to their notebook. Individual pages cannot be deleted separately, but you can remove pages from folders using the page's three-dot menu.

## 2.7 Pen Settings & Factory Reset

Manage your XNote Smart Pen's configuration and perform advanced operations.

How to access: You can reach Pen Settings in two ways:

- From the Home screen: Tap the Pen Status Badge when your pen is connected (the blue settings gear icon). [\(See 2.5.1\)](#).
- From Settings: Go to Settings -> Pen Settings.

Note: Pen Settings are only available when the pen is connected via Bluetooth.

### 2.7.1 Pen Settings

The Pen Settings screen allows you to configure the following:

- Auto Power-Off : Set the idle time before pen turns off (1-10 hours).
- Pen Sound : Toggle the pen's sound on or off.
- Color Picker : Show or hide the color picker in the writing interface.

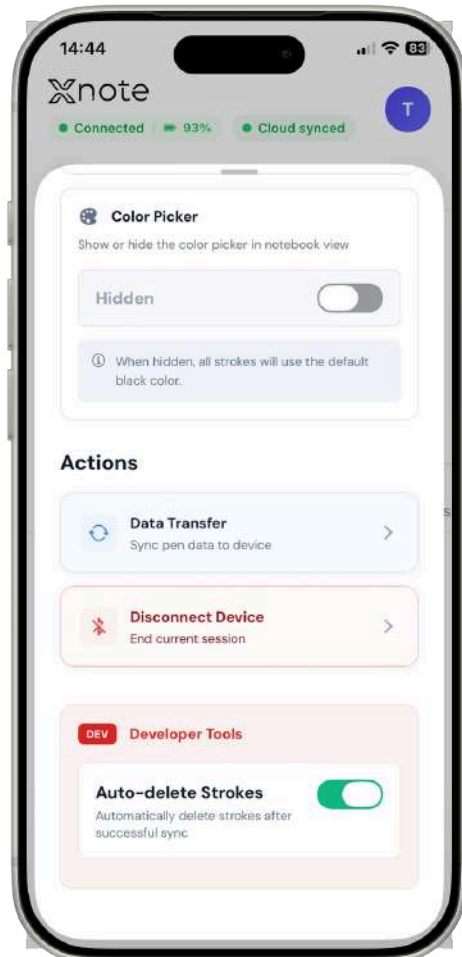
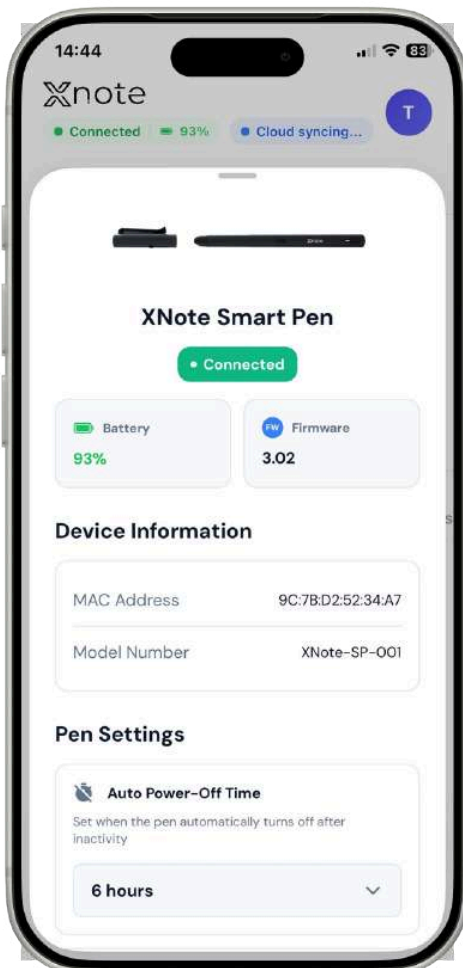

- Mirror Writing : For left-handed users who write in reverse (see details below).
- Device Info : View MAC address, model number, battery level, and firmware version.
- Disconnect Device : Disconnect the pen from the app.

### Mirror Writing

This setting is designed for left-handed users who naturally write in reverse (from right to left), producing mirror-image handwriting. When enabled, the canvas is flipped horizontally so you can write from right to left naturally, and XNote's OCR engine will correctly interpret your reversed handwriting.

When you toggle Mirror Writing:

- Enabling: A confirmation dialog appears explaining that the canvas will be flipped horizontally. If you write normally (left to right), do NOT enable this it will cause incorrect text recognition results.
- Disabling: A confirmation dialog explains that the canvas will return to normal orientation.

Important:

- Mirror Writing is independent from the Handedness setting ([see 2.2 Step 3](#)). Being left-handed does not automatically mean you use mirror writing. Most left-handed users write normally and do not need this setting.
- Only enable this if you actually write in reverse (mirror image). Enabling it with normal handwriting will produce incorrect OCR text.
- This setting affects how your handwriting is displayed on the canvas and how it is processed for text recognition. It does not modify your saved stroke data.

## 2.7.2 Factory Reset

Factory Reset completely resets your XNote Smart Pen to its original factory settings. This erases all pen data and settings permanently. Your account, notebooks, and synced notes in the app are not affected.

Step 1 : Open Service Menu

Go to Pen Settings (see above). Tap the MAC address field 5 times to unlock the hidden Service Menu.

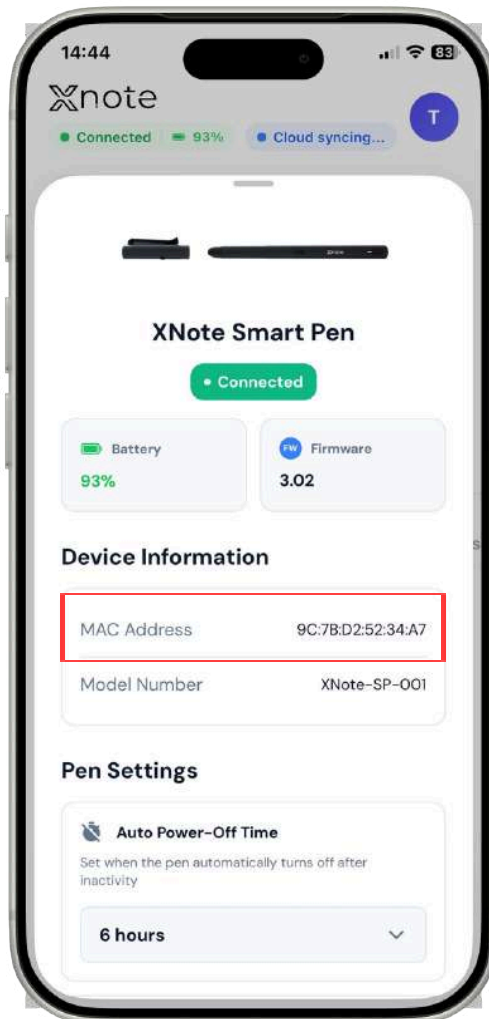

Step 2 : Tap Factory Reset

In the Service Menu, tap the **"Factory Reset"** button. This button is only available when the pen is connected.

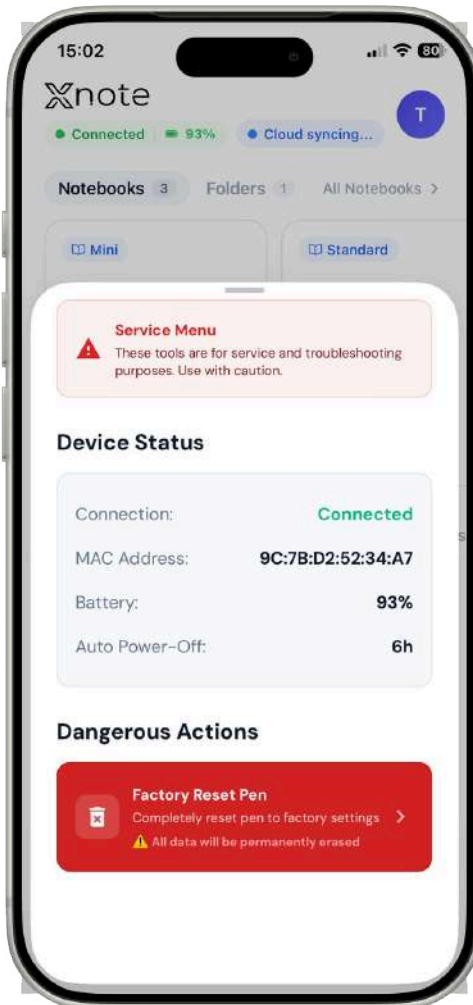

Step 3 : First Confirmation

A warning dialog will appear:

**"This will completely reset your pen to factory settings. All pen data and settings will be lost. This action cannot be undone."**

Tap **"Factory Reset"** to proceed.

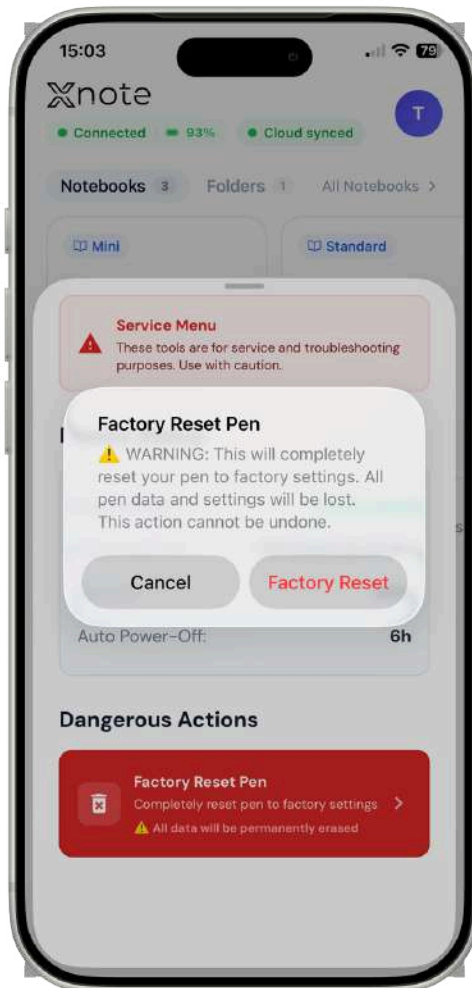

Step 4 : Second Confirmation

A second dialog will ask:

**"Are you absolutely sure? This will erase all pen data permanently."**

Tap **"Reset Now"** to confirm.

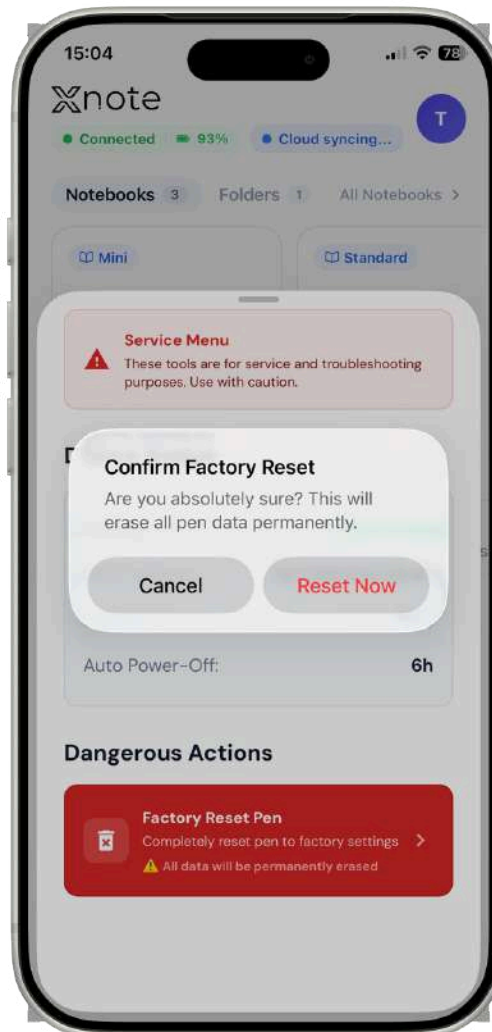

## Step 5 : Reset Complete

Once the reset is finished, a success message will appear. The pen will be disconnected from the app and returned to factory state. You can re-pair it via Bluetooth ([see 2.3](#)).

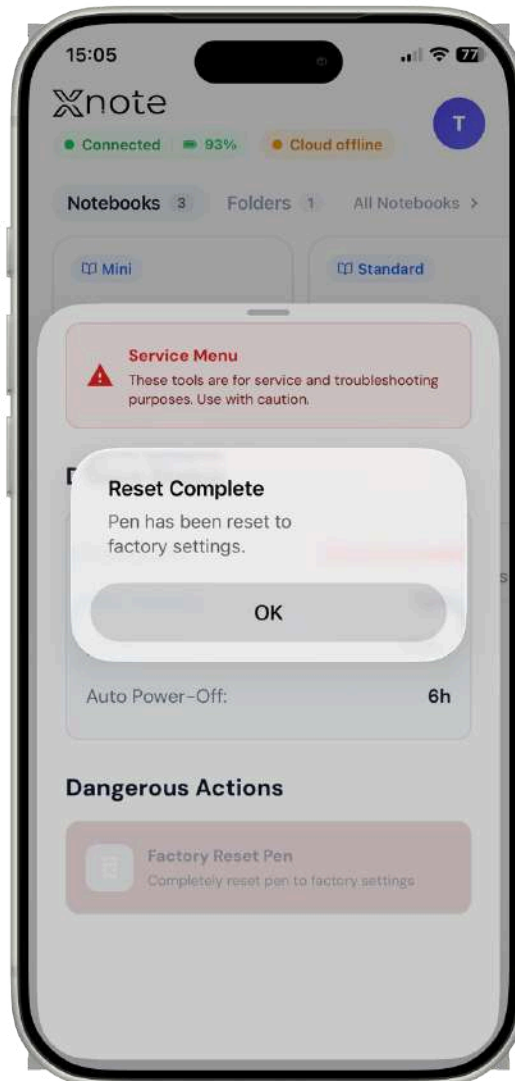

## 2.8 Audio Sessions

In XNote, audio sessions are divided into two types: **Meetings** and **Manual Recordings**.

### Accessing Meetings

You can reach the Meetings screen in two ways:

1. **From the Activity tab** Tap "See All" in the Activity section to open the full list, then navigate to your meetings.
2. **From the Tabs bar** Select "Meetings" directly from the tabs to go straight to the Meetings screen.

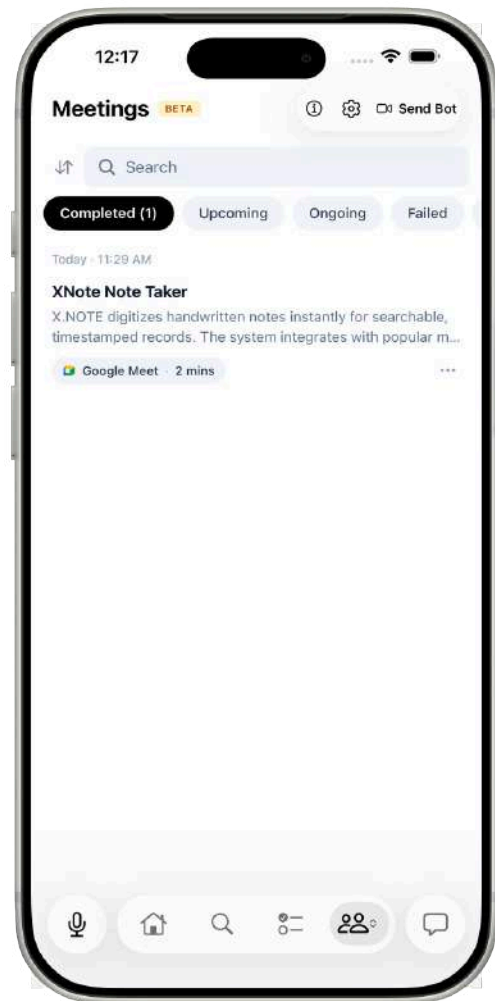
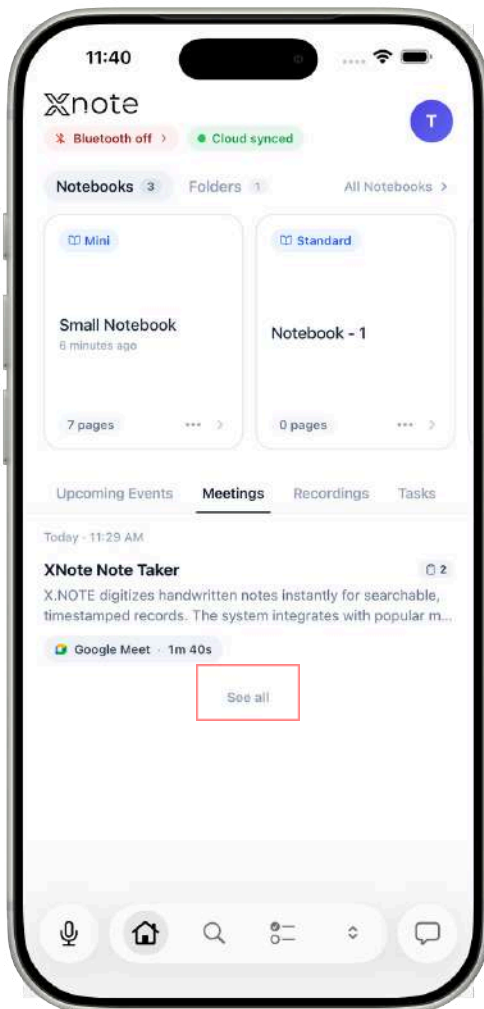

## 2.8.1 Manual Recording

Tap the microphone button in the top-right corner of the Home screen and select **"Manual Recording"**.

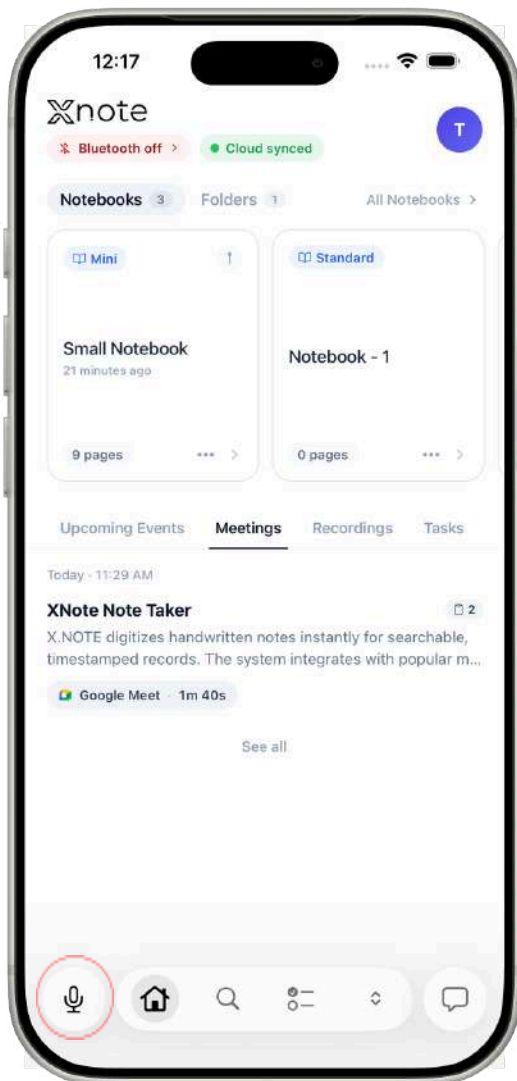

During recording, a red status bar appears showing:

- A pulsing red dot
- Recording duration (MM:SS)
- Stop button

Tap Stop to end the recording. The audio file will be automatically uploaded. There is no pause/resume : only start and stop.

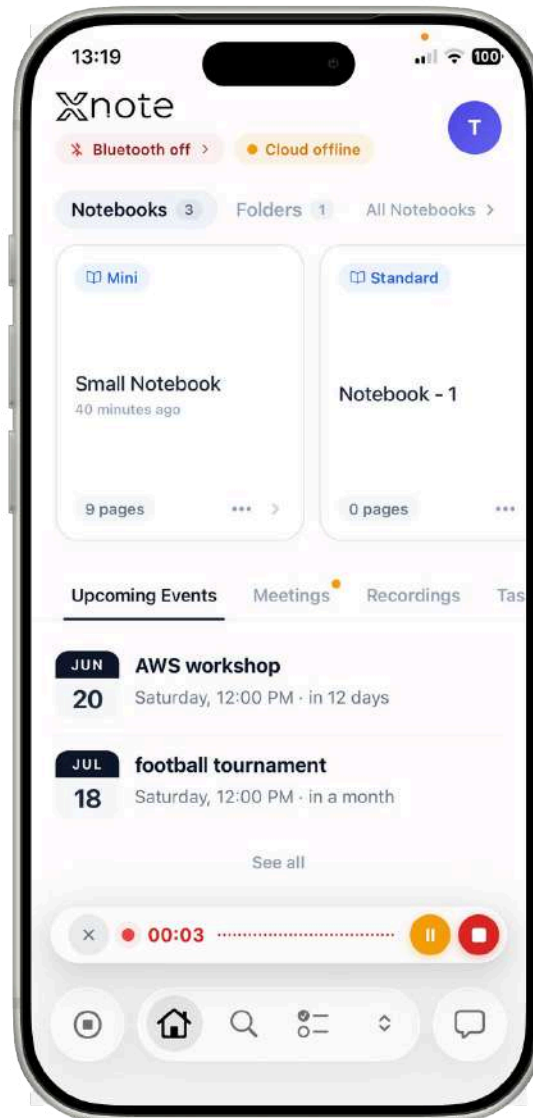

Afterwards, if you want to view your recordings, you can go to the Recordings page either by tapping "See All" in the Recordings activity tab or by selecting "Recordings" from the tabs.

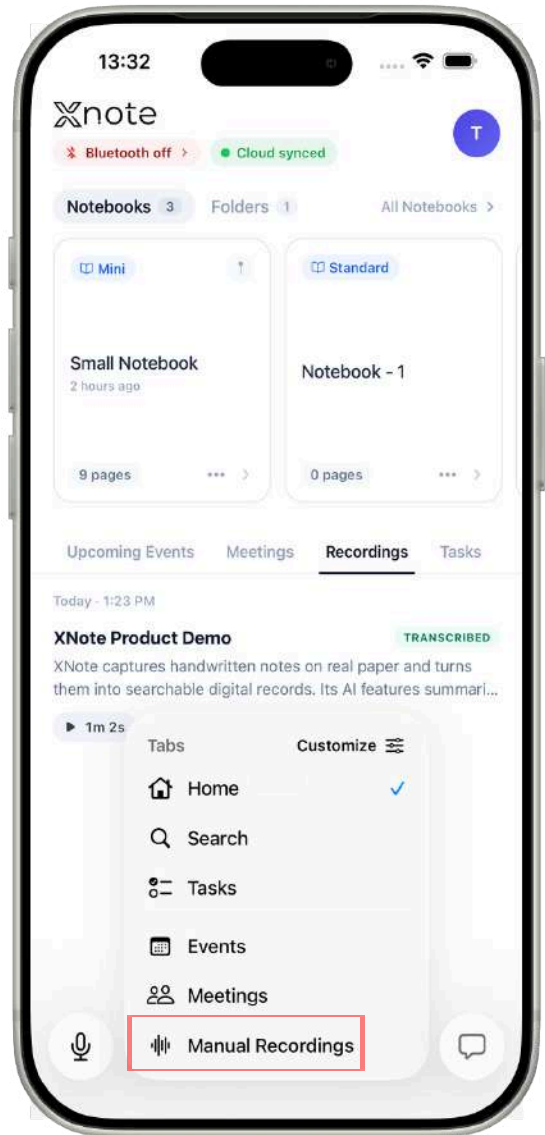
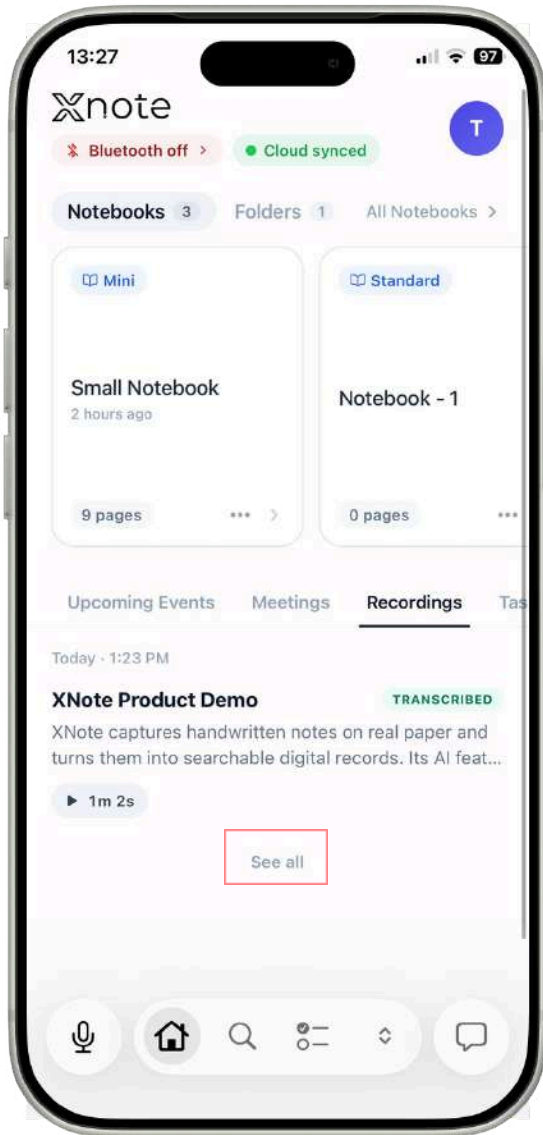

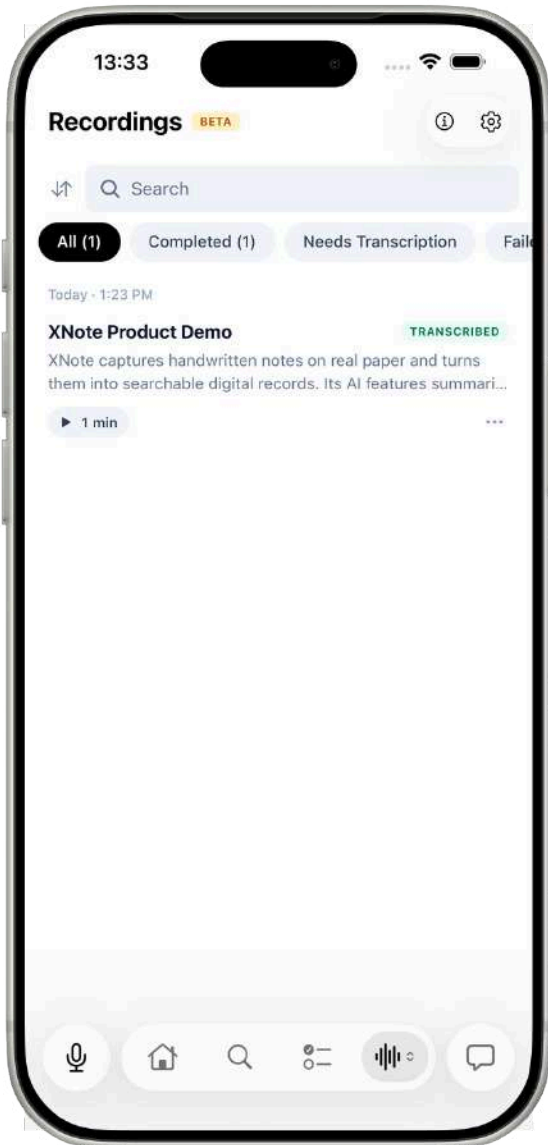

## 2.8.2 Meeting Bot (Send Bot to Meeting)

Send an AI bot to record and transcribe your online meetings.

Supported platforms: Zoom, Google Meet.

To send a bot manually:

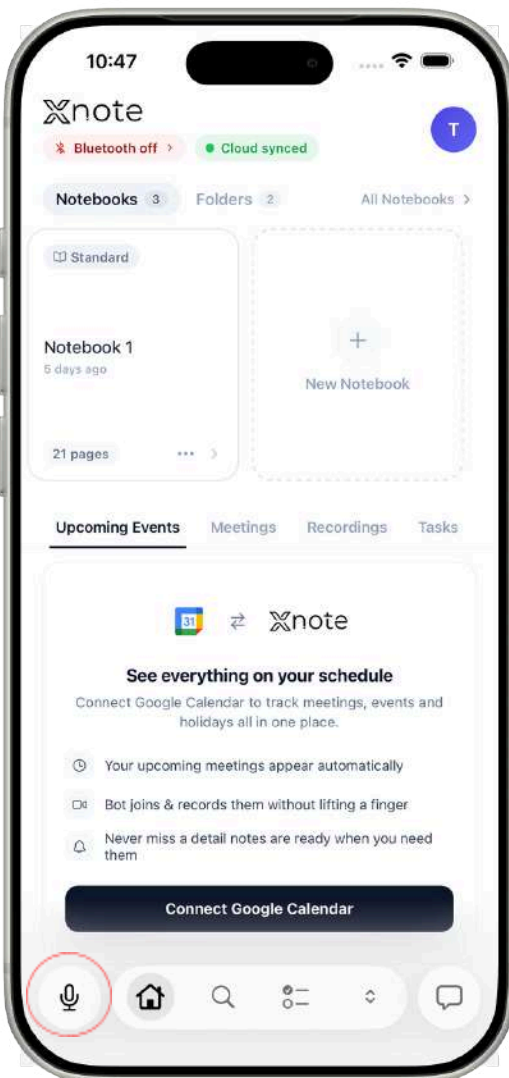

1. Tap the microphone button on the Home screen.

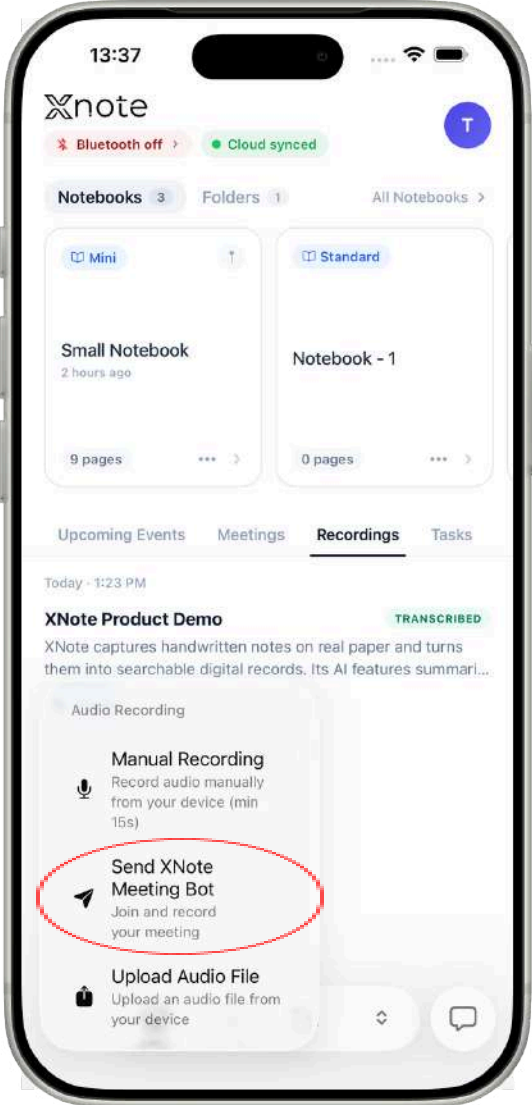

2. Select **"Send XNote Meeting Bot"**.

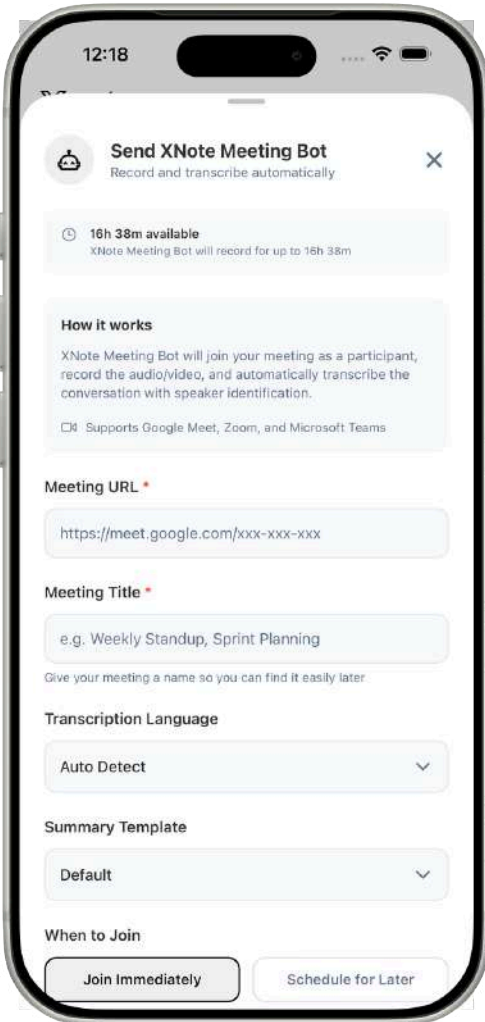

3. Enter the meeting link. XNote auto-detects the platform (Google Meet, Zoom, or Teams) and shows the provider logo.

4. Optionally set:

- Transcription language (auto-detect or select from 35+ languages)
- Schedule type: Immediate or Scheduled (with date/time picker)
- Duration: 15, 30, 45, or 60 minutes (filtered by your remaining quota)

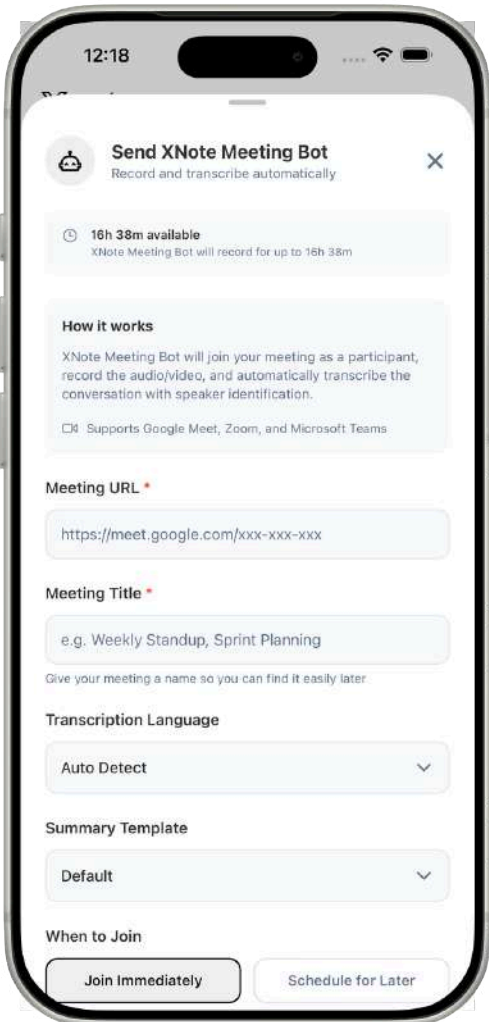

5. Tap **"Send Bot"**.

Your remaining audio minutes are shown in the modal. If your quota is depleted, you will be prompted to upgrade.

To schedule a bot for a calendar event:

Toggle the auto-record switch on any upcoming event in the Home screen or Events tab ([see 2.12.3](#)). You can also enable auto-record globally for all future meetings in Calendar Settings ([see 2.12.4](#)).

The bot status updates in real-time: Bot Ready -> Joining-> Waiting for Host -> Recording. If the bot fails to join or is not admitted, a failure status with an error message will be shown.

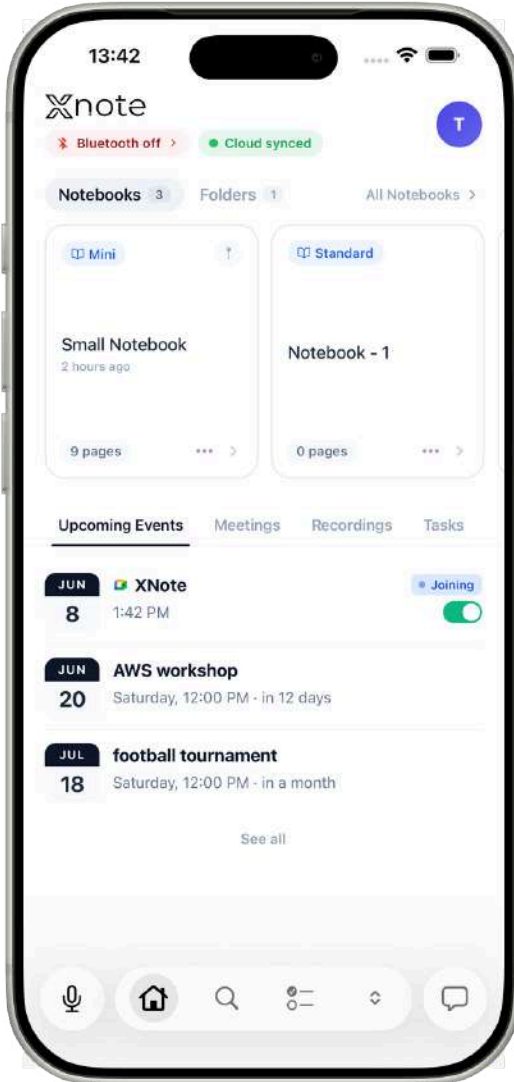
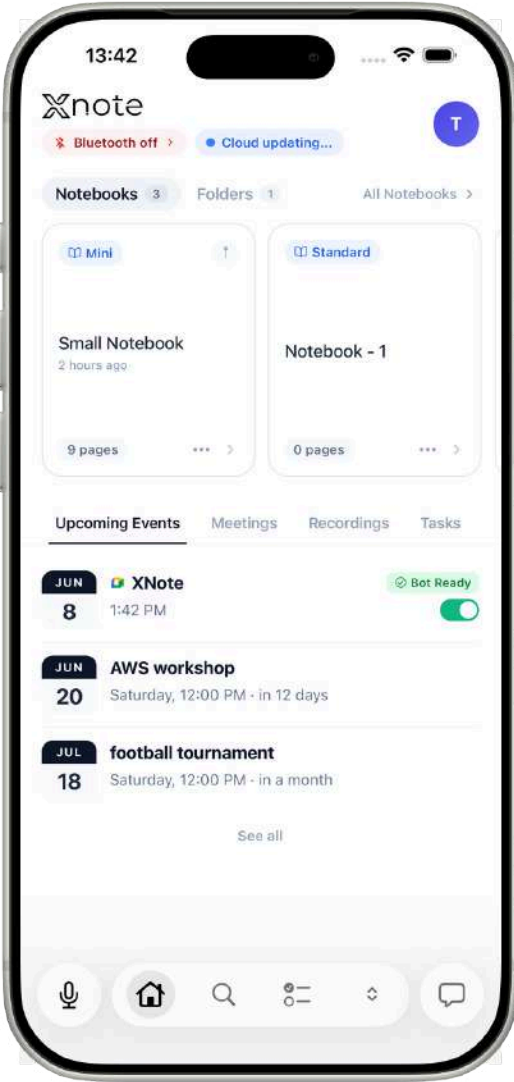

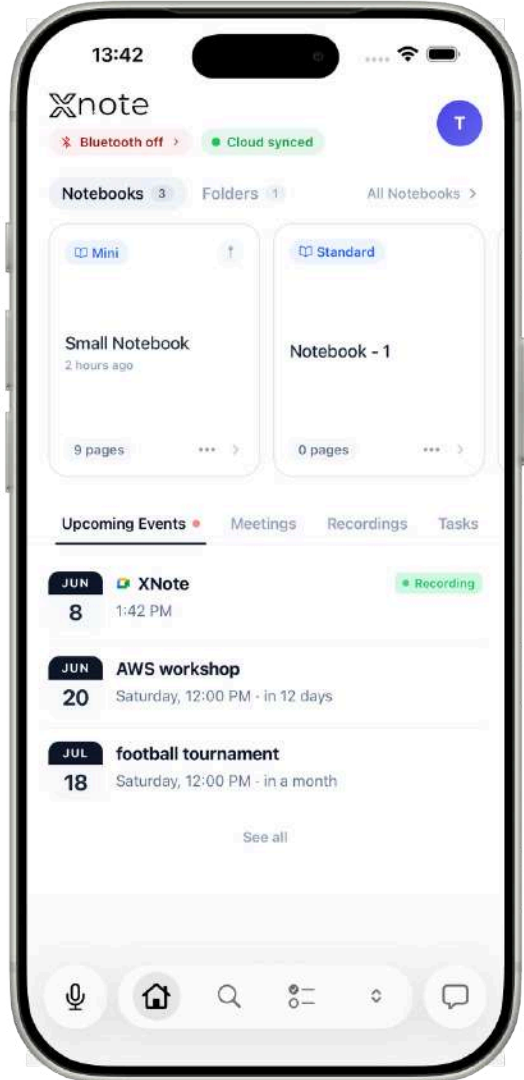
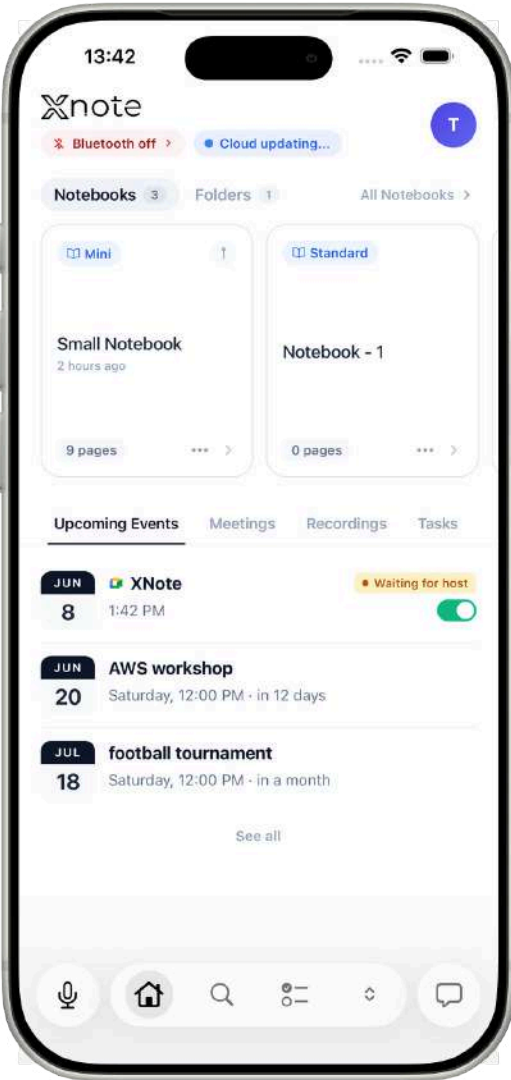

## 2.8.3 Audio Session Detail

Tap any audio session to open the detail screen. The detail screen has three tabs:

### Overview Tab:

- Shows the AI-generated summary ([see 2.8.4](#))

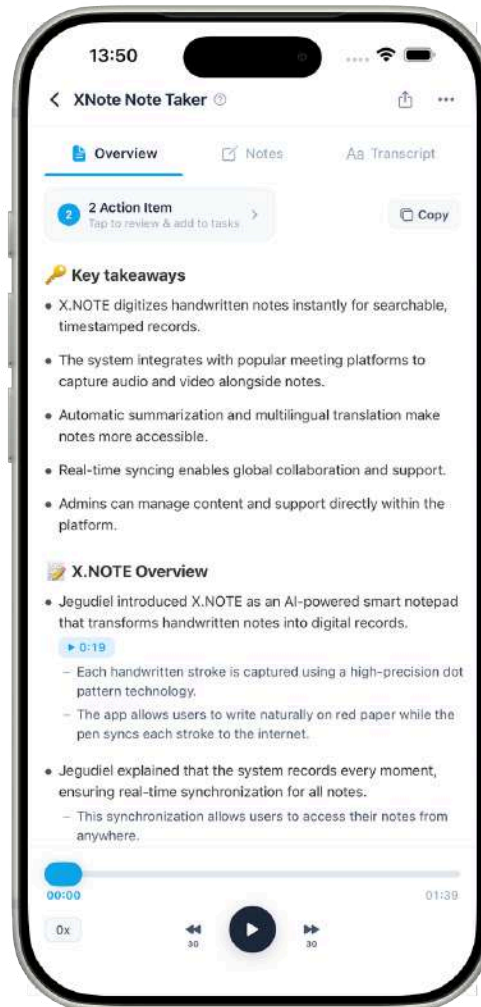

- If the upload failed but the file is still on your device, a retry button is shown
- If processing failed, a retry button allows you to re-trigger transcription
- Action items banner shows the count of items remaining to add to Tasks

## Notes Tab:

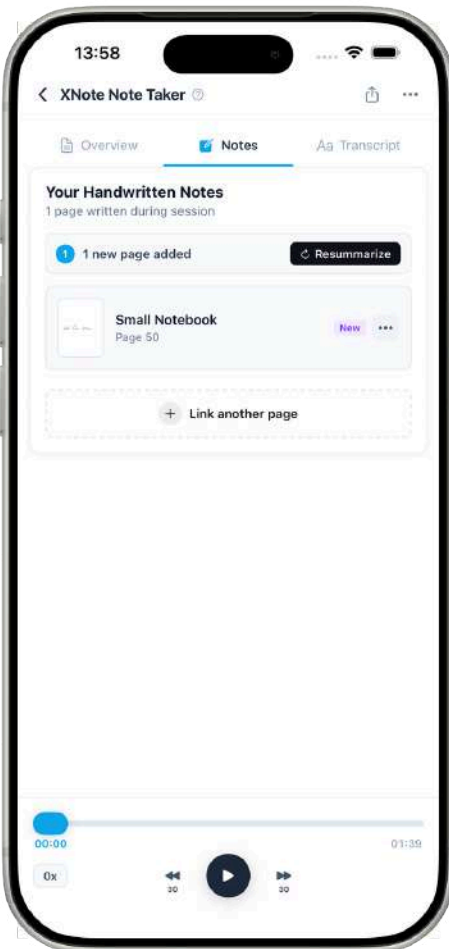

- Shows notebook pages linked to this recording ([see 2.8.7](#))
- Each page shows a thumbnail, notebook name, page number, and a status badge (Auto, Included, or New)
- Tap a page to view it. Long-press for options: view page or unlink from recording
- If new pages were added after the summary was generated, a banner prompts you to regenerate the summary
- Tap **"Link Pages"** to add more pages

### Transcription Tab:

- Shows the full transcript grouped by speaker ([see 2.8.5 for renaming](#))
- Each speaker group shows the speaker name, start timestamp, and spoken text
- Tap any sentence or timestamp to jump to that point in the audio
- The currently playing sentence is highlighted in green with a smooth animation
- A floating **"Live"** button appears when the active speaker scrolls out of view tap it to auto-scroll back

### Audio Player:

A persistent audio player is displayed at the bottom of the detail screen:

- Play/Pause button
- Rewind 30 seconds and Forward 30 seconds buttons
- Scrubber/slider to seek through the audio
- Current time and total duration display
  
- Playback speed selector: 0.5x, 0.75x, 1.0x, 1.25x, 1.5x, 1.75x, 2.0x

### Session Options:

Tap the "..." (more) button in the header to access:

- Rename Title : Change the session title
- Re-transcribe : Re-run transcription with a different template (requires quota)
- Re-summarize : Regenerate the AI summary
- Edit Summary : Edit the summary text manually
- Rename Speakers : Rename identified speakers ([see 2.8.5](#))
- Delete : Delete the recording with confirmation dialog

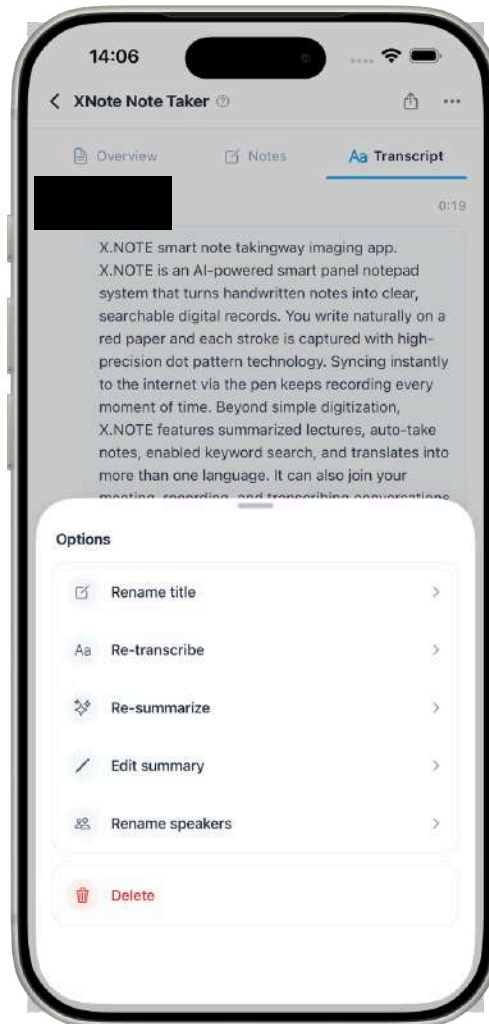

Share:

Tap the share icon in the header to share the recording ([see 2.8.8](#)).

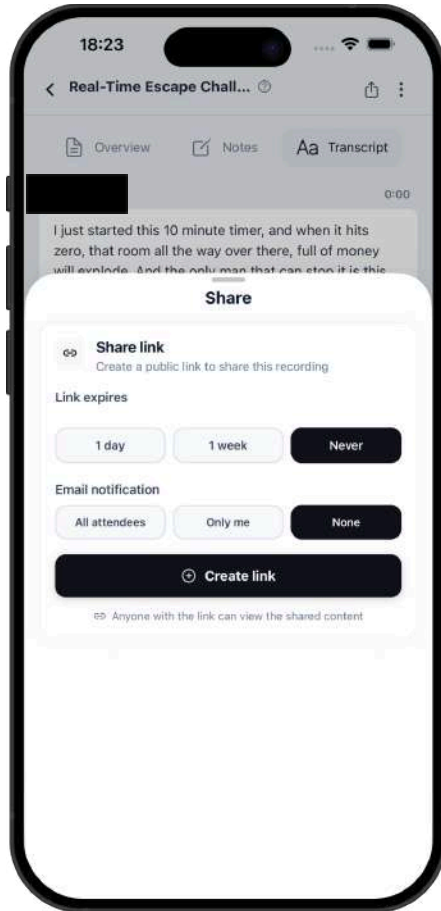

Help:

Tap the session title at the top to open the Audio Session Help page a built-in guide explaining the audio processing pipeline (uploading → transcribing → summarizing → ready), how each tab works, page linking and badges (Auto, Included, New), audio player controls, session options, and frequently asked questions.

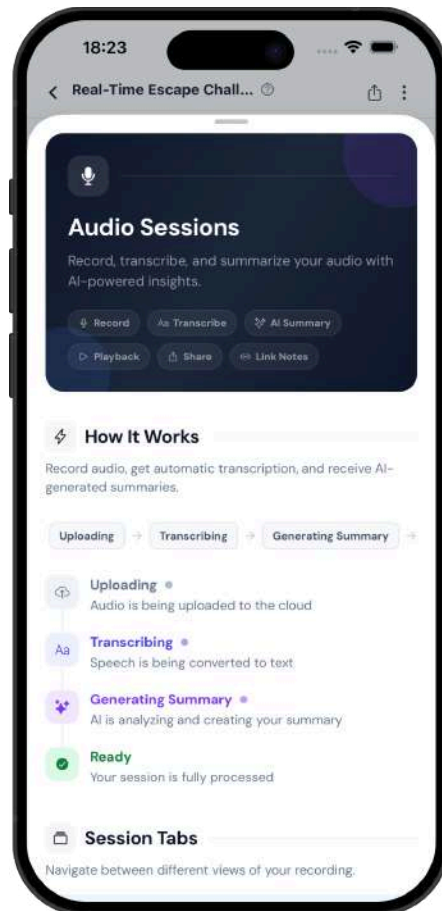

## 2.8.4 Summary & Templates

After a recording is complete, select a summary template to start transcription and AI summary generation.

1. Open the audio session.
2. Choose a template (Default, Meeting Notes, Action Items, etc.).

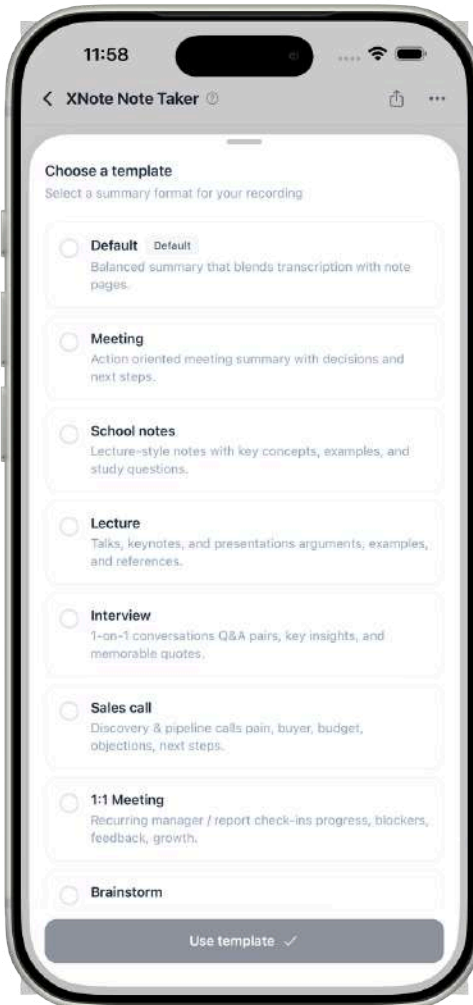

3. Transcription and summary generation begin automatically.

Available templates include:

- Default (general purpose)
- Meeting Notes
- School Notes
- Lecture
- Interview
- Sales call

- 1:1 Meeting
- Brainstorm
- Action Items
- Key Points

The summary is shown in the Overview tab of the audio session, rendered as formatted text.

To edit the summary:

1. Tap "... " in the header and select **"Edit Summary"**.
2. A full-screen editor opens with the current summary text.
3. Modify the text and tap **"Done"** to save, or **"Cancel"** to discard changes.

To regenerate:

- Re-transcribe : Runs transcription again with a new template (uses audio minutes)
- Re-summarize : Regenerates only the summary from existing transcription

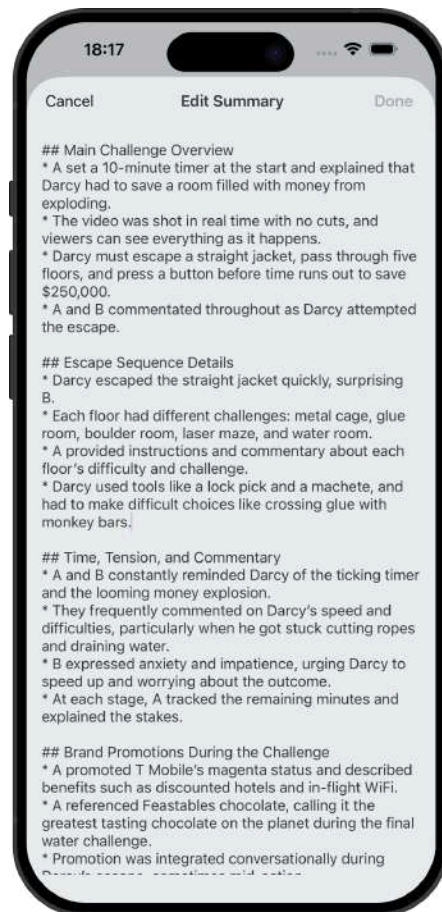

## 2.8.5 Speaker Identification & Renaming

XNote automatically identifies different speakers in the recording (Speaker 1, Speaker 2, etc.).

To rename speakers:

1. Open the audio session.
2. Tap the "... " menu and select **"Rename Speakers"**.
3. For each speaker, you will see sample utterances to help you identify them.
4. Enter the speaker's name and navigate to the next speaker.
5. Tap **"Save All"** to apply.

Speaker names must be unique.

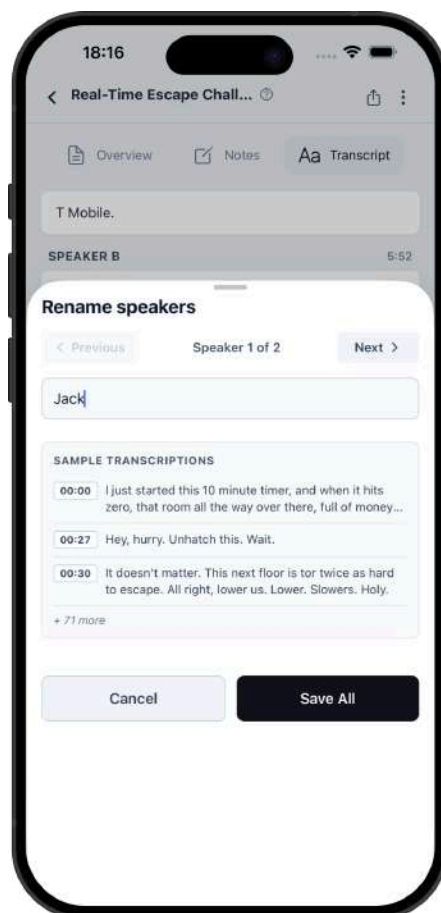

## 2.8.6 Action Items

XNote extracts action items from the recording using AI.

Each action item shows:

- Task description
- Assigned person (if identified)
- Due date (if mentioned)
- Priority level (high / medium / low)

Tap the "+" button on an action item to save it to your Tasks ([see 2.11](#)). The task will be linked to the source recording. Already-added items show a disabled state. When all action items are added, a checkmark confirms completion.

An action items banner in the Overview tab shows how many items remain to be added.

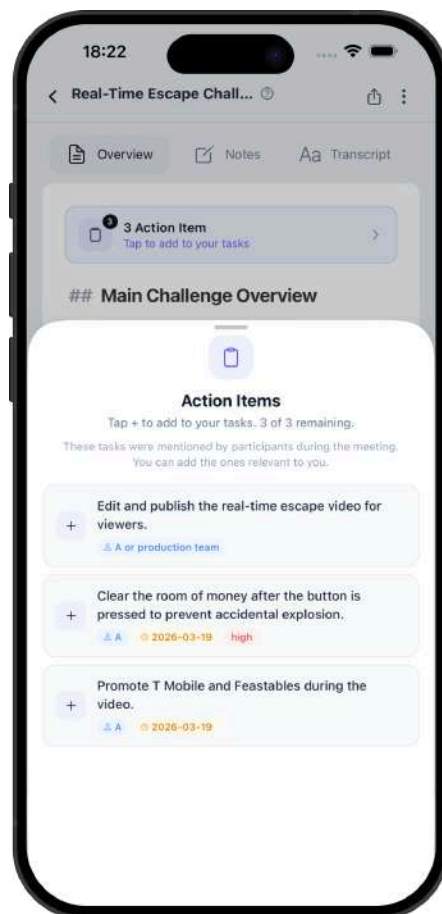

## 2.8.7 Link Pages to Recording

You can link notebook pages to an audio session for quick reference.

1. Open the audio session and go to the Notes tab.
2. Tap **"Link Pages"** or the add button.
3. Select pages from your notebooks.

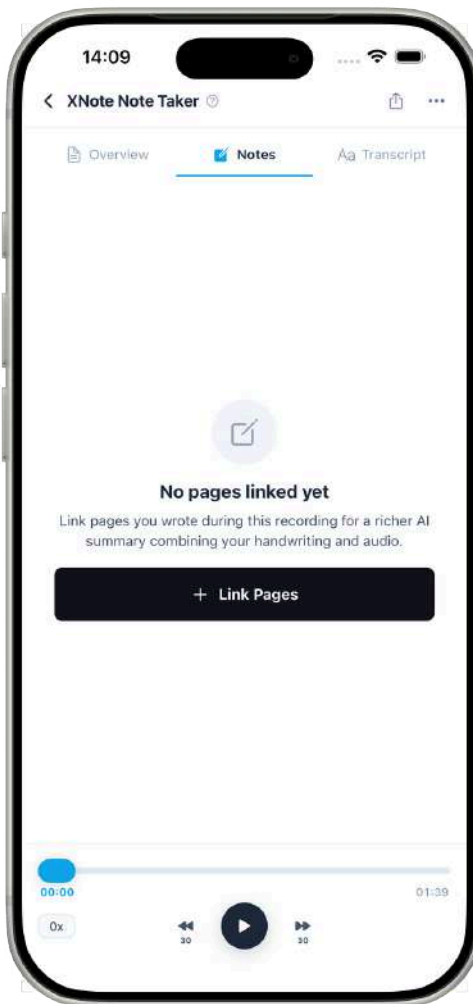

4. Tap **"Link X Pages"** to confirm.

Linked pages appear in the Notes tab with status badges:

- Auto : Automatically linked based on writing during the recording
- Included : Included in the AI summary context
- New : Newly added after the summary was generated

To unlink a page, long-press (iOS) or tap the three-dot menu (Android) on the page and select **"Unlink"**.

If pages are added or removed after the summary was generated, a banner will prompt you to regenerate the summary with the updated pages.

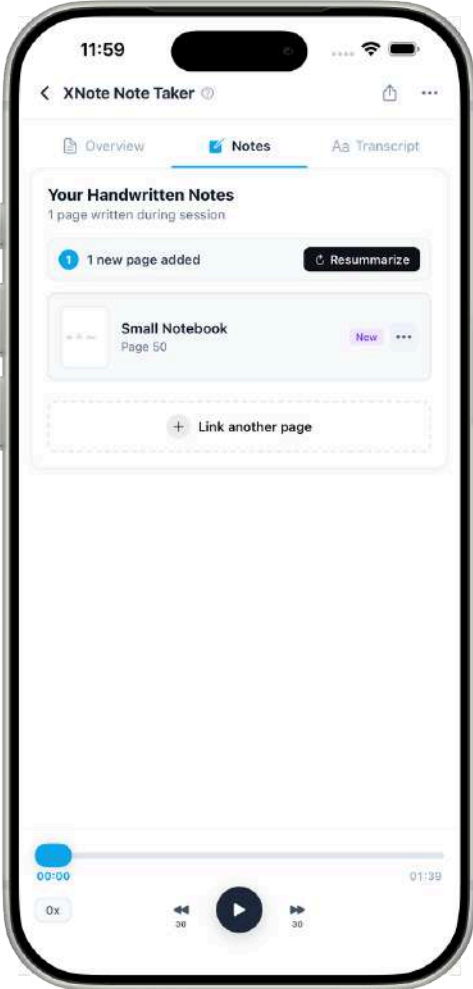

## 2.8.8 Share & Audio Minutes

Share a Recording:

1. Open an audio session and tap the share icon in the header.
2. Select an expiration: 1 day, 7 days (default), or Never.
3. Choose who to notify by email: All attendees, Only me (default), or None.
4. Tap **"Create Link"**.

The shared link includes the AI-generated summary and meeting metadata. The actual audio file remains private and is not included.

Note: A summary must exist and the session must not be processing to create a share link.

Once a link is created, you can:

- Copy the link to clipboard
- Share via the system share sheet

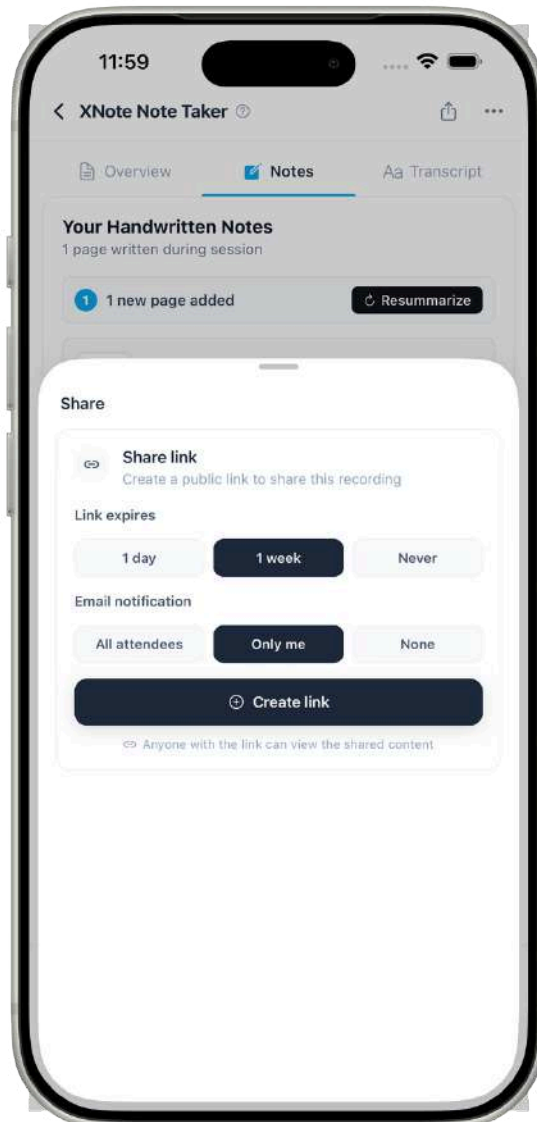

- Revoke the link to disable access immediately

Audio Minutes & Limits:

Transcription uses audio minutes from your plan. For plan details and limits, [see 4.1](#)

To view your usage, go to Settings → Subscription → Audio Details. You will see:

- Total remaining minutes
- Monthly limit and usage
- Next reset date
- Add-on minutes balance

When minutes are low:

- Orange warning when less than 5 minutes remain
- If a recording exceeds your remaining quota, you can choose partial transcription or purchase more minutes
- When fully exhausted, a red banner prompts you to get more minutes

## 2.9 AI Chat

XNote includes an AI assistant that can analyze your handwritten notes, generate summaries, create flashcards, translate content, and visualize data.

Access AI Chat from the AI Chat tab in the bottom navigation bar.

### 2.9.1 Start a Conversation

When you open AI Chat, you will see a personalized greeting with your name and four quick access feature cards: Summarize, Flashcards, Translate, and Chart.

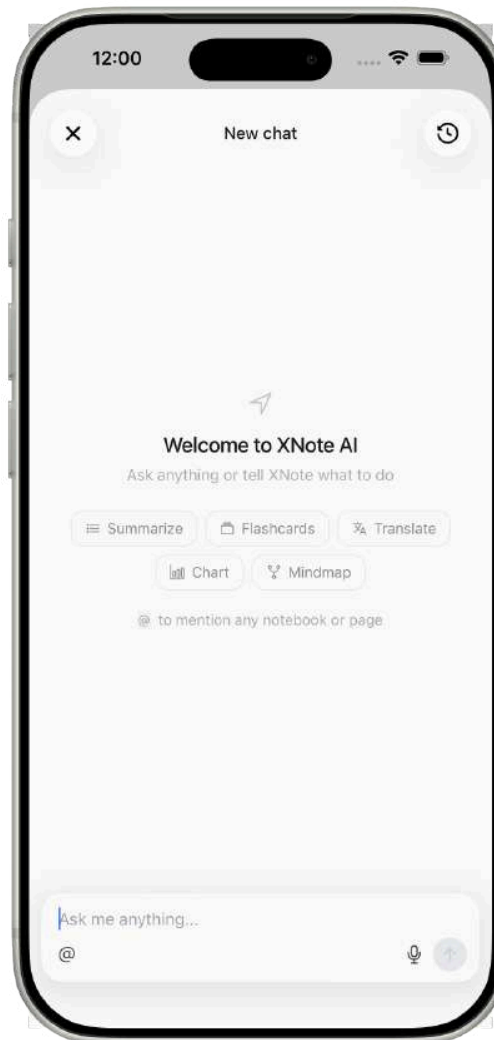

You can interact with AI in two ways:

Text input : Type your question or request in the message field. The send button (arrow icon) appears when text is entered.

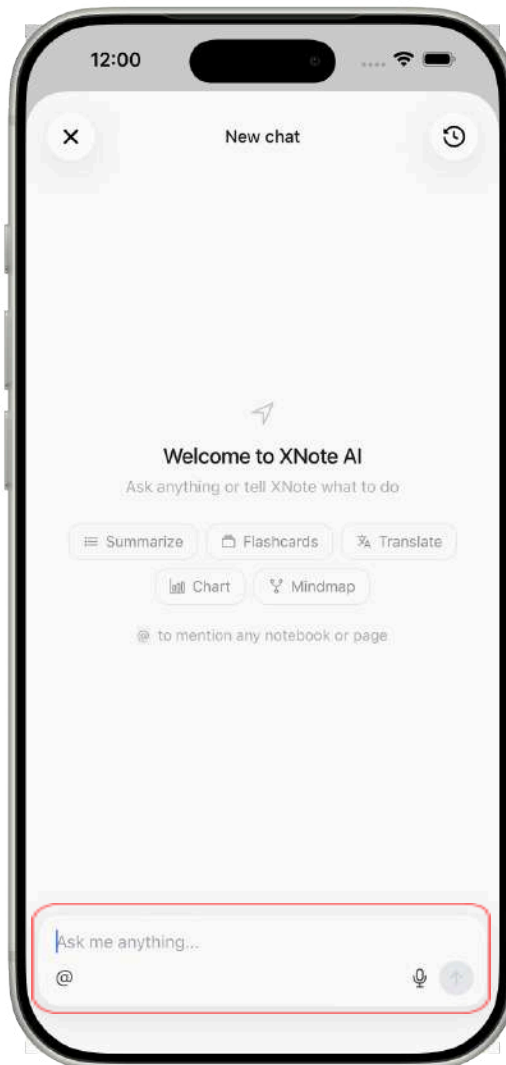

Voice input : When the input field is empty, a microphone icon appears instead of the send button. Tap it to start recording:

- An animated wave visualization with a recording timer (MM:SS) is shown while recording
- Tap the stop icon to end the recording
- Your speech is automatically transcribed and inserted into the input field

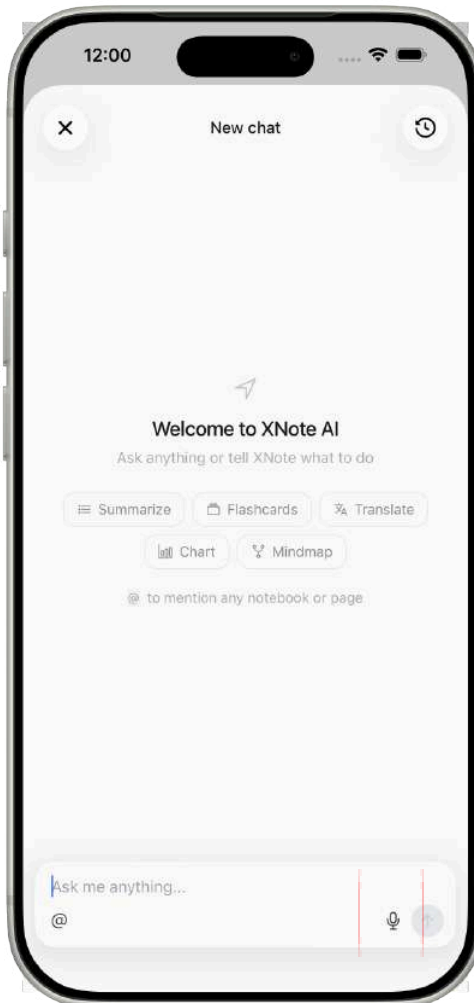

To start a new conversation, tap the edit icon in the top-right corner of the header. This clears the current chat and returns to the empty state.

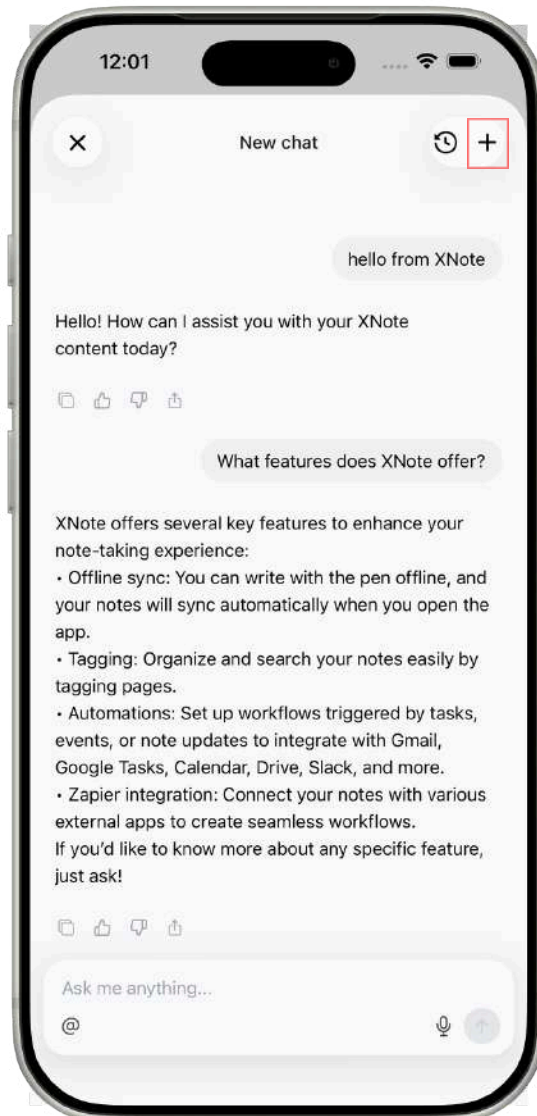

AI responses stream in real-time. After each response, suggested follow-up questions may appear.

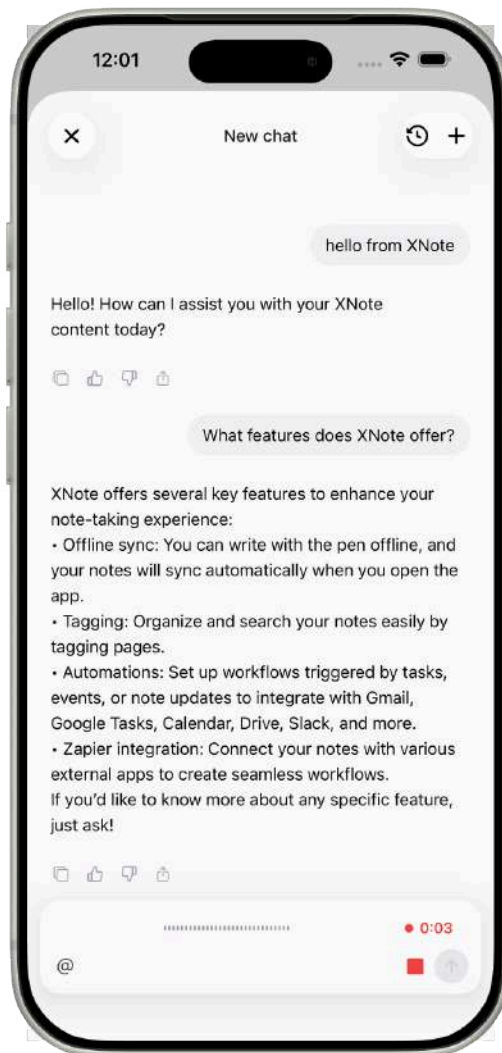

## 2.9.2 Mention Pages in Chat

You can reference specific notebook pages in your message so the AI can analyze their content.

Type "@" in the input field to open the mention suggestions:

- The suggestion list shows your 5 most recently updated notebooks and 3 most recent pages
- Type a keyword after "@" to search by notebook title or page number
- Select a page to insert it as a mention badge in your message

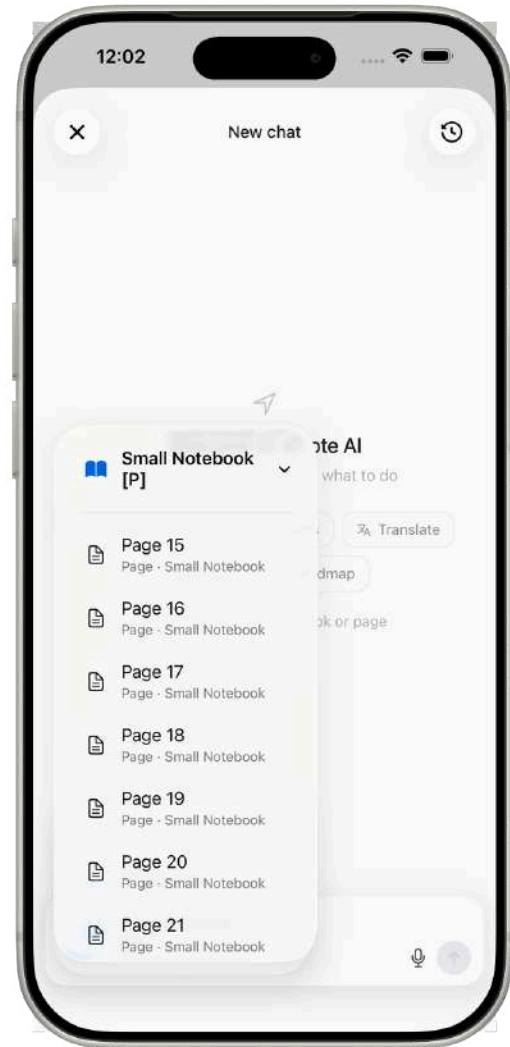
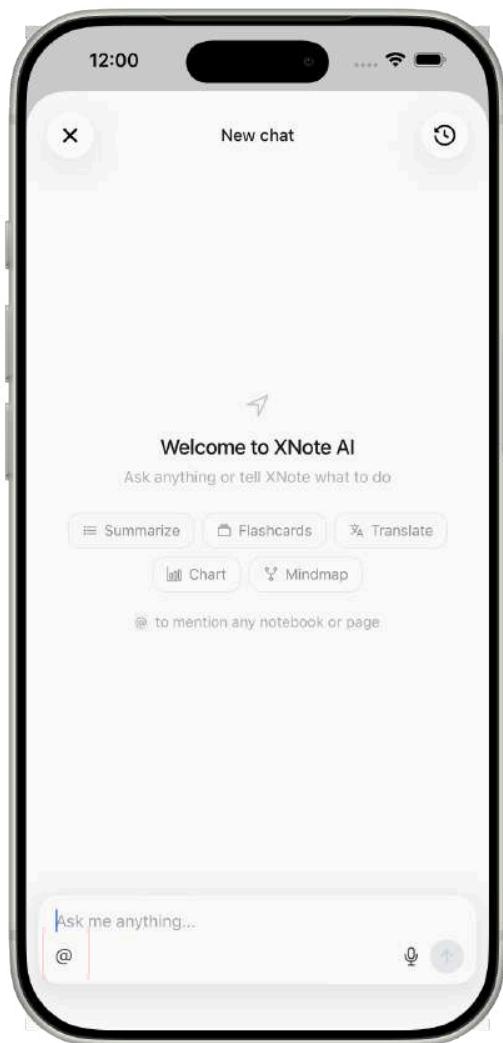

Tap the "@" button (left of the input field) to browse and select pages from a visual notebook picker:

- All notebooks are listed with their page count. Primary notebooks are marked with a "[P]" badge.
- Select pages from any notebook

You can mention up to 15 pages per message. A counter shows the current count and turns red when the limit is reached. The "+" button becomes dimmed when the limit is reached.

## 2.9.3 Summarize

Generate a concise summary from your handwritten notes.

1. Tap the Summarize card or start from any chat.

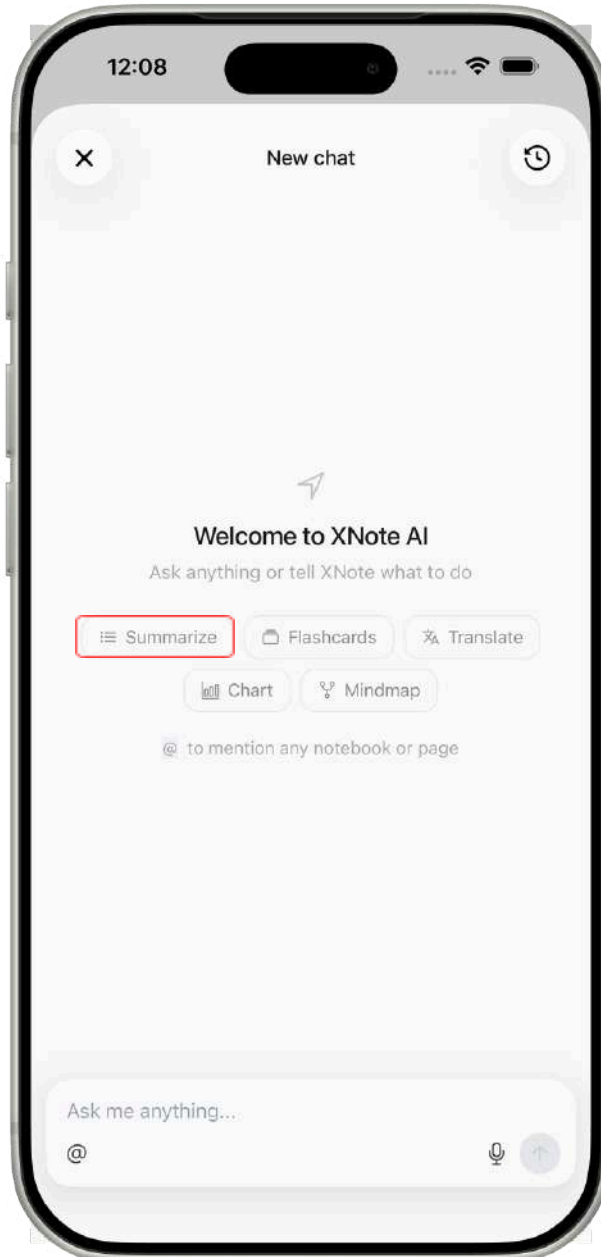

2. Select up to 15 pages from your notebooks. A counter shows your selection (e.g., "3/15").

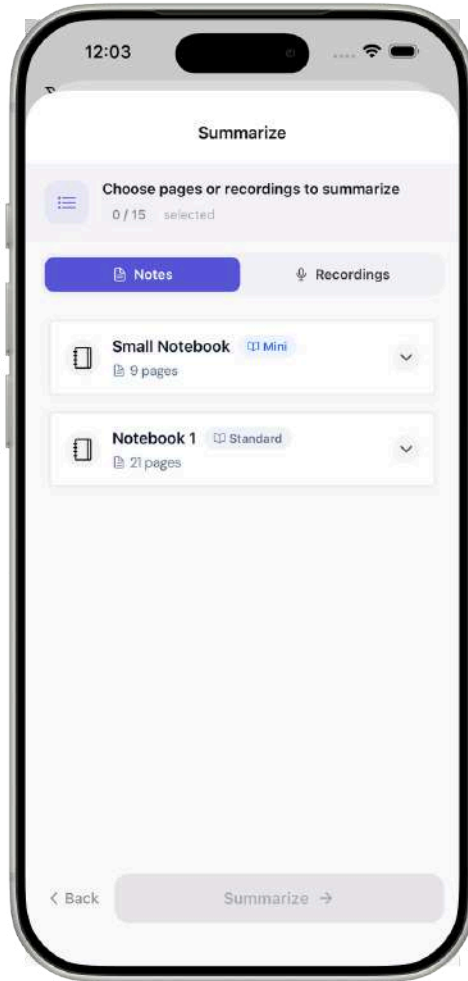

3. Tap **"Summarize"** to send.

4. AI will analyze the content and return a comprehensive summary.

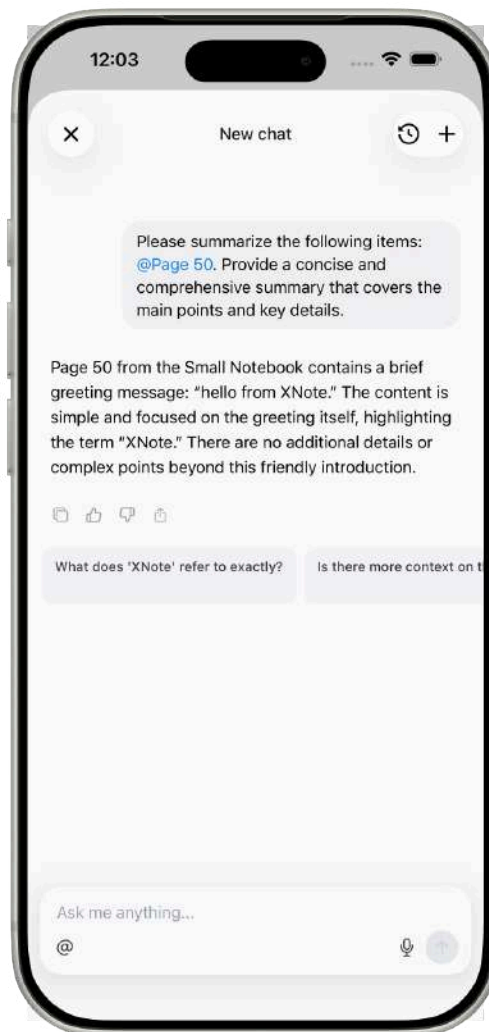

## 2.9.4 Flashcards

Create study flashcards from your notes.

1. Tap the Flashcards card.

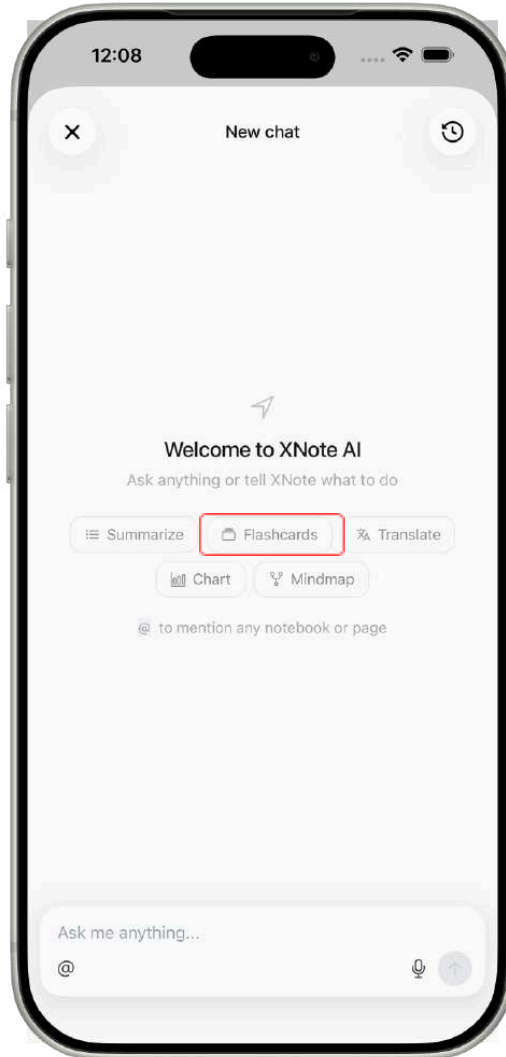

2. Select how many flashcards to generate by tapping one of the count buttons: 5, 10, 15, 20, or 25. The selected count is highlighted in orange.

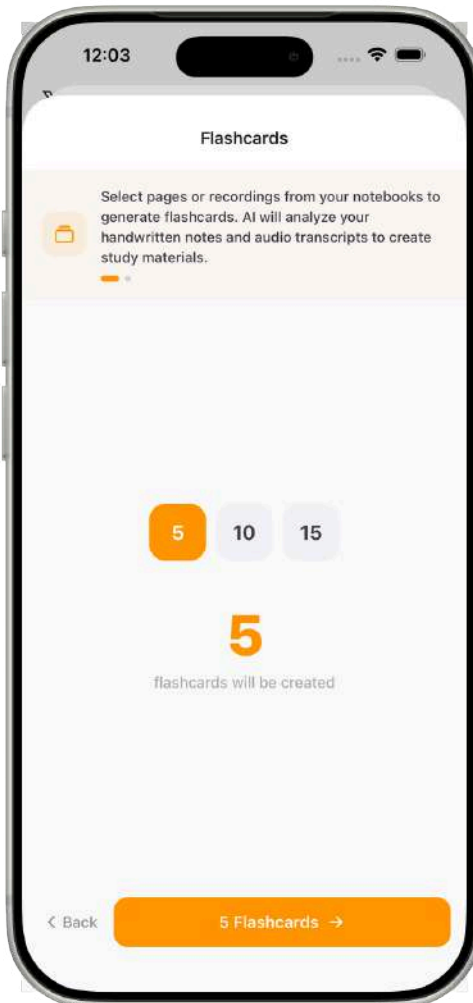

3. Tap **"Next"** to proceed to page selection.
4. Select up to 15 pages.
5. AI generates question-and-answer pairs based on your content.

12:04

## Flashcards

### Review Cards

1/5

What is necessary to check for the new system?

💡 Think about system maintenance.

Next Card

### All Cards (5)

1

Question

What is necessary to check for the new system?

Answer

A new system check is needed.

2

Question

What specific UI update needs to be checked?

Answer

The XNote UI update needs to be checked.

3

Question

What is the context of the phrase 'hello from XNote'?

Answer

It is a greeting related to XNote.

4

Question

## 2.9.5 Translation

Translate your note content into another language. Supports 32 languages with native name display. You can search languages by English name or native name.

Available languages include: Arabic, Bengali, Chinese (Simplified), Czech, Danish, Dutch, English, Finnish, French, German, Greek, Hebrew, Hindi, Hungarian, Indonesian, Italian, Japanese, Korean, Malay, Norwegian, Persian, Polish, Portuguese, Romanian, Russian, Spanish, Swedish, Thai, Turkish, Ukrainian, Urdu, and Vietnamese.

1. Tap the Translate card.

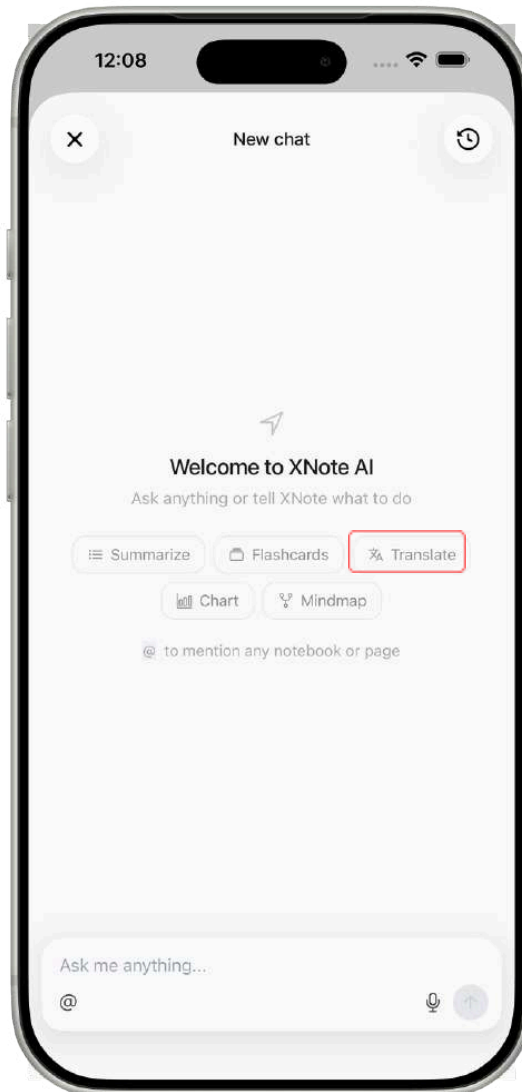

2. Search or browse the language list. Each language shows its English name and native name (e.g., "**Chinese**").
3. Select the target language (a checkmark confirms your selection).

12:04

## Translate

 Select target language

 Search languages...

**Arabic**  
العربية

**Bengali**  
বাংলা

**Chinese**  
中文 (简体) 

**Czech**  
Čeština

**Danish**  
Dansk

**Dutch**  
Nederlands

**English**  
English

**Finnish**  
Suomi

**French**

[← Back](#)

[Next: Chinese →](#)

4. Select up to 15 pages.

5. AI returns the translated content in the chat.



## 2.9.6 Chart Generation

Visualize data from your notes as charts. Four chart types are available:

- Bar Chart : Compare values across categories (scrollable for large datasets)
- Line Chart : Track changes over time (scrollable, shows data point values)
- Pie Chart : Show percentage distributions (interactive tap a slice to highlight it)
- Scatter Plot : Plot X,Y coordinates to find patterns

1. Tap the Chart card.

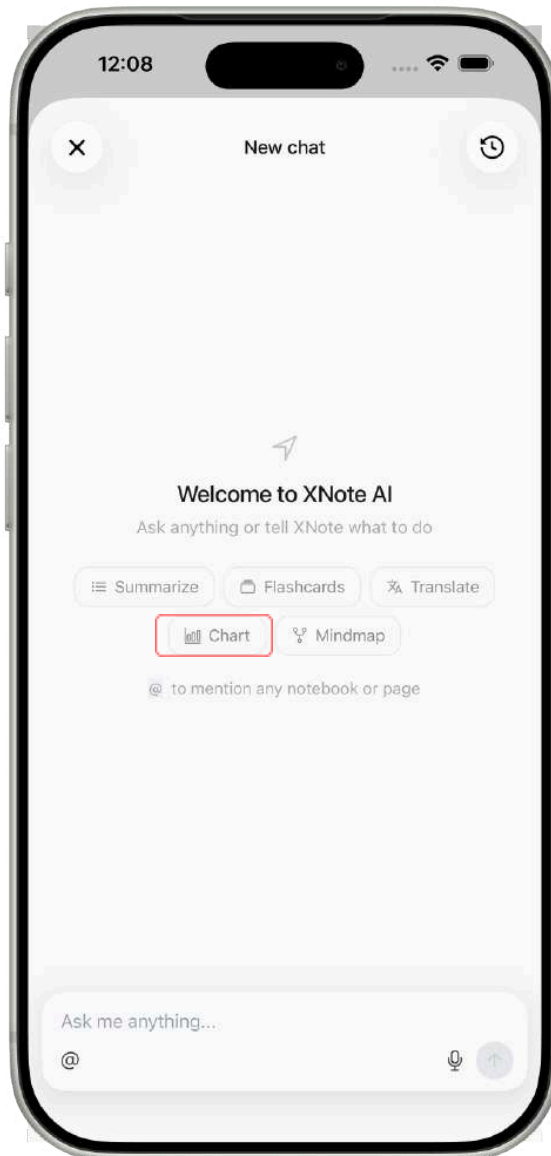

2. Select a chart type from the 2x2 grid. Each card shows an icon and description.

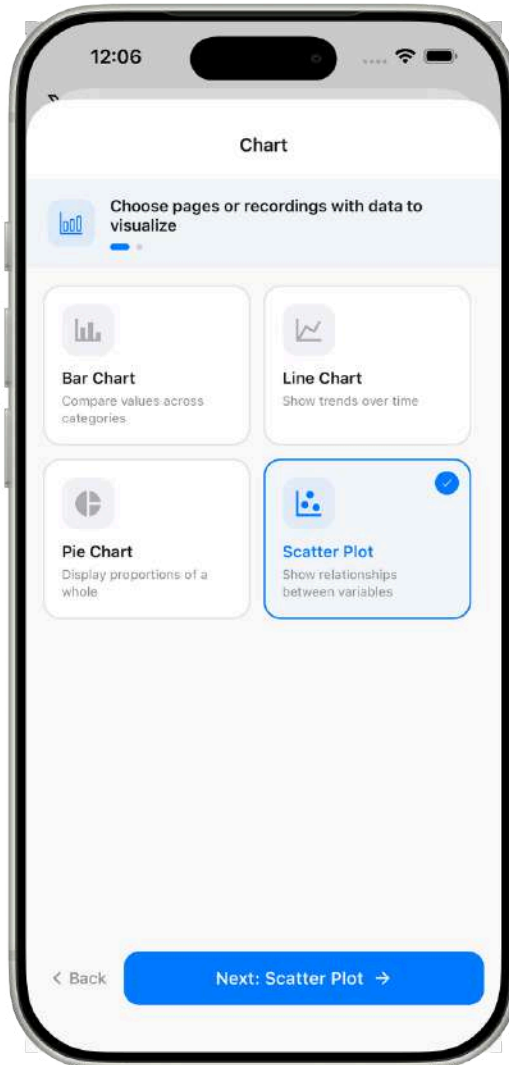

3. Select up to 15 pages containing data.

4. AI generates the chart and displays it in the chat with an AI-generated description below.

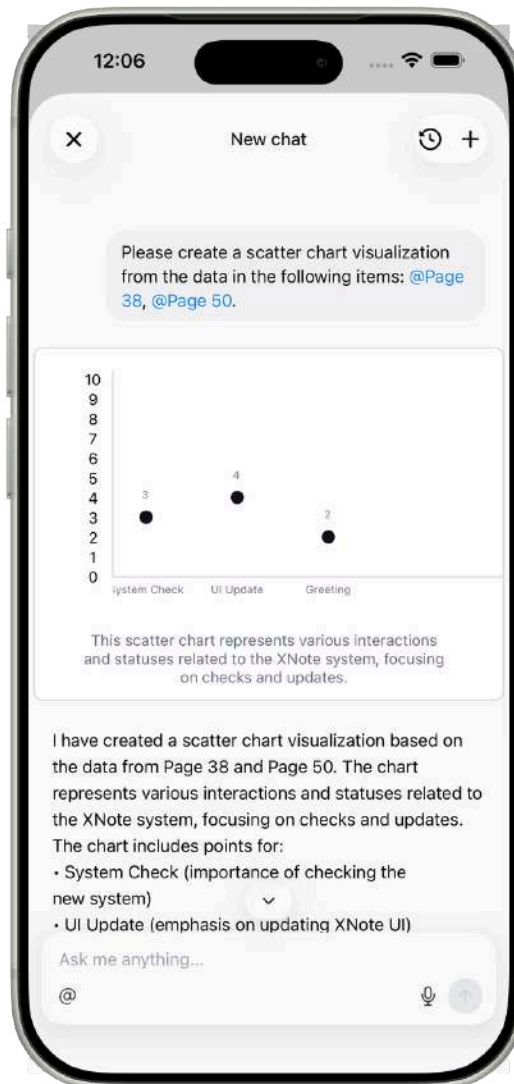

## 2.9.7 Mind Map Generation

Turn your notes into a visual mind map that organizes ideas into a hierarchical structure. A mind map starts from a central topic and branches outward into related subtopics, helping you see connections and group related concepts at a glance.

1- Tap the Mind Map card.

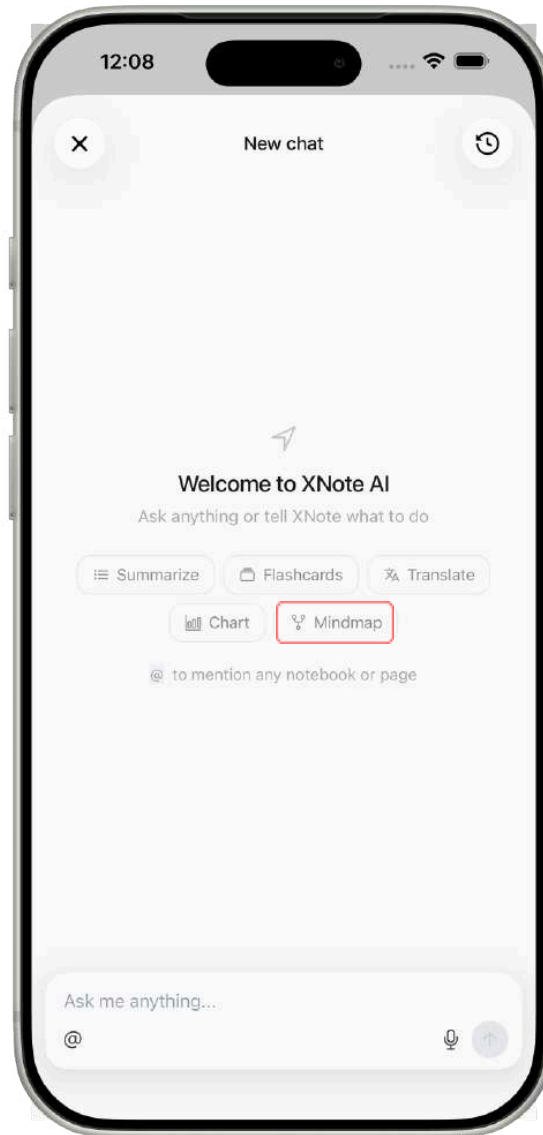

2- Select a depth level to control how many branch layers the map expands (e.g., main topics only, or main topics with detailed sub-branches).

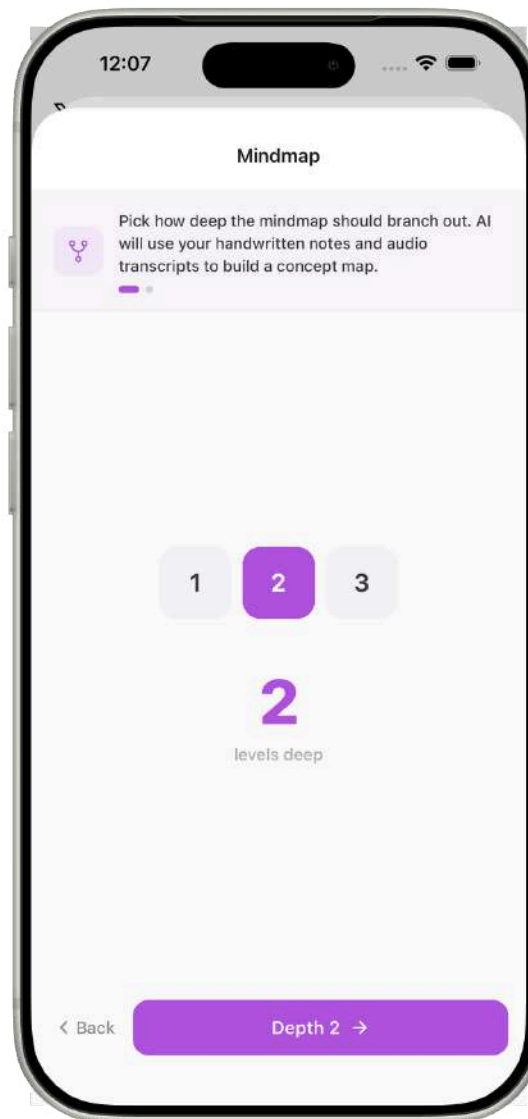

3-Select up to 15 pages containing the notes you want to map.

4-AI generates the mind map and displays it in the chat with an AI-generated description below.

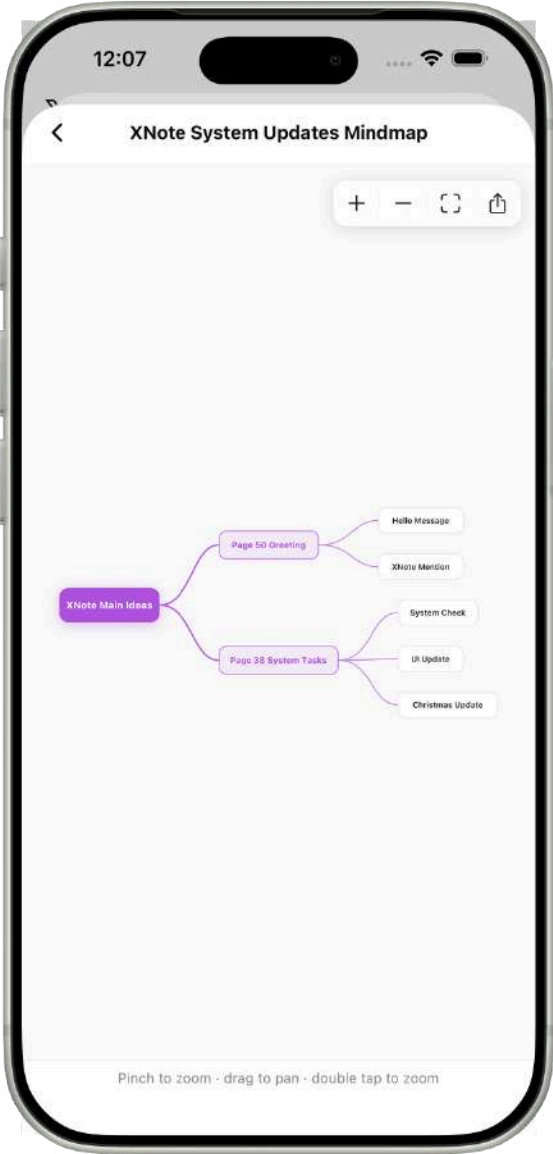

## 2.9.8 Chat History

All conversations are saved automatically. To view past chats:

1. Tap the conversation title or the chevron icon at the top of the chat screen.

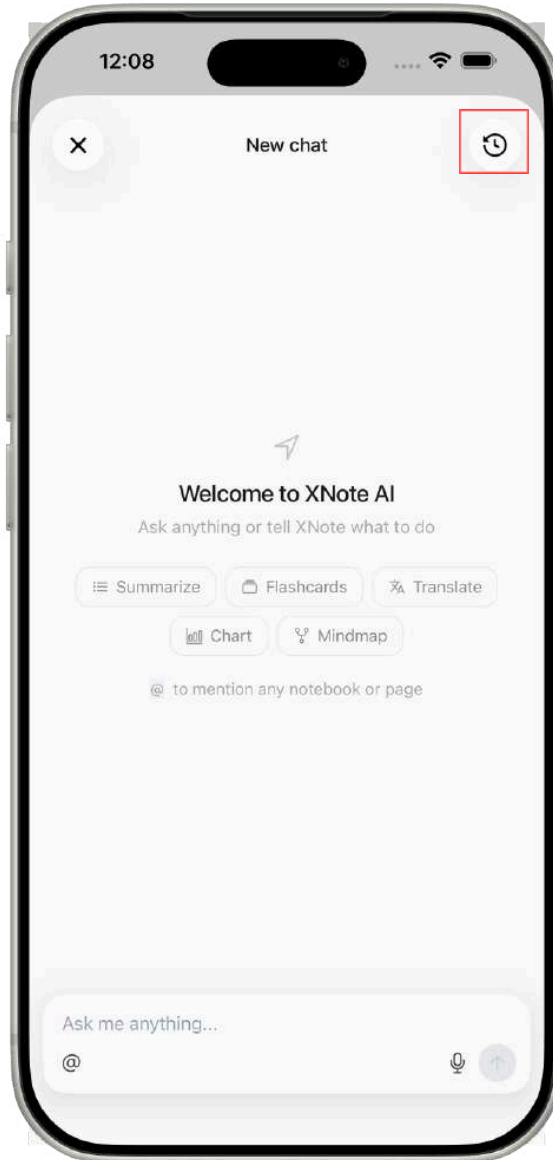

2. A side drawer opens (86% of screen width) showing your chat history grouped by time:

- Today
- Previous 3 Days
- Previous 7 Days
- Previous 30 Days
- Older

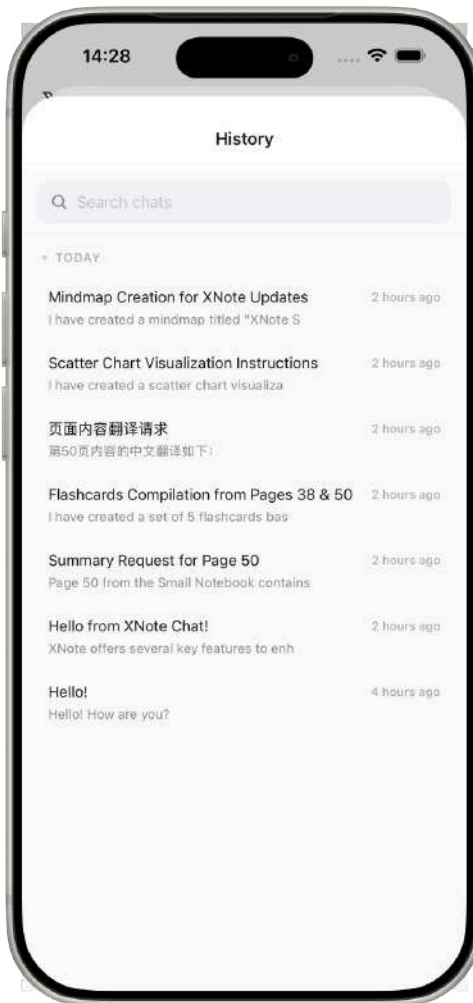

3. Use the search bar to find a specific conversation by title.

4. Tap a chat to reopen it. The active chat is highlighted with a left indicator bar.

5. Tap **"Load More"** at the bottom to load older conversations (10 per page).

Conversations cannot be deleted from the history drawer.

When no chats exist, a **"You haven't started any chats yet"** message is shown.

## 2.10 Search

The Search tab lets you find pages across all your notebooks using text, topics, or tags.

Tap the info icon in the header to open the Search Help page a built-in guide explaining search types (text search, hashtag search, topic search), how the hashtag system works, valid hashtag examples, manual tag creation, and frequently asked questions.

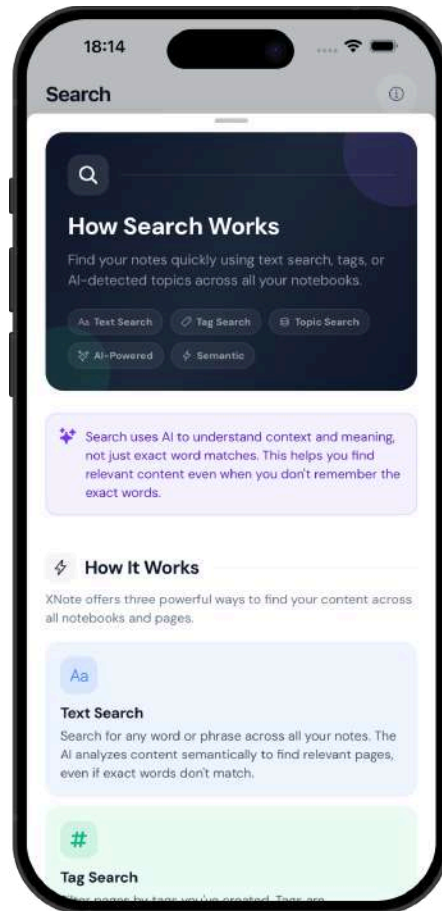

When no search is active, the search home screen displays three sections: Recent Searches, Tags, and Topics.

## 2.10.1 Full-Text Search

Type at least 2 characters in the search bar to search across all your pages. Search results update automatically after a brief delay.

Results appear in a responsive grid (1-2 columns depending on device). Each result shows:

- Page thumbnail (handwriting preview)
- Notebook name badge (bottom-left corner)
- Page number badge with document icon (bottom-right corner)

Tap a result to open the page in its notebook. Search does not highlight matched text within the thumbnail. It returns pages whose OCR content matches your query.

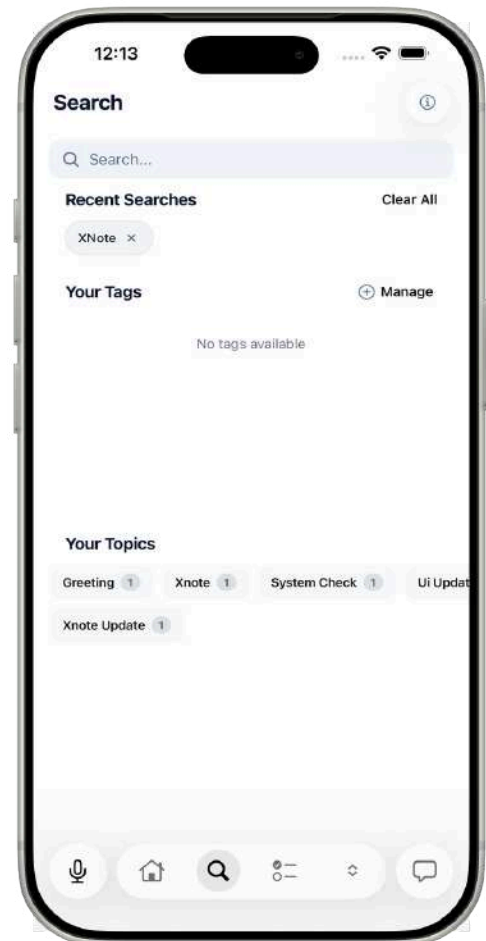

## 2.10.2 Topic-Based Search

XNote automatically extracts topics from your notes using AI. On the search home screen, topic chips are displayed in a horizontal scrollable list (up to 12 visible). Each chip shows the topic name and a count badge indicating how many pages contain that topic.

Tap a topic to filter results by that topic the chip highlights to show it is selected. Tap it again to deselect.

Tap **"See All Topics"** to open the All Topics screen, which displays all extracted topics. Tapping a topic on this screen returns you to the search results filtered by that topic.

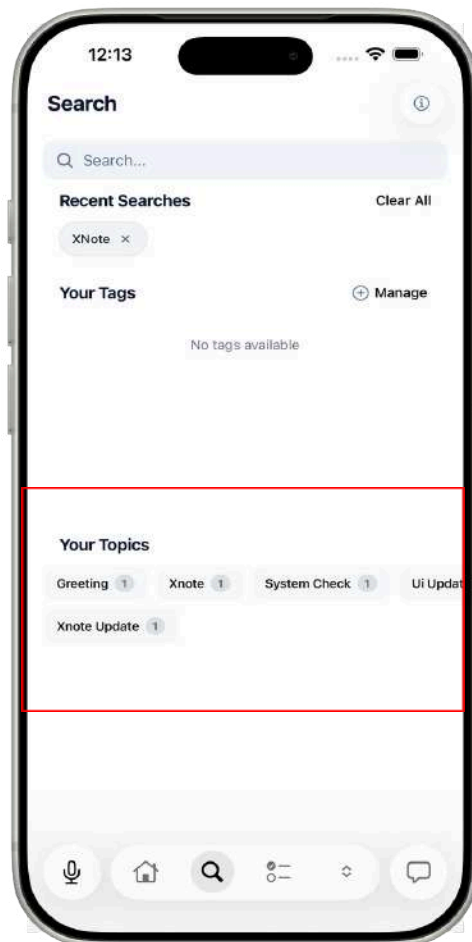

## 2.10.3 Tag-Based Filtering

Tags you have created are displayed on the search home screen as colored chips with a "#" prefix (e.g., #work). Up to 6 tags are shown (2 per row, 3 rows). Tap a tag to filter pages by that tag.

- Tap **"Manage"** to open the Tag Management screen where you can create, edit, and delete tags ([see 2.14.5](#))

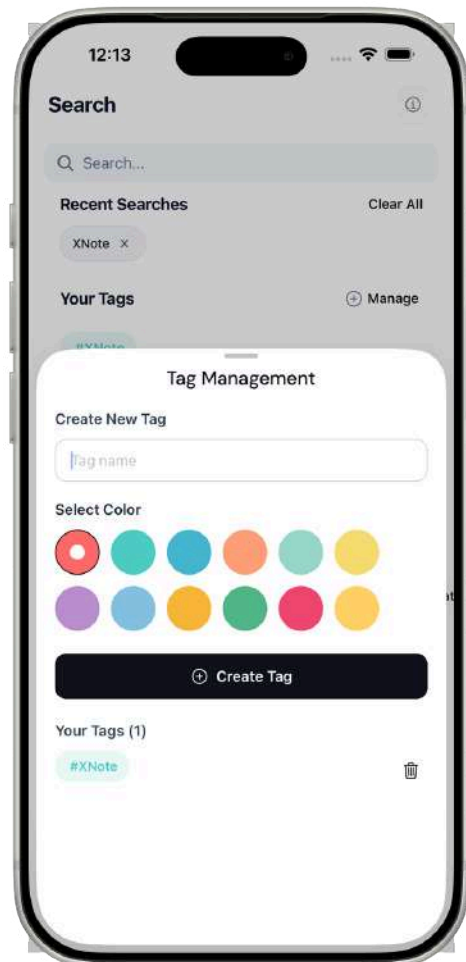
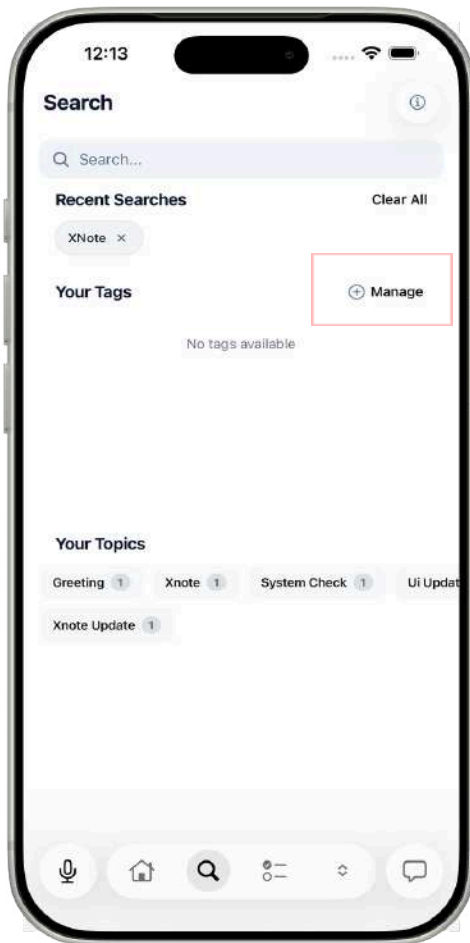

## 2.10.4 Recent Searches

Your recent searches are saved automatically and displayed as horizontally scrollable chips at the top of the search screen. You can:

- Tap a chip to re-run that search
- Tap the x icon on a chip to remove it
- Tap **"Clear All"** to delete all recent searches

Up to 10 recent searches are stored. Duplicate searches (case-insensitive) are moved to the front of the list.

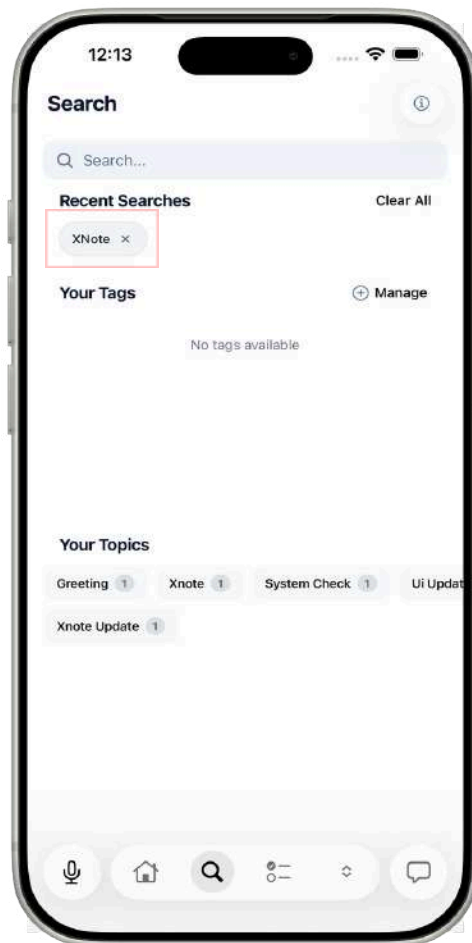

## 2.11 Tasks

The Tasks tab displays all your tasks in a list view. Tasks can be created from audio recordings, page annotations, or AI extraction.

### 2.11.1 View & Filter Tasks

Tasks are shown in a vertical list. Each task displays:

- Checkbox for completion (green when checked, completed tasks show strikethrough title at reduced opacity)
- Task emoji (if set) or source icon (microphone for audio, checkbox for page)
- Title
- Priority badge (red = high, orange = medium, green = low)
- Source badge (Meeting or notebook name)
- Due date (red if overdue)
- Todoist sync indicator (small Todoist icon, if synced)
- Three-dot menu button

Tap the three-dot menu on any task row for quick actions:

- Mark as completed / Mark as incomplete
- Go to page (navigate to the source page or recording)
- Delete (with confirmation dialog)

Tap the info icon in the header to open the Tasks Help page a built-in guide explaining how XNote recognizes tasks from your handwriting, valid task formats, checkbox usage, priorities, deadlines, and frequently asked questions.

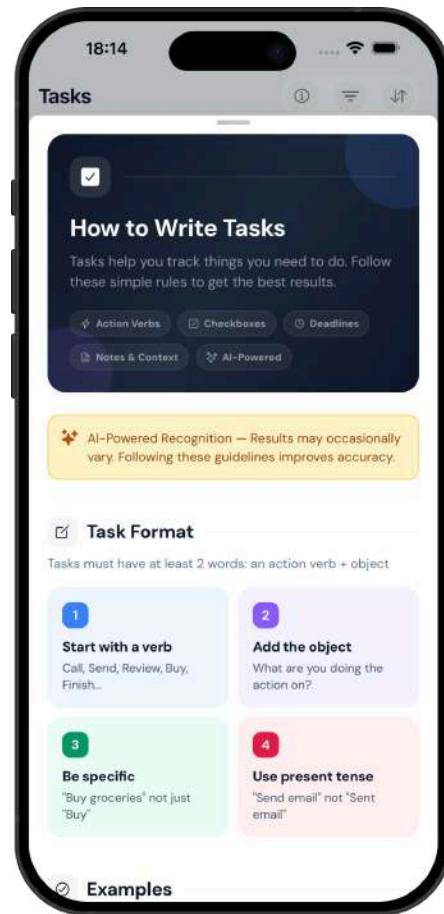

Filter by:

- Status : Incomplete (default) or Completed using the top filter tabs
- Advanced filters : Tap the filter button to open the filter screen where you can filter by status, notebook, and priority simultaneously
- Tap "**Clear filters**" to reset all active filters

## 2.11.2 Create / Edit / Delete Tasks

Tasks are primarily created automatically from:

- Audio recordings : AI extracts action items from transcriptions ([see 2.8.6](#))
- Page content : Tasks linked to specific pages

Tap a task to open its detail sheet. The detail sheet is read-only you cannot edit the title, priority, due date, or emoji. It displays:

- Task emoji and title
- Priority, due date, and status pills
- Source link : **"Go to Audio"** for audio tasks (navigates to the recording), or page number link for page tasks (navigates to the notebook page)
- Todoist link : If synced, **"View on Todoist"** opens the task in the Todoist app or website

Available actions in the detail sheet:

- Add to Todoist (if Todoist is connected and task not already synced) ([see 2.11.4 for details](#))
- Mark as Complete / Mark as Incomplete

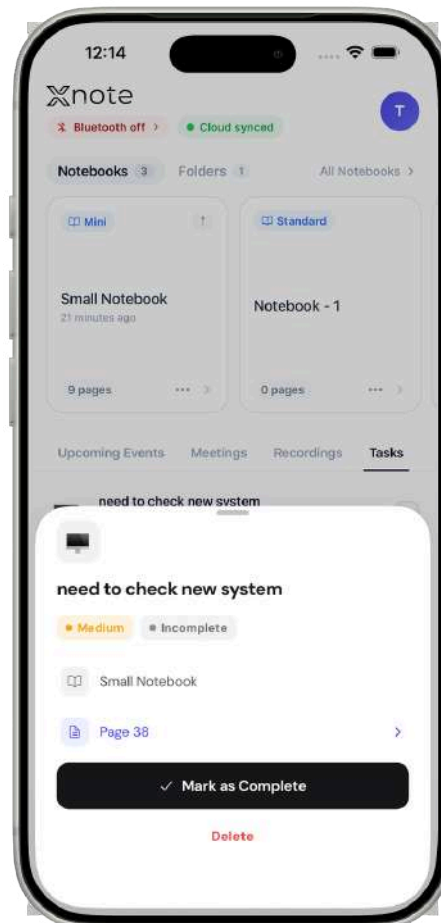

-Delete : Shows a confirmation dialog before removing the task

### 2.11.3 Sort & Search Tasks

Search: Use the search bar at the top to filter tasks by title (with a slight delay for smoother typing).

Sort: Tap the sort button to open the sort screen with the following options:

- Date created (newest / oldest)
- Task title (A-Z / Z-A)
- Due date (earliest / latest)
- Priority (high to low / low to high)

Active sort and filter indicators are shown on the respective buttons.

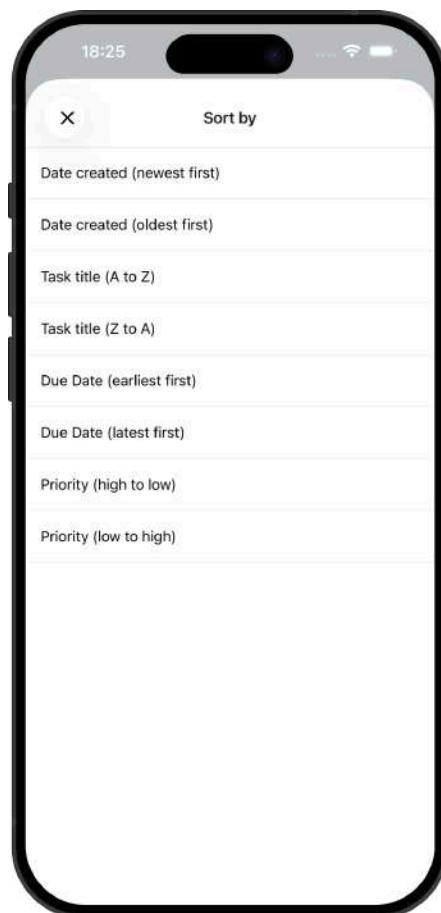

## 2.11.4 Todoist Integration

Connect your Todoist account to sync tasks from XNote to Todoist.

How to access: Go to Settings -> Integrations -> Todoist.

Setup:

1. Tap "**Connect Todoist**" on the Todoist welcome screen. An internet connection is required.

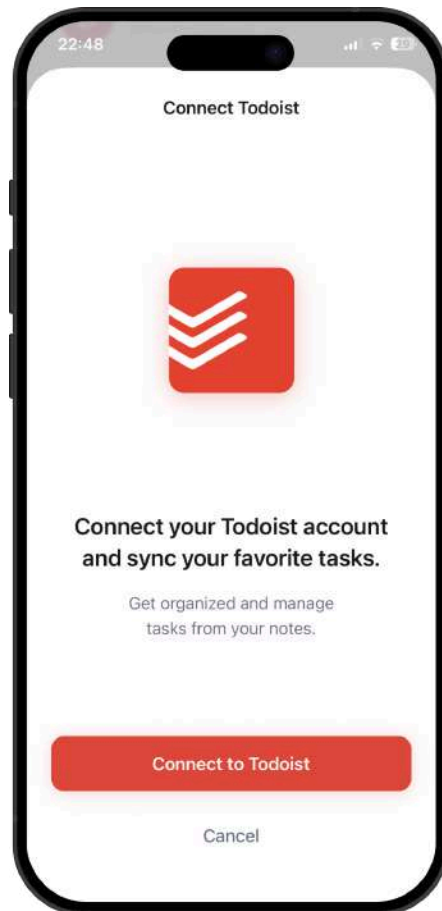

2. Sign in with your Todoist account in the browser and authorize XNote.

3. After successful connection, an onboarding screen shows three key features: Automatic Sync, Manual Control, and Note Integration. Tap **"Get Started"**.

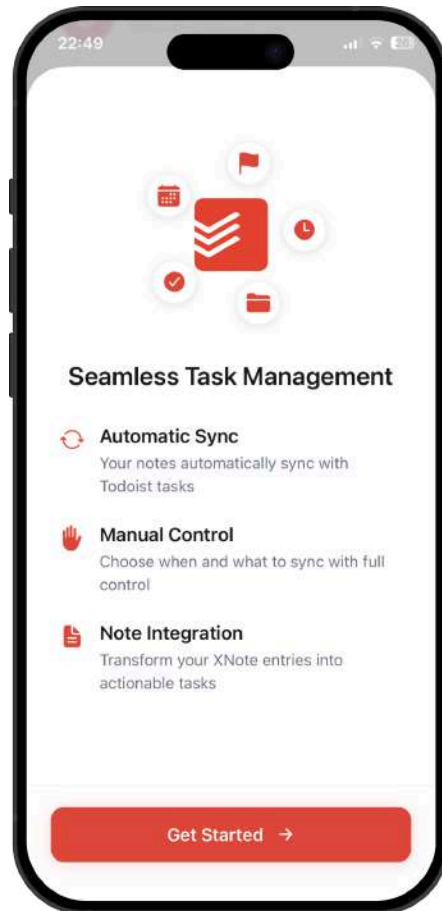

4. Configure your default Todoist settings:

- Sync Mode : Choose **"Auto"** (tasks are automatically sent to Todoist) or **"Manual"** (you manually send individual tasks).
- Workspace : Select which Todoist project to save tasks to.
- Priority : Set default priority P1 (Highest) to P4 (Low), each color-coded (P4 red, P3 orange, P2 blue, P1 white).
- Labels : Enter default labels (comma-separated, e.g., **"work, meeting"**).

5. Tap **"Save"** to complete setup.

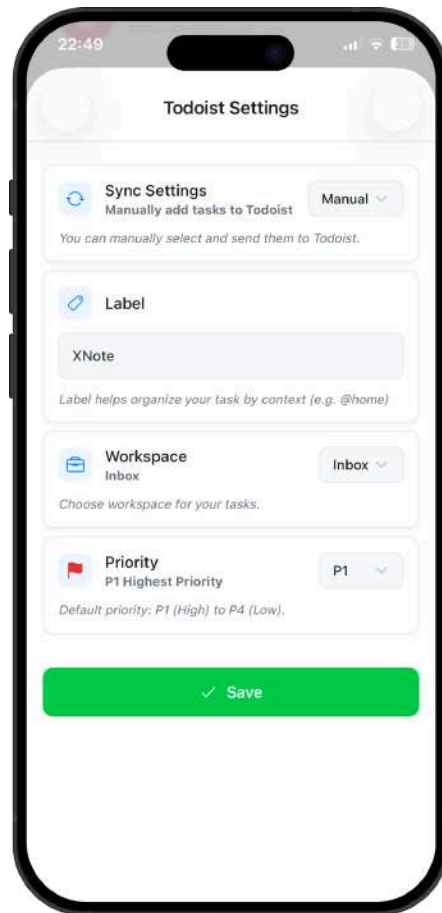

These default settings are applied when sending tasks from XNote to Todoist. You can change them anytime from Settings -> Integrations -> Todoist.

Sync a task to Todoist:

1. Open a task's detail sheet and tap **"Add to Todoist"**.

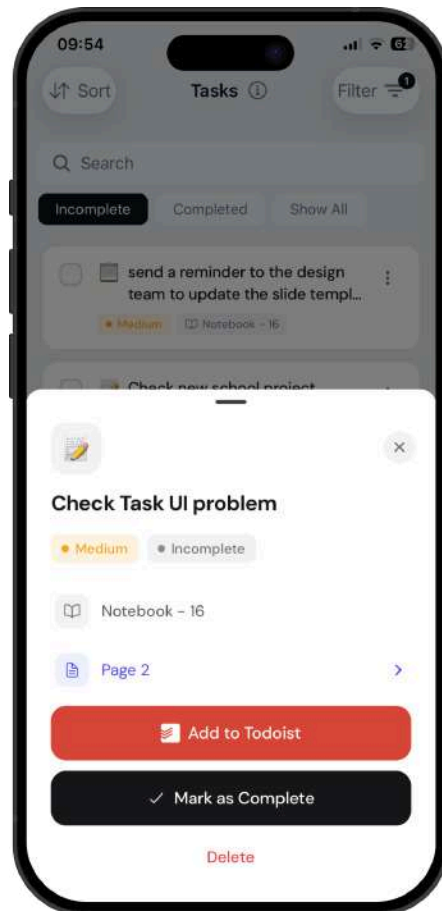

2. A **"Send to Todoist"** sheet opens where you can override the defaults for this specific task:

- Labels (text input)
- Workspace (dropdown)
- Priority (P1-P4 dropdown, with note: **"This priority level was detected by XNote AI. You can change it before sending."**)

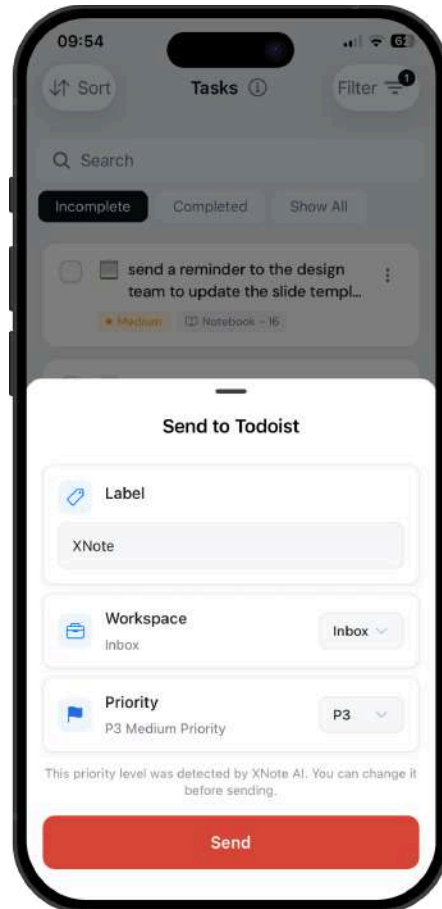

3. Tap **"Send"**. On success, the button turns green with **"Sent"** text and the sheet closes automatically.

Synced tasks show a small Todoist icon on the task row in the meta area (next to priority and due date). In the detail sheet, a **"View on Todoist"** link appears:

- On iOS/Android: Opens the task directly in the Todoist app if installed
- If the app is not installed: Opens the App Store or Play Store page for Todoist
- On macOS: Opens the task in the Todoist web app

Note: Sync is one-way (XNote to Todoist). Completing or uncompleting a task in XNote updates its status in Todoist, but changes made in Todoist are not synced back to XNote. Pull-to-refresh on the Tasks screen refreshes synced task statuses.

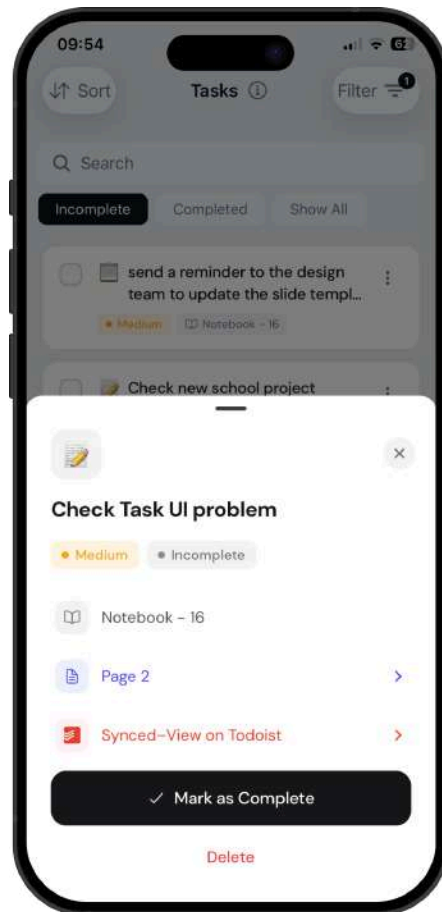

To disconnect: Go to Settings -> Integrations -> Todoist -> **"Disconnect Todoist"**. A confirmation dialog will ask: **"Are you sure you want to disconnect your Todoist account?"**

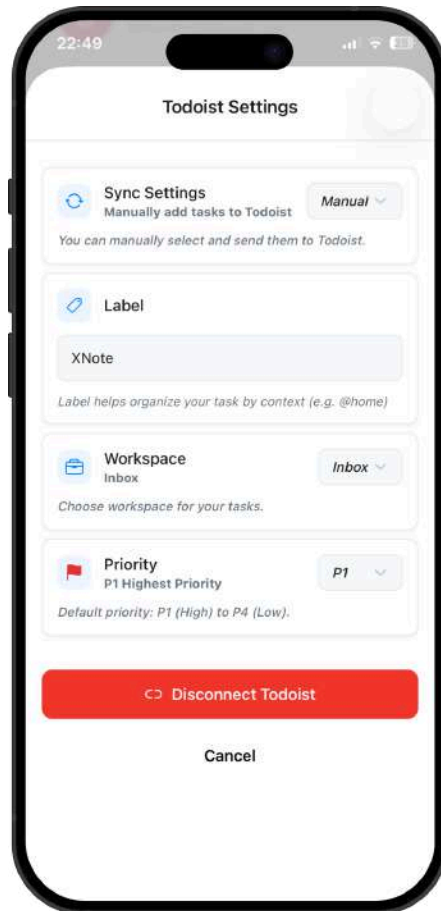

## 2.12 Events & Calendar

The Events tab shows your calendar events and lets you schedule recording bots for online meetings. Events can come from three sources: Google Calendar, your device calendar, and local events extracted from your notes.

Tap the **info** icon in the header to open the Events Help page a built-in guide explaining how XNote detects events from your handwriting, valid event formats (activity + date/time), timing examples (relative dates, specific times), and frequently asked questions.

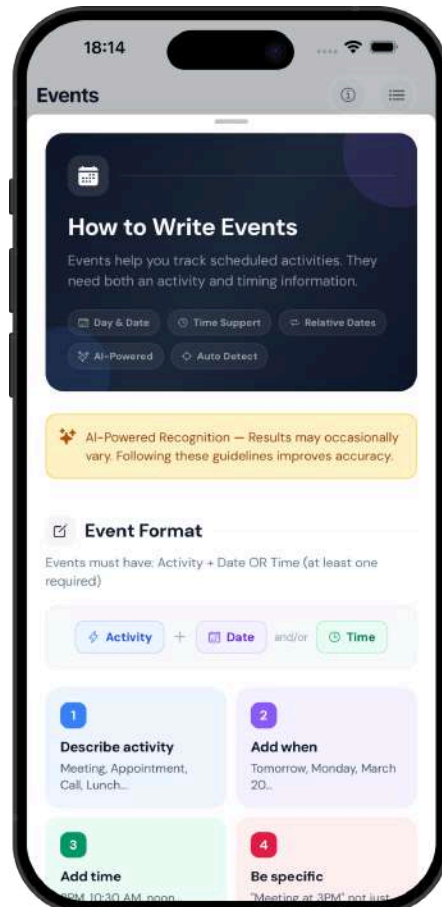

## 2.12.1 Calendar View & List View

Two views are available, toggled from the header icon:

Calendar View (default) : An expandable calendar showing the current month. Days with events show dot markers. Tap a date to see its events listed below. A **"Today"** button appears when viewing a different date.

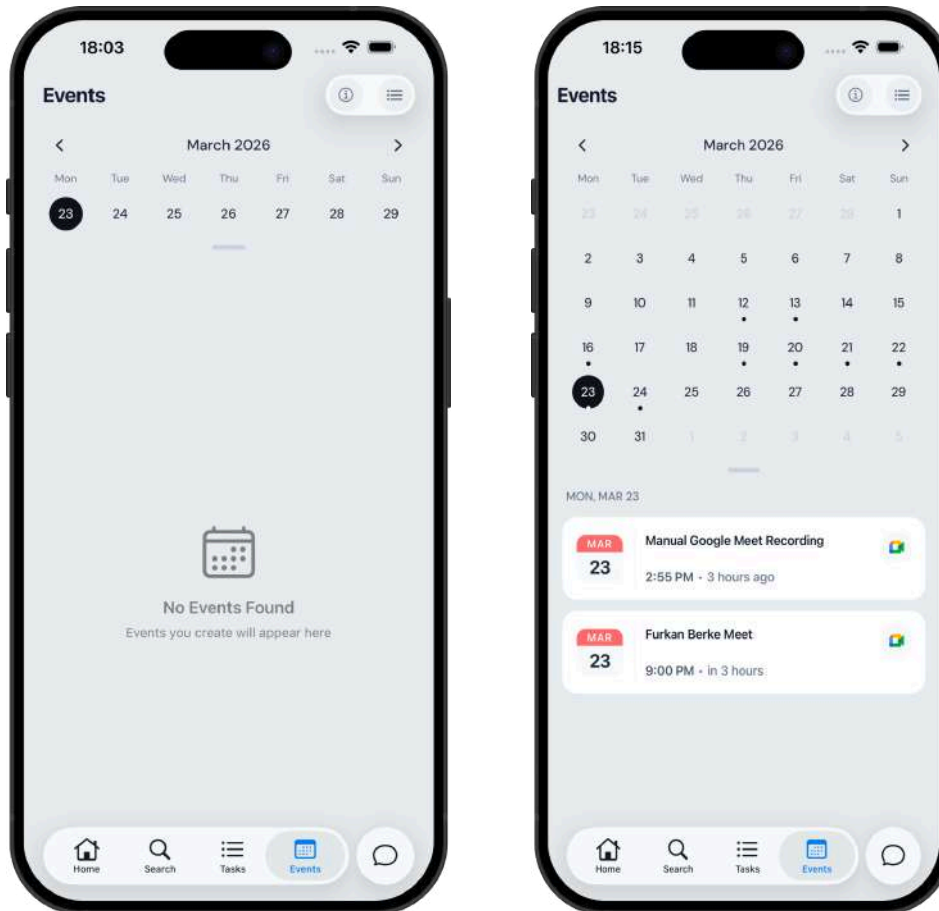

List View : All events listed chronologically, grouped by date sections. A sort button in the header lets you sort by:

- Event date (earliest / latest)
- Created date (newest / oldest)
- Title (A-Z / Z-A)
- Notebook (A-Z / Z-A)

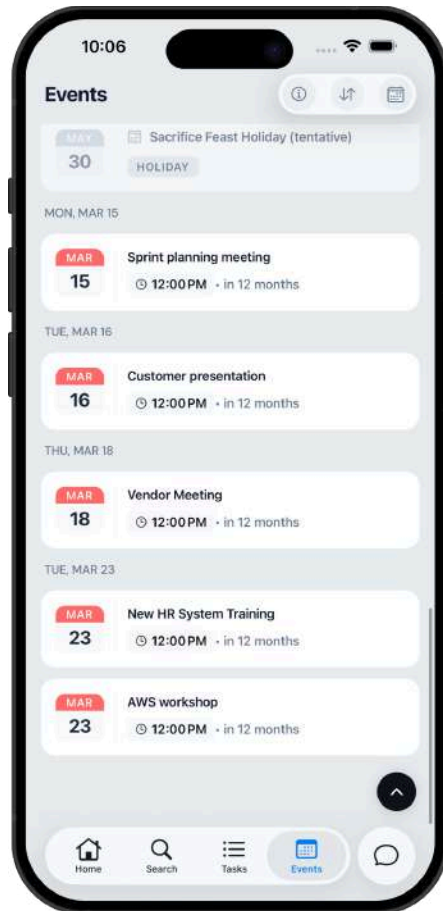

Filter: Tap the filter button to filter events by notebook or date status (Upcoming, Overdue, Today, No Date).

Each event card displays:

- Date box with month and day
- Event title
- Meeting provider logo (Google Meet, Zoom, Teams) for calendar events
- Time and relative countdown (e.g., **"in 2 hours"**)
- Recording bot status chip if a bot is scheduled or active ([see 2.12.4](#))
- Device calendar badge if the event also exists in your device calendar
- Google Calendar badge if a local event also exists in Google Calendar

There are three types of events:

- Meeting events : From Google Calendar, showing provider logo and meeting link
- Local events : Extracted from your notes, with options to add to device or Google Calendar
- Holiday events : Shown in a dimmed style with a **"Holiday"** badge

When no events exist, an empty state message is displayed.

## 2.12.2 Google Calendar Integration

Connect your Google Calendar to sync events and enable the Meeting Bot.

How to access: Go to Settings -> Calendar Settings -> Google tab. A **"Connect Google"** button is also available on the Event Detail screen ([see 2.12.3](#)) if no calendar is connected yet.

Setup:

1. Go to Settings -> Calendar Settings.
2. Tap **"Connect Google Calendar"**.

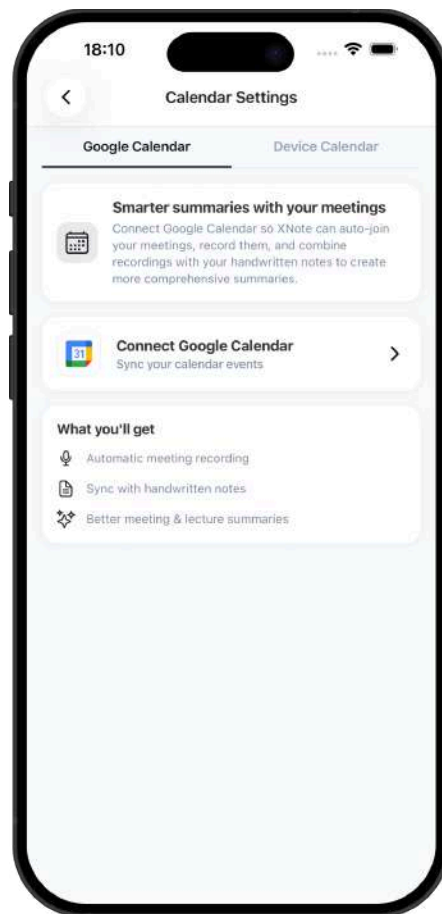

3. Sign in with your Google account and grant permission.

4. Select which calendars to sync. Your primary calendar is synced by default.

Events sync in near real-time via push notifications. You can connect multiple calendars and toggle each one on or off.

Calendar Settings has two tabs:

- Google tab: Manage Google Calendar connection, bot settings, and connected calendars list (showing calendar name, timezone, and primary badge).

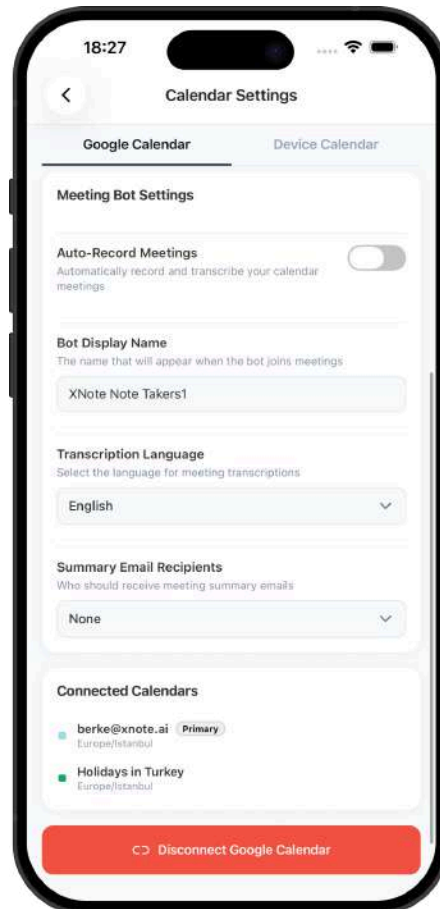

- Device tab: Manage device calendar permissions and select which device calendars to display.

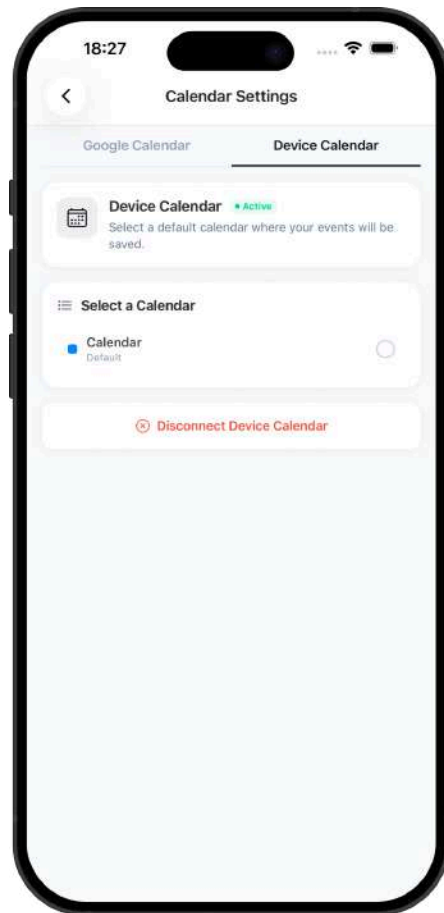

## 2.12.3 Event Details

Tap an event to view its details. The detail screen differs depending on the event source:

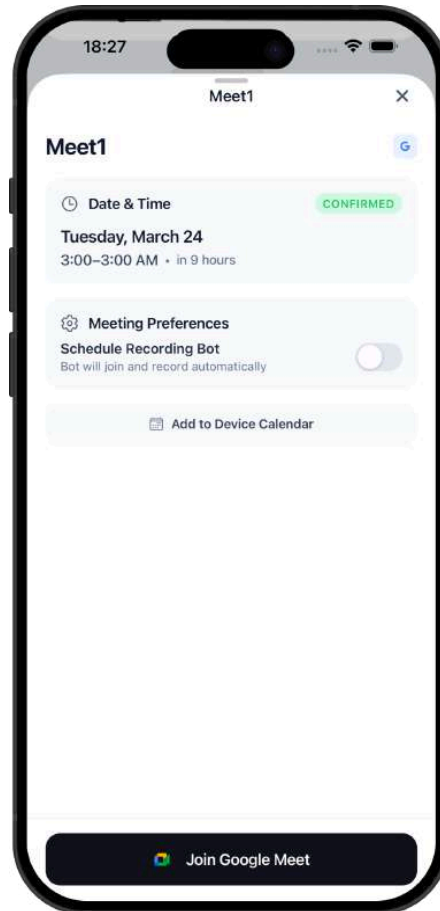

### Calendar Event Detail (Google Calendar events):

- Event title (read-only) and calendar source badge
- Date & time with relative countdown (e.g., "**in 5 minutes**")
- Status : Confirmed, Tentative, Cancelled, Live, Recording, Completed
- Attendees : Expandable list with response status (Accepted, Declined, Tentative, Pending). You are marked as "**You**" and shown first, followed by the organizer, then others alphabetically.
- Location (if set)
- Meeting link with provider logo (Zoom, Google Meet, Teams) and "**Join Meeting**" button
- Meeting Preferences section:
  - Auto-record toggle : Enable or disable recording for this specific event. Only shown when the event has a meeting link, is not cancelled, has not ended, and the bot is not already

active/finished. When enabled, a transcription language dropdown appears below to select the language for this recording ([see 2.12.4](#))

- Stop Bot button : If a bot is currently joining or recording, a stop button appears to cancel the bot.

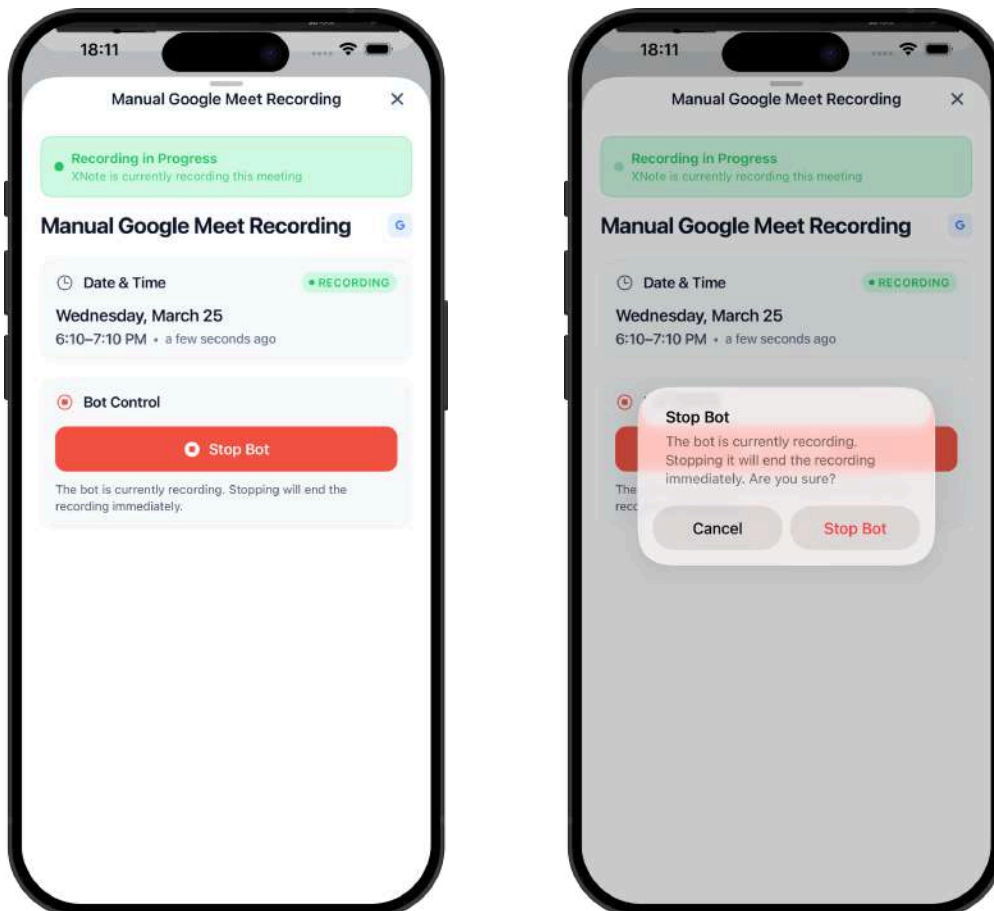

- Add to device calendar button : Add this event to your phone's native calendar. Shows a badge if already added.

- View Recording button : If a completed recording exists, tap to go to the audio session.

Note: Calendar event titles and details cannot be edited from within XNote. To edit them, use Google Calendar directly.

If Google Calendar is not connected, a **"Connect Google"** button will appear on this screen, allowing you to connect without leaving the event detail ([see 2.12.2](#)).

### Local Event Detail (events extracted from notes):

- Event emoji and title (read-only)
- Date & time (editable via date picker tap to change)
- Device calendar badge (if already added to device calendar)
- Google Calendar badge (if already added to Google Calendar)
- Source link : Shows the notebook and page where this event was extracted from. Tap to navigate to that page.
- Add to device calendar button : Creates the event in your phone's native calendar.
- Add to Google Calendar button : Creates the event in your connected Google Calendar. Only available if Google Calendar is connected.
- Connect Google Calendar button : If not connected, shown instead of the **"Add to Google"** button.
- Delete event button : Removes the local event. A confirmation dialog appears before deletion.

Note: Local event titles and emojis cannot be edited. They are generated by the AI from your note content.

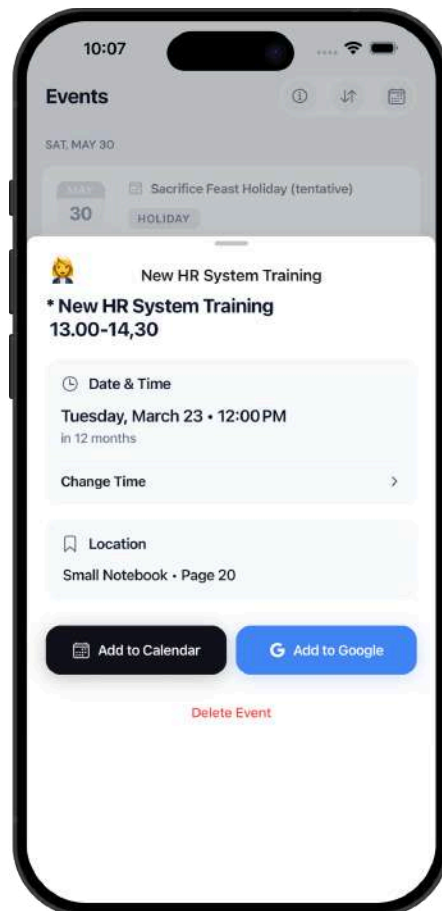

### **Recording Bot Status:**

If a recording bot was sent to a calendar event, a status banner shows the current state with real-time updates:

- Scheduled -> Joining -> Waiting for Host -> Waiting Room -> Recording -> Processing -> Completed

If the bot fails to join or is not admitted by the host within the timeout period, a failure status will appear with an error message.

Tap the "**View Recording**" banner after completion to go to the audio session.

## 2.12.4 Meeting Bot Scheduling

Schedule a bot to automatically join and record an upcoming meeting.

Per-event scheduling:

1. Open a calendar event with a meeting link ([see 2.12.3](#)).
2. Toggle the auto-record switch on.

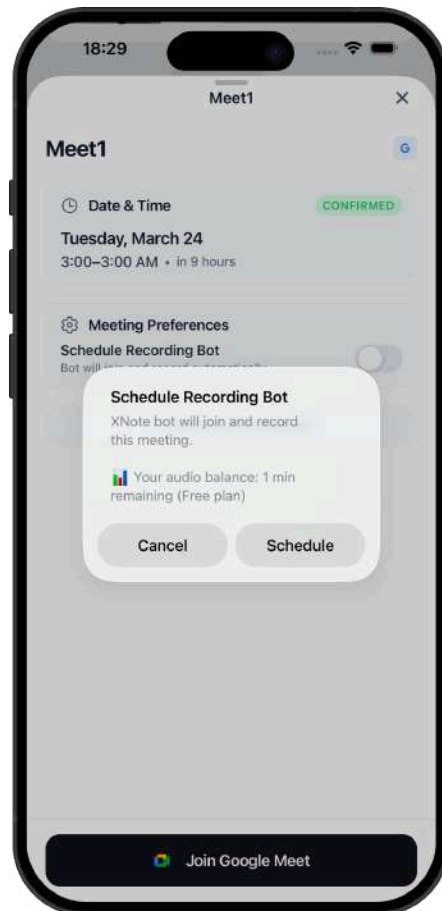

3. A confirmation shows your remaining audio minutes.

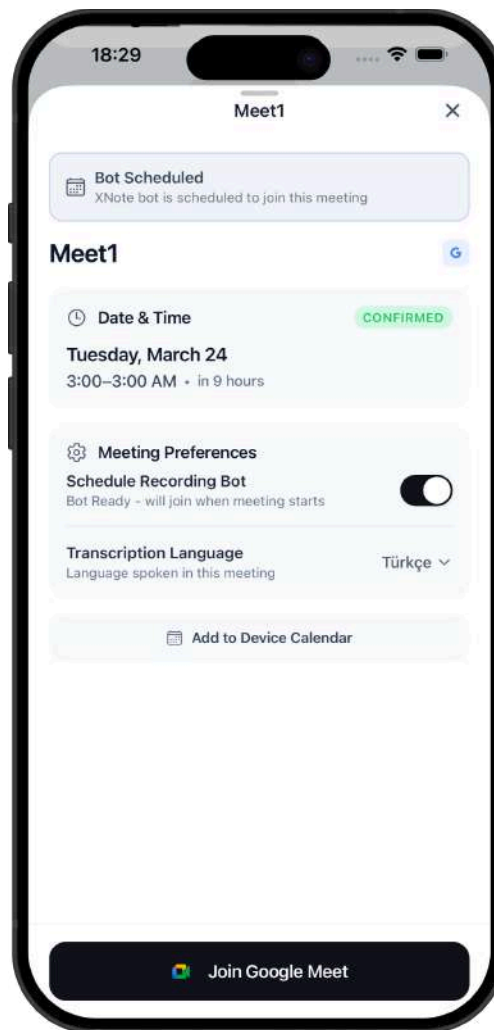

4. Select the transcription language (35+ languages, default: auto-detect).

The bot will automatically join when the meeting starts and begin recording.

You can also toggle auto-record directly from the Upcoming Events cards on the Home screen ([see 2.5.6](#)).

#### **Global auto-record:**

In Settings -> Calendar Settings -> Google tab, you can enable auto-record for all future events with meeting links. When enabled, every new event with a meeting link will have auto-record turned on by default. You can still override this per event.

Additional Calendar Settings available:

- Bot Display Name : Set a custom name for the bot shown in meetings (max 50 characters).
- Transcription Language : Set the default language for all recordings (35+ languages including auto-detect).

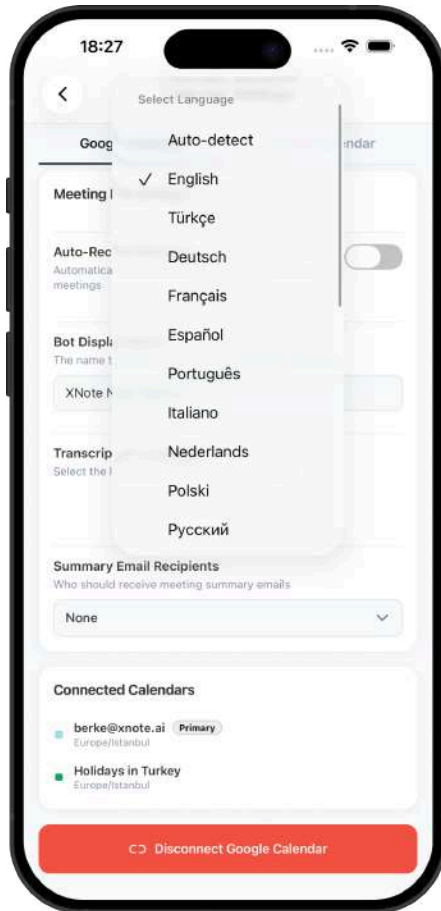

- Summary Email Recipients : Choose who receives the transcription summary email Only Me, All Attendees, or None.

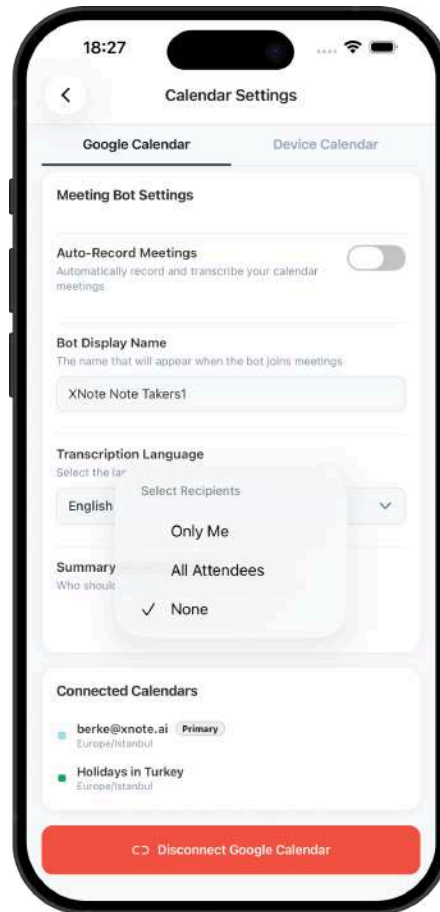

#### Limitations:

- Only one bot can record at a time per account.
- Scheduling is blocked if your audio minutes are exhausted.
- The bot will leave automatically if the host doesn't admit it within the timeout period.

## 2.13 Automations

Automations let you create rules that automatically perform actions when certain events occur in XNote.

Important: Automation availability depends on your plan ([see Section 4.1 for plan limits](#)).

### 2.13.1 View Automations

Go to Settings -> Automations to see all your automations in a 2-column grid. Each card shows:

- Automation name
- Description (1 line, truncated)
- Trigger type icon (flash for event-based, clock for time-based)
- Status indicator (green dot = Active, red dot = Inactive)
- First 2 action service icons (Gmail, Slack, Drive, etc.) with a "+N" indicator if more actions exist
- Three-dot menu for Edit, Delete, or Activate/Deactivate

Header actions:

- History button (clock icon) : View execution history ([see 2.13.6](#))
- Services button (link icon) : Manage connected services ([see 2.13.5](#))
- Three-dot menu : Bulk operations Activate All, Deactivate All, or Delete All

When activating automations, XNote checks your workflow quota. If your plan limit is reached, you will be prompted to upgrade or select which automations to keep active.

If you have no automations yet, the screen displays available templates to help you get started.

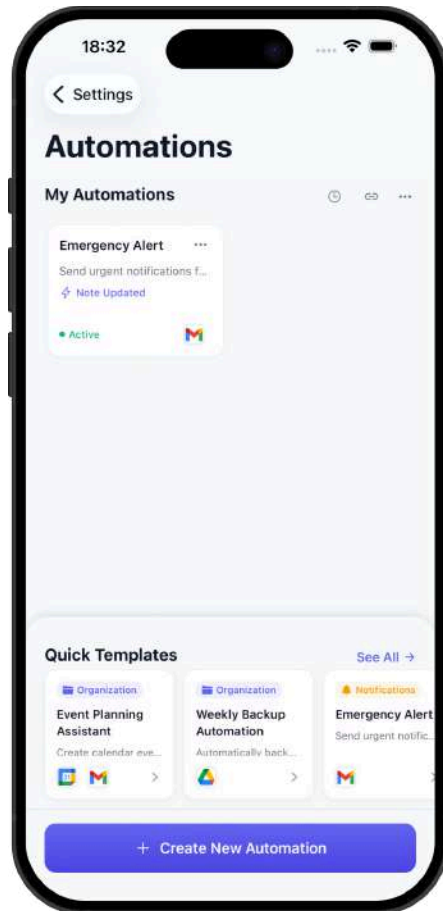

## 2.13.2 Create an Automation

Tap **"Create New Automation"** (gradient button at the bottom) to start a 5-step flow:

Step 1 : Basic Info:

Enter a name (required) and description (optional).

Step 2 : Trigger:

Choose what starts the automation:

- Note : When a note is updated. You can choose the trigger mode:
  - Every update : Fires on any change
  - New content only : Fires only when new content is added
- Task : When a task is created or completed
- Event : When a calendar event is created or updated
- Time : On a recurring schedule:

- Hourly : Runs every hour
- Daily : Runs at a specific time each day (time picker)
- Weekly : Runs on a specific day and time (day selector + time picker)
- Monthly : Runs on a specific day of the month and time (day 1-31 + time picker)

For time-based triggers, you must also select a notebook and content type (handwriting, text, or both).

Step 3 : Conditions:

Optionally add one or more conditions (connected with AND logic):

- Text contains a keyword (available for note, task, and event triggers)
- Task priority : Filter by high, medium, or low (task triggers only)
- No condition : Always execute (default)

Conditions are not available for time-based triggers.

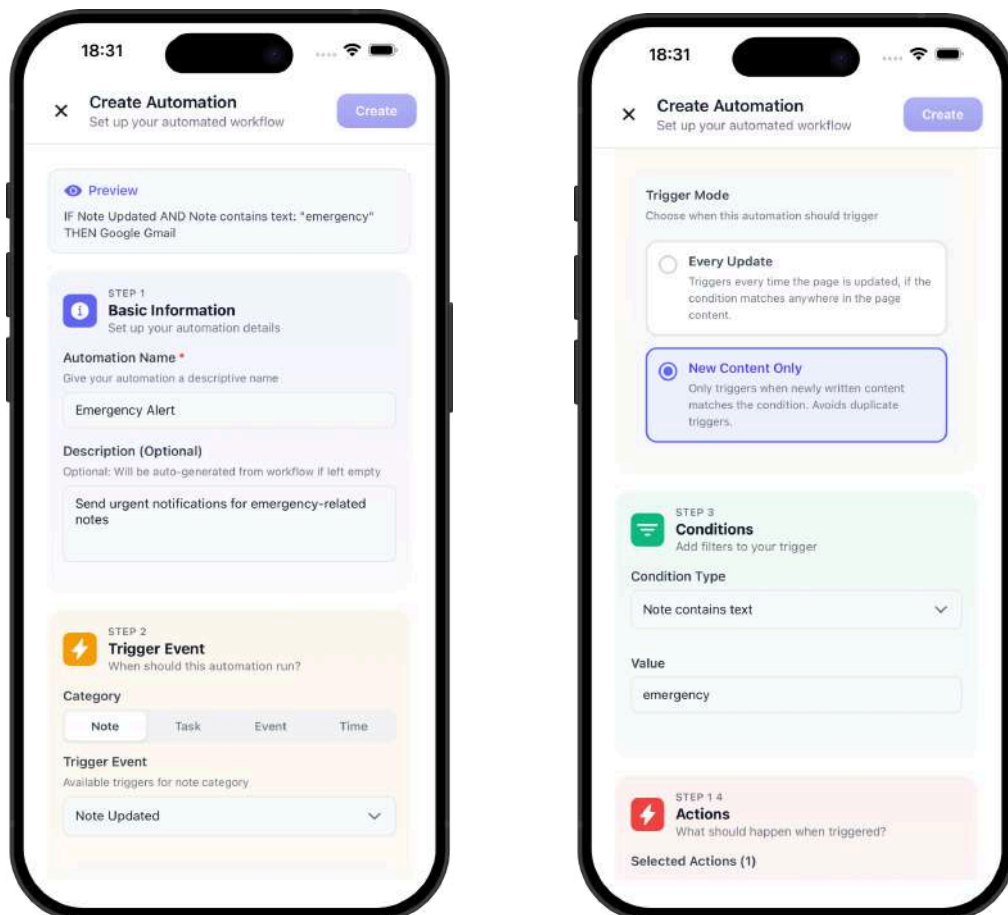

#### Step 4 : Actions:

Choose what happens when the automation fires (up to 10 actions):

- Gmail : Send an email

Configure: recipients (to, cc, bcc), subject and body (manual text, AI prompt, or auto-generated). You can use the {{content}} placeholder. A **"Test"** button lets you send a test email.

- Google Drive : Create or update a file

Configure: file name, file format (PDF, DOCX, TXT, HTML). Available for time-based triggers.

- Google Calendar : Create a calendar event

Configure: calendar selection, event summary (required), description.

- Google Tasks : Create a task

Configure: task list selection, task title, notes, due date.

- Slack : Send a message to a channel or DM

Configure: message content (manual, AI prompt, or auto), channel and/or user selection with search. You can use the {{content}} placeholder. A **"Test"** button lets you send a test message.

Each action shows its connection status. You must connect the service before configuring ([see 2.13.5](#)).

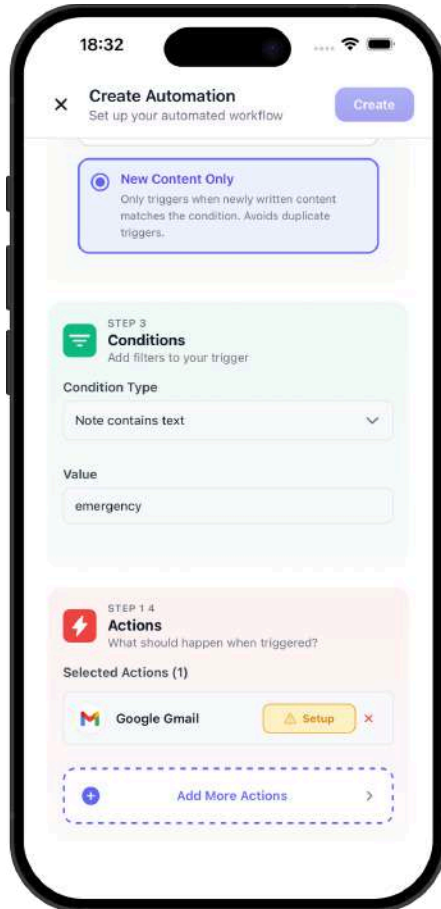

Step 5 : Review:

Review your automation settings before saving.

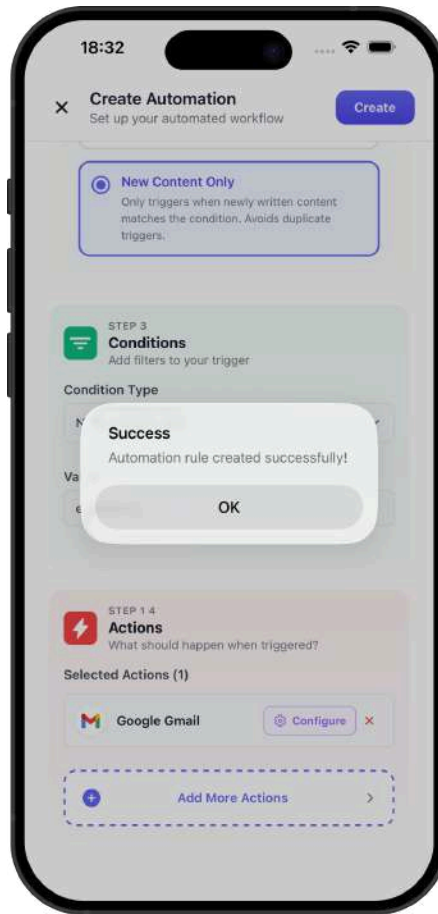
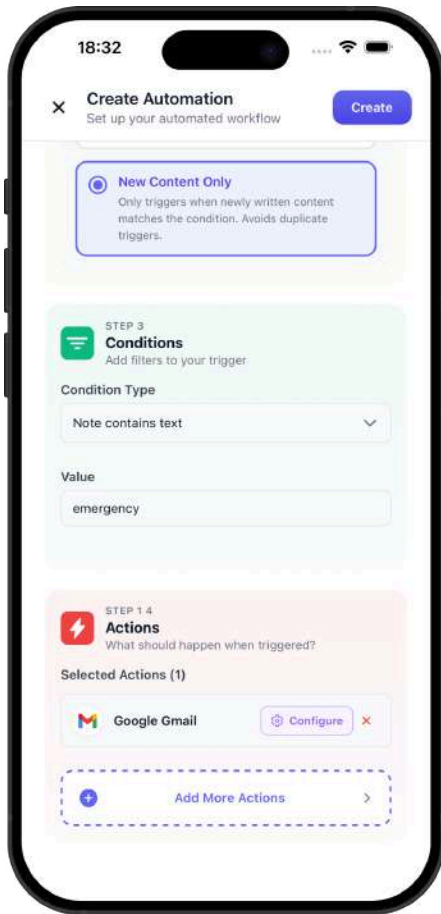

### 2.13.3 Edit an Automation

To edit an existing automation, tap the three-dot menu on its card and select **"Edit"**. The same 5-step flow opens with your current settings pre-filled.

You can change:

- Name and description
- Conditions and condition values
- Action configurations

You cannot change the trigger category (e.g., switching from a note trigger to a time-based trigger). If you need a different trigger type, create a new automation instead.

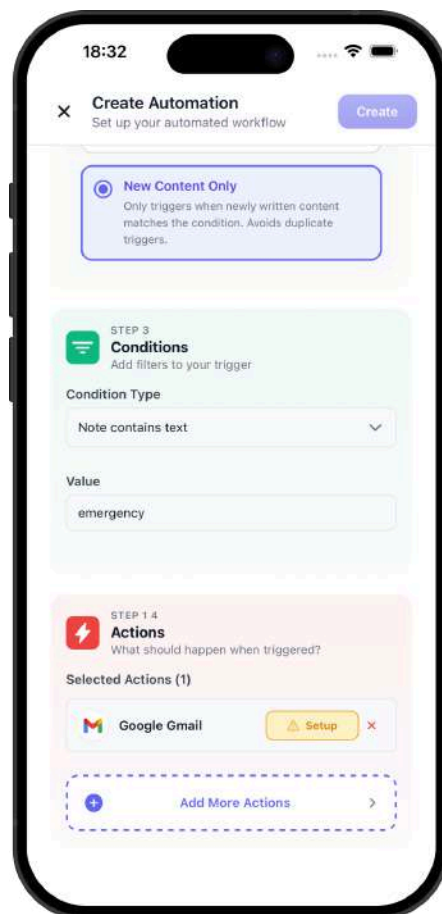

## 2.13.4 Automation Templates

XNote provides 23 pre-built templates to get started quickly. Templates are organized by category:

- Productivity (7 templates) : Task tracking, daily standup, brainstorm capture, etc.
- Notifications (7 templates) : Alerts, reminders, emergency notifications, etc.
- Organization (9 templates) : Backup automation, archive system, appointment tracking, etc.

Examples:

- Meeting Notes Sync : Sync notes to Google Drive after updates
- Emergency Alert : Send email when a note contains **"emergency"**
- Weekly Backup : Auto-backup notes to Drive every Monday
- Task Creation Tracker : Create Google Task + send Slack message on new tasks

Tap a template to pre-fill the creation form. You can customize all fields before saving.

Templates are shown on the main Automations screen (4 in a horizontal scroll with **"See All"** link) and on the dedicated Templates page (full 2-column grid with category filter tabs).

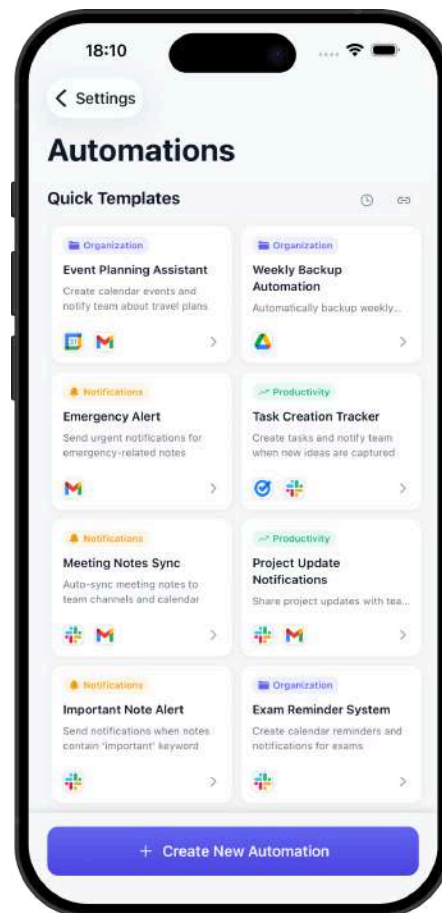

## 2.13.5 Connected Services (Google, Slack)

To use actions in automations, connect the required services first. Go to Settings → Automations → Services (link icon in header).

Available services:

- Gmail : Send emails
- Google Drive : Create/update files
- Google Calendar : Create/update events
- Google Tasks : Create/update tasks
- Slack : Send messages to channels or DMs

Each service card shows its connection status and the connected account name/email.

To connect a service:

1. Tap the service card.
2. Sign in and authorize XNote via OAuth in the browser.
3. The status will update to "Connected" with your account info.

To disconnect: Tap the service card again and confirm. If active automations depend on this service, a warning dialog will appear listing the affected automations by name and count. Disconnecting will deactivate those automations.

You can also disconnect all services at once from the menu.

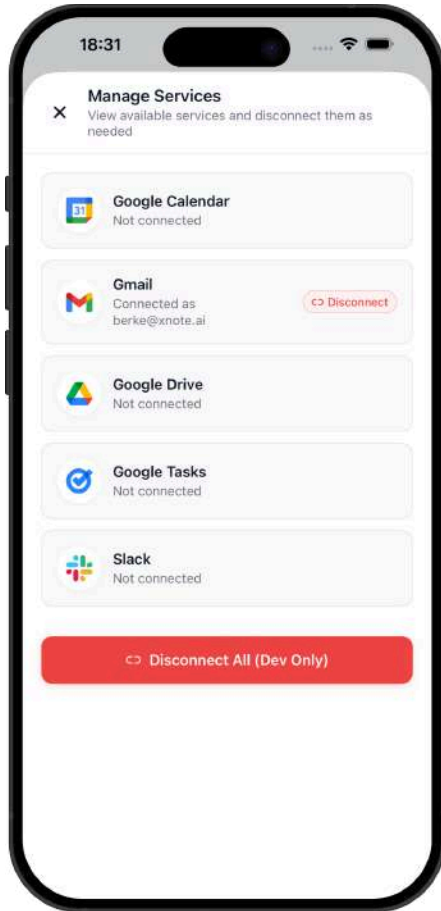

## 2.13.6 Automation History

Tap the clock icon in the Automations header to view execution history.

Each entry shows:

- Automation name
- Trigger event type (e.g., **"Note Updated"**, **"Task Created"**)
- Execution timestamp (formatted per your date format setting)
- Status icon : Pending (yellow), Completed (green checkmark), Failed (red X)
- Per-action results : Each action listed with its own status (pending, completed, or failed), start/completion time, and error message if failed

History is sorted with the most recent executions first.

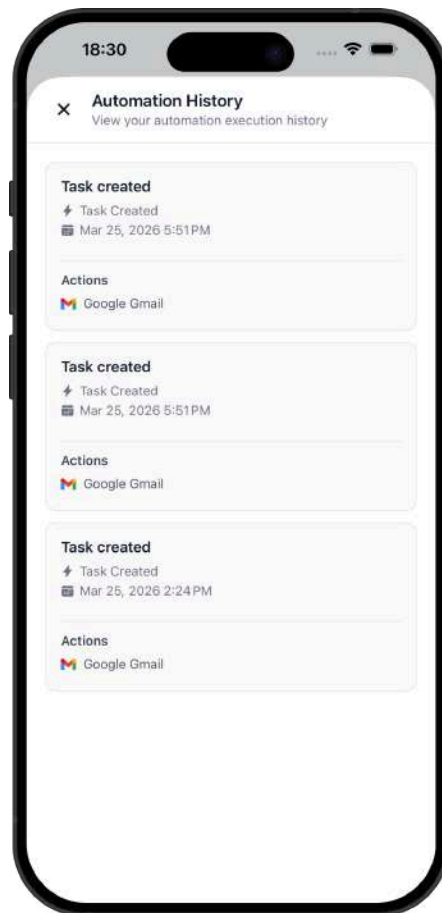

## 2.14 Folders & Tags

Folders and tags help you organize your pages across notebooks.

### 2.14.1 Create & Manage Folders

Create a Folder:

A folder can be created from multiple places:

- From the Home screen: Tap **"+ Create Folder"** in the Folders tab.
- From the All Folders screen: Tap the **"+"** button in the header.
- From the Add to Folder sheet: When adding a page to a folder, tap **"Create New Folder"** at the bottom of the folder list to create one inline without leaving the current flow.

When creating a folder:

1. Enter a folder name (max 25 characters).
2. Select an emoji (default: folder icon). Tap the emoji to open the picker.
3. Tap **"Create Folder"**.

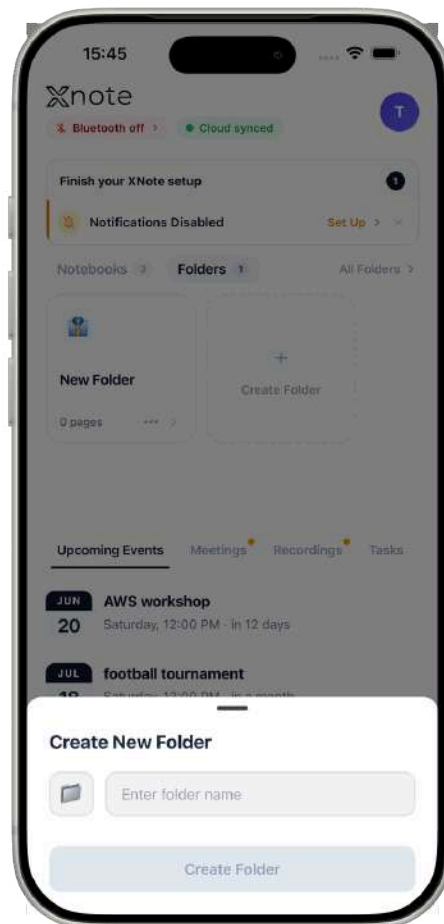

## Rename or Change Emoji:

Tap the three-dot menu on a folder card -> the folder settings sheet opens. Tap the name to edit it or tap the emoji to change it. Changes are saved automatically.

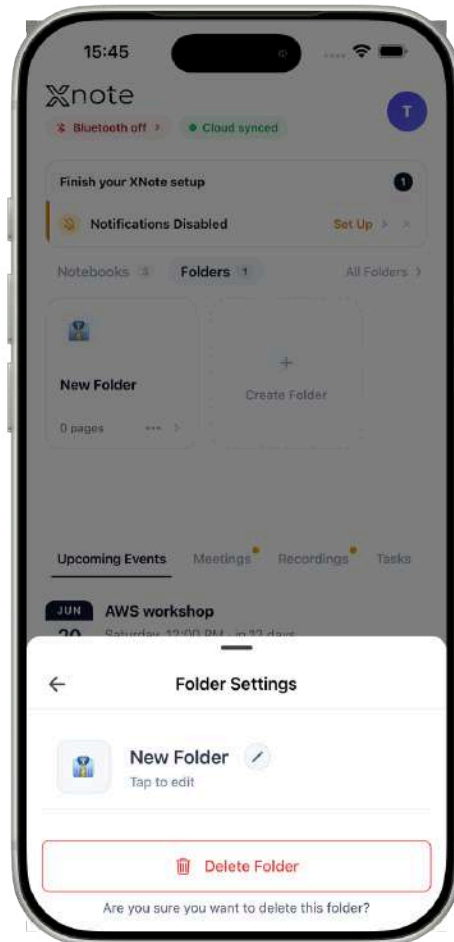

## Delete a Folder:

In the folder settings sheet, tap **"Delete Folder"** and confirm in the dialog. Deleting a folder removes all page associations but does not delete the pages themselves they remain in their original notebooks.

## 2.14.2 View All Folders

Tap "**See All**" in the Home screen Folders tab to open the All Folders screen.

All your folders are displayed in a grid layout. Each folder card shows:

- Folder emoji
- Folder name
- Page count
- Three-dot menu for settings

You can search folders by name using the search bar at the top. Sort folders by:

- Name
- Page count
- Creation date
- Ascending or descending order

Tap a folder to view its pages ([see 2.14.3](#)). Tap the three-dot menu to rename, change emoji, or delete the folder.

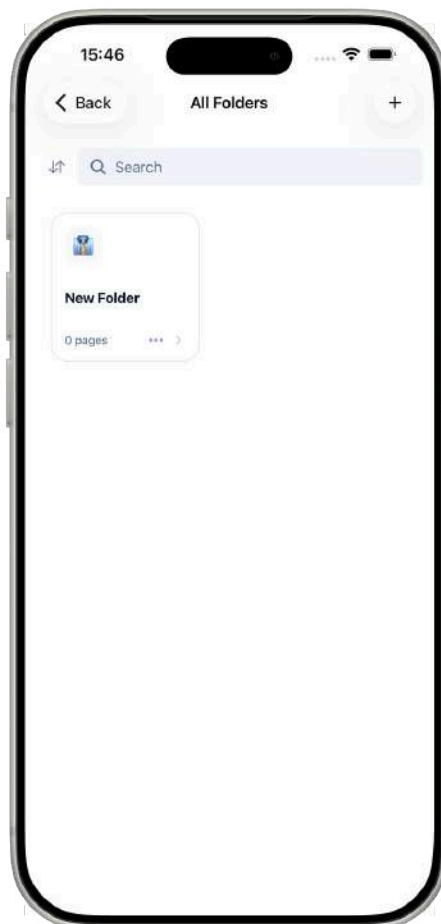

## 2.14.3 Folder Detail (View Pages in a Folder)

Tap a folder to view all pages inside it. Pages from different notebooks can appear in the same folder.

Each page shows:

- Page thumbnail (handwriting preview)
- Page number and notebook name
- X button to remove the page from this folder

You can sort pages by page number or last edited date. Long-press a page to enter selection mode for bulk export.

To remove a page from a folder, tap the X button on its thumbnail and confirm.



## 2.14.4 Add Pages to Folders

You can add a page to a folder in two ways:

- From the page grid: Tap the folder icon on any page thumbnail that is not already in a folder. The **"Add to Folder"** sheet will open.
- From the header tab menu: Tap the folder icon.

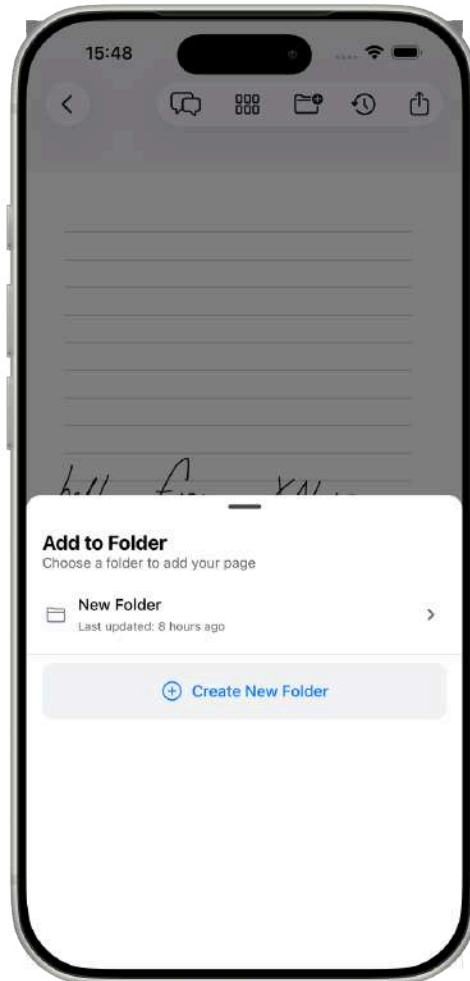

In the Add to Folder sheet:

1. Your existing folders are listed with their emoji, name, and last updated date.
2. Folders that already contain this page show an **"Already added"** label.
3. Tap a folder to add the page to it.
4. To create a new folder from here, tap **"Create New Folder"** at the bottom of the list.

Pages from different notebooks can be added to the same folder. A page can belong to multiple folders.

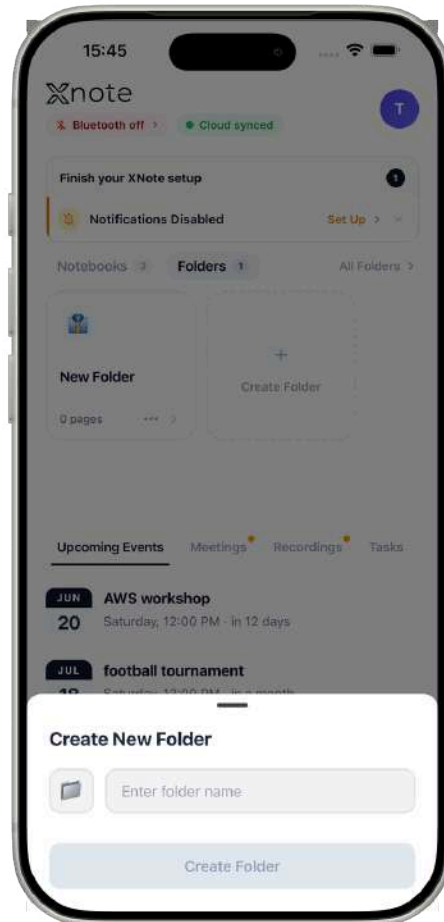

## 2.14.5 Create & Manage Tags

How to access: From the Search screen, tap **"Manage"** in the Tags section. You can also reach it via **"See All Tags"** -> **"Manage"**.

### Create a Tag:

1. Enter a tag name (2-50 characters, alphanumeric and underscores only).
2. Select a color from 12 preset options: Red, Teal, Blue, Salmon, Mint, Yellow, Purple, Sky Blue, Orange, Green, Pink, Amber.
3. Tap **"Create Tag"**.

Duplicate tag names (case-sensitive) are not allowed.

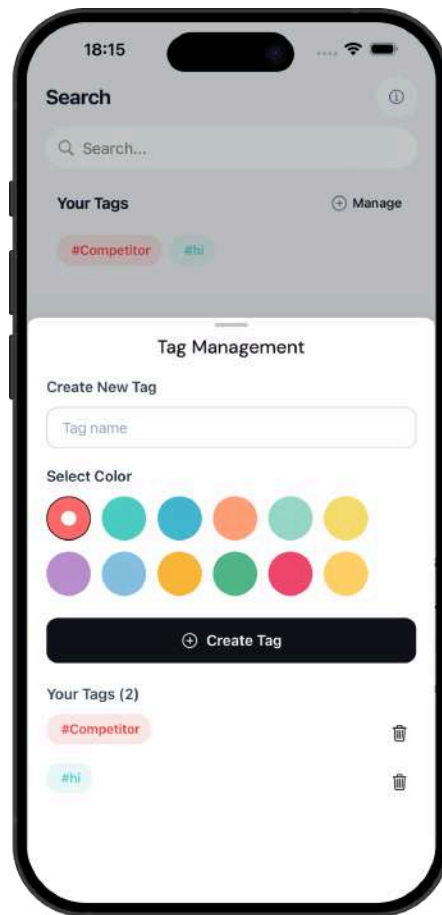

### Edit a Tag:

Tap an existing tag in the **"Your Tags"** list. The form switches to edit mode, populating with the tag's current name and color. Modify and tap **"Update"**. Tap **"Cancel"** to discard changes.

### Delete a Tag:

Tap the trash icon next to a tag. A confirmation dialog will appear before the tag is removed.

All your existing tags are displayed below the create/edit form with a total count in the section title.

## 2.14.6 Tag Pages

1. Navigate to the Page Tag Management screen for a specific page.
2. All your tags are displayed as selectable chips. Tap a tag to apply it a checkmark animation appears and the chip highlights.

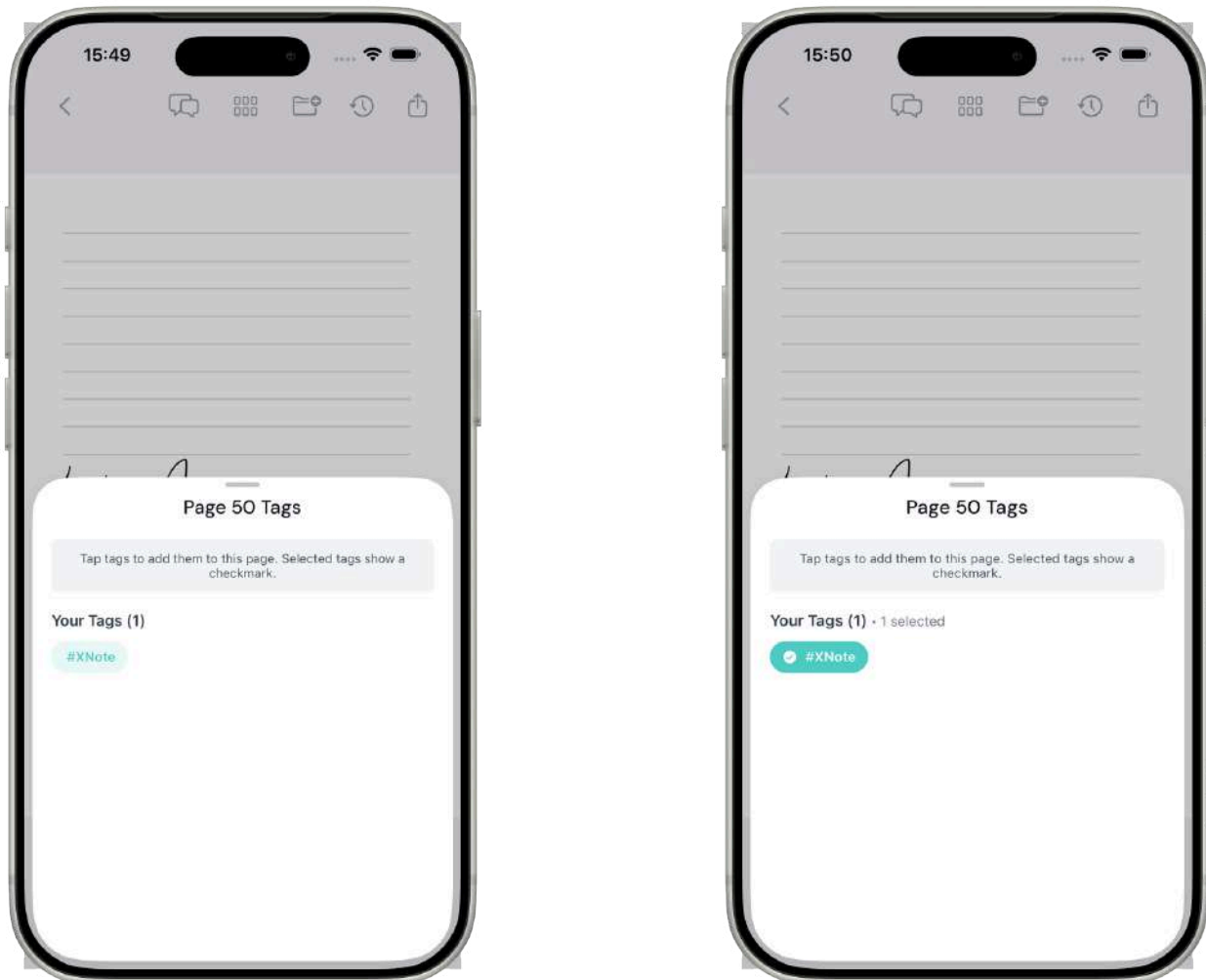

3. Tap again to remove the tag.

If you have no tags yet, a **"Create Tag"** button is shown that navigates to the Tag Management screen [\(see 2.14.5\)](#).

A page can have multiple tags. Tagged pages can be found through tag-based filtering in the Search tab [\(see 2.10.3\)](#).

## 2.15 Share & Export

Share your pages and recordings via public links, or export pages in multiple formats.

## 2.15.1 Share a Page (Link)

1. Open a page and tap the Share option.
2. Select an expiration period: 7 days, 30 days, or Never.
3. Tap **"Create Link"**.

A public link is generated (e.g., <https://web.xnote.ai/share/...>). Anyone with the link can view the page : no login required.

Tap Copy to copy the link or use the system share sheet to send it via any app.

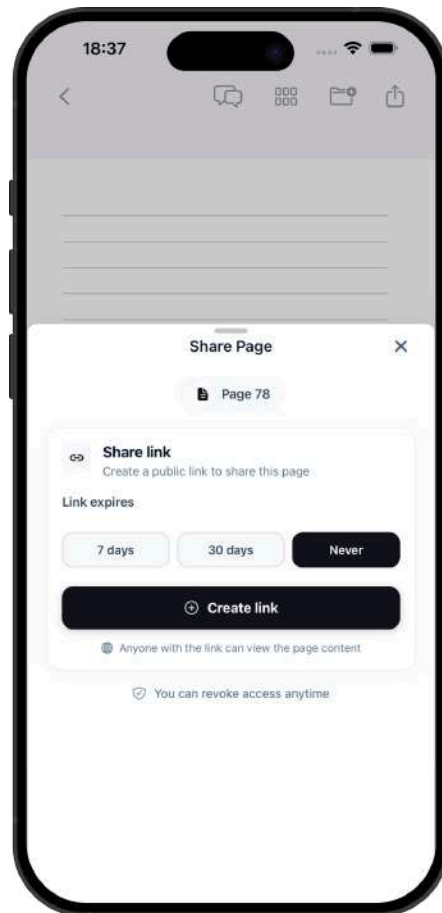

## 2.15.2 Share a Recording (Link)

1. Open an audio session and tap Share.
2. Select an expiration: 1 day, 7 days, or Never.
3. Choose who to notify by email: All attendees, Only me, or None.

#### 4. Tap **"Create Link"**.

The shared link includes the AI-generated summary and meeting metadata. The actual audio file remains private and is not included.

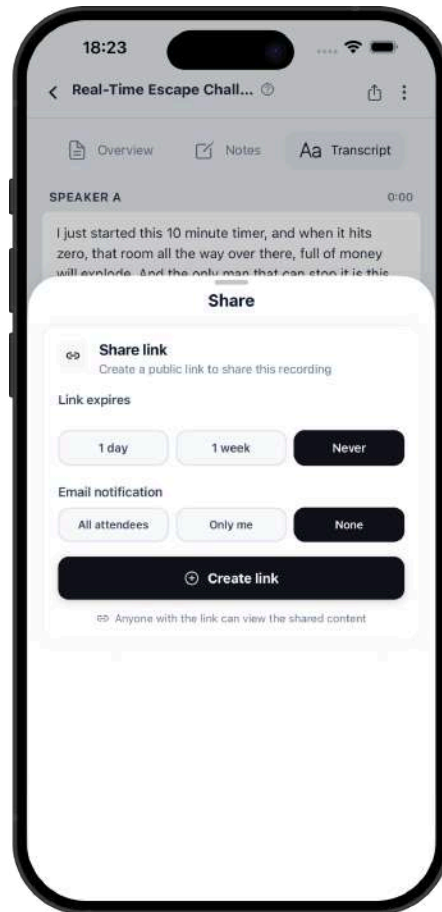

### 2.15.3 Manage Shares

To view or revoke an existing share:

1. Open the page or recording's share screen.
2. If a link already exists, it will be displayed with its expiration date.
3. Tap **"Revoke"** to immediately disable the link.

There is no centralized dashboard for all shares : shares are managed per page or per recording.

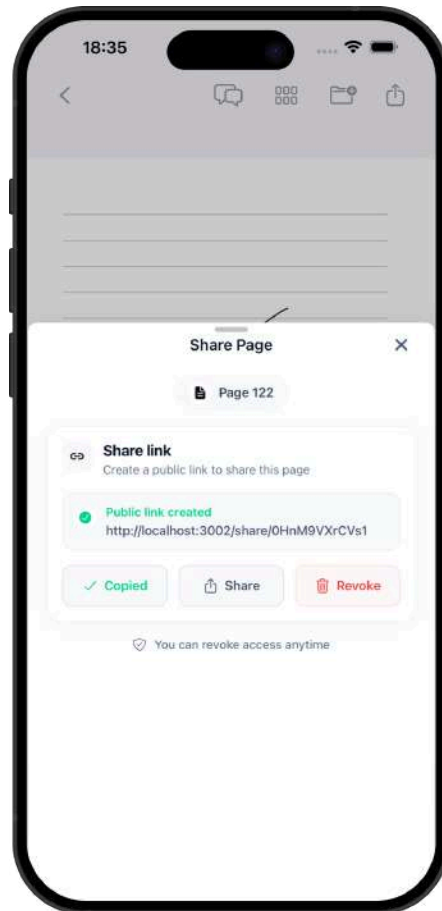

## 2.15.4 Export a Notebook

You can export an entire notebook as a single PDF from the notebook card's three-dot menu.

1. Tap the three-dot menu on any notebook card (Home screen or All Notebooks screen).
2. Tap **"Share"** in the notebook settings sheet.
3. A PDF of the entire notebook is generated (a loading indicator shows **"Exporting..."**).

4. The native share sheet opens, allowing you to save the file, send via email, AirDrop, or any other app.

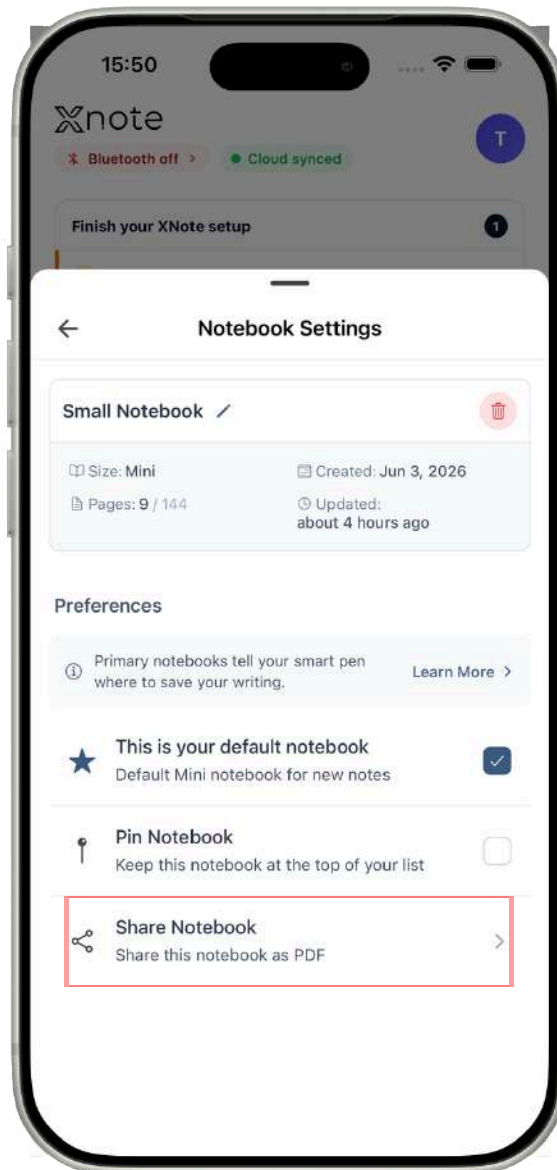

### 2.15.5 Export Pages (PDF, PNG, SVG, DOCX, Markdown)

Open a page and tap the Export button in the header toolbar. Two views are available:

Quick Export (default view):

Two one-tap options for the current page:

- Handwriting PDF : Exports your original handwriting as a PDF document.

- Digital Text Word : Exports OCR text as a DOCX Word document.

Additional quick actions:

- Share Page : Creates a public shareable link (requires internet, [see 2.15.1](#)).
- Multiple Pages : Opens the page grid in selection mode for bulk export ([see 2.15.6](#)).
- All Export Options : Enters the advanced export view.

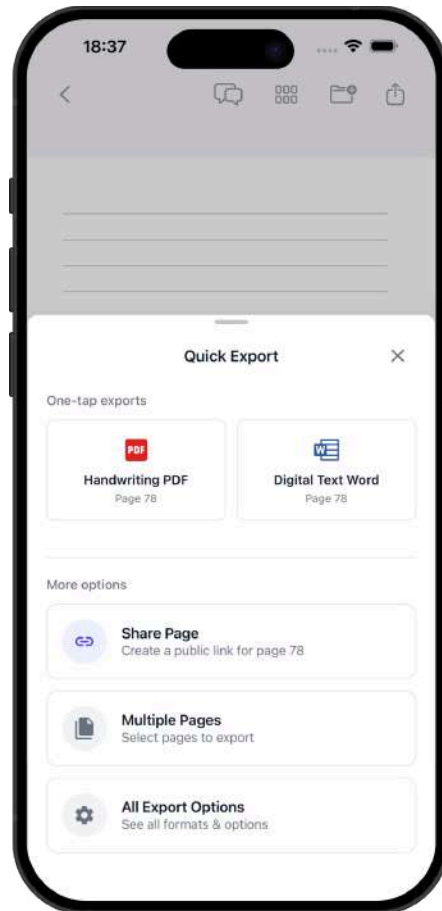

Advanced Export (All Export Options):

First choose a content type:

- Handwriting : Export as drawn strokes / images.
- Digital Text : Export as text content.

Then choose a format:

Handwriting formats:

- PDF : Handwriting (strokes)
- PNG : Handwriting as high-res image
- SVG : Handwriting as scalable vector

Digital Text formats:

- PDF : Text-only PDF
- DOCX : Word document
- Markdown : Plain text markdown

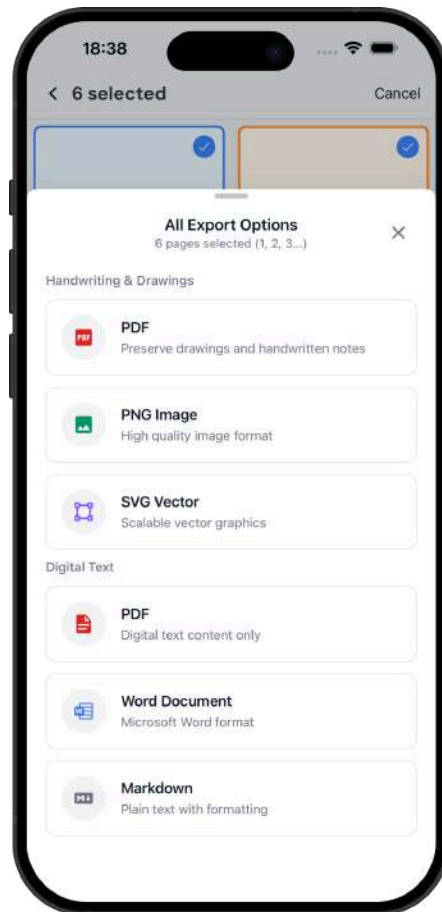

You can toggle "Show notebook background" on or off for handwriting exports (PDF and PNG). When off, the exported file has a clean white background.

After the file is generated, a loading modal shows "Exporting Pages Please wait while we prepare your files...". Once ready, the native share sheet opens automatically.

## 2.15.6 Bulk Export (Multiple Pages)

To export multiple pages at once:

1. From the page detail export screen, tap **"Multiple Pages"**. This opens the page grid in selection mode.

Alternatively, long-press a page in the page grid to enter selection mode directly.

2. Tap pages to select them a checkmark appears on each selected page.

3. Tap **"Export"** in the bottom action bar.

4. Choose content type (Handwriting or Digital Text) and format.

The export screen shows: **"X pages selected (1, 3, 5...)"** with the selected page numbers.

For multi-file formats (PNG, SVG), a ZIP archive is created automatically. For text-based formats (DOCX, Markdown), all pages are combined into a single document with page breaks.

Note: Bulk export works within a single notebook. All selected pages must be from the same notebook.



## 2.16 Offline Sync

Sync handwritten notes from your XNote Pen to the app via Bluetooth. When you write with your pen, the strokes are stored on the pen's internal memory. Use Offline Sync to transfer them to the app and save them to your notebooks.

### 2.16.1 Home Screen Sync Banner

When unsynced data exists on your pen or in the app's local cache, a banner appears at the top of the Home screen:

- If pen is connected: **"You have unsaved writings Ready to sync your pen and save your notes"**

- If cache only (pen not connected): **"You have unsaved notes ready to organize"**

Tap the **"Import"** button on the banner to open the Offline Sync screen.

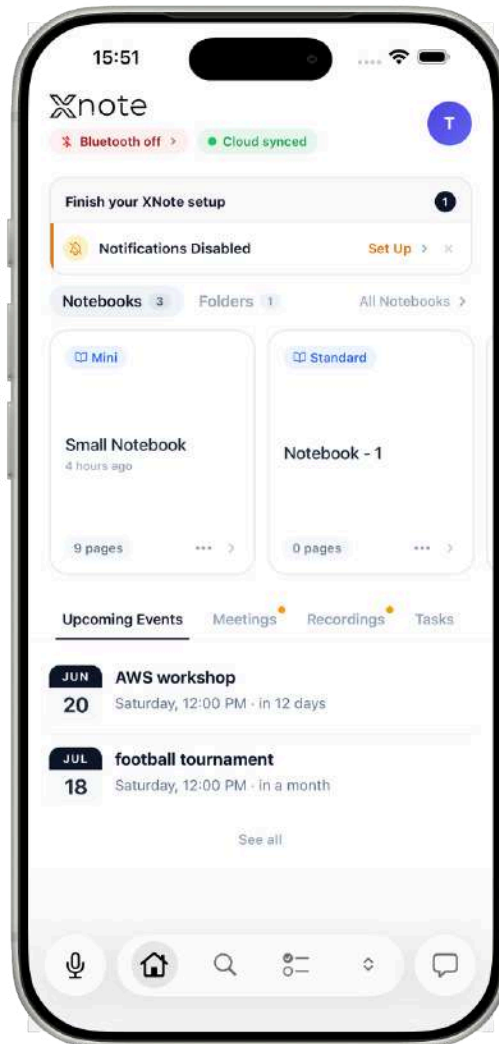

## 2.16.2 Sync from Pen

How to access: Tap the **"Import"** button on the Home screen sync banner, or navigate to the Offline Sync screen directly.

The Offline Sync screen shows:

- Pen connection status at the top (connected/disconnected indicator)
- Collapsible 3-step instructions for first-time users
- A list of notebooks with unsynced pages, combining data from both the pen and the local cache

Each notebook item shows:

- Notebook thumbnail image
- Notebook type badge (Mini / Standard / Large)

- Number of pages written
- Tap to view pages, or **"See All Pages"** button

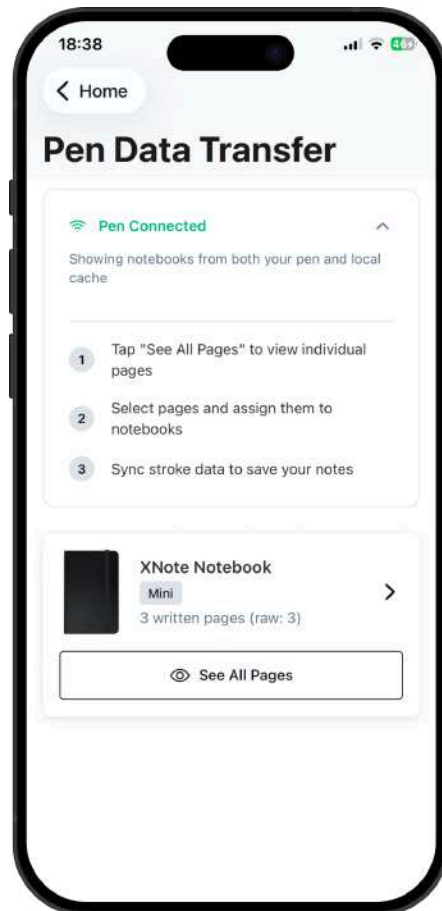

Step-by-step sync process:

1. Make sure your pen is connected via Bluetooth.
2. Tap a notebook to view its pages. XNote retrieves the page data from the pen a progress bar shows the retrieval progress. Keep the app open and the pen nearby during this process.

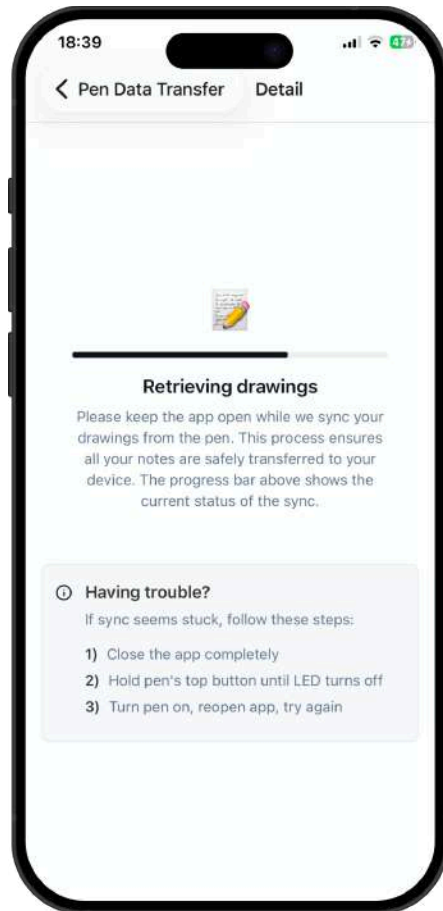

3. Each page shows a thumbnail preview, page number, and stroke count. Pages are automatically assigned to your primary notebook of the matching size.

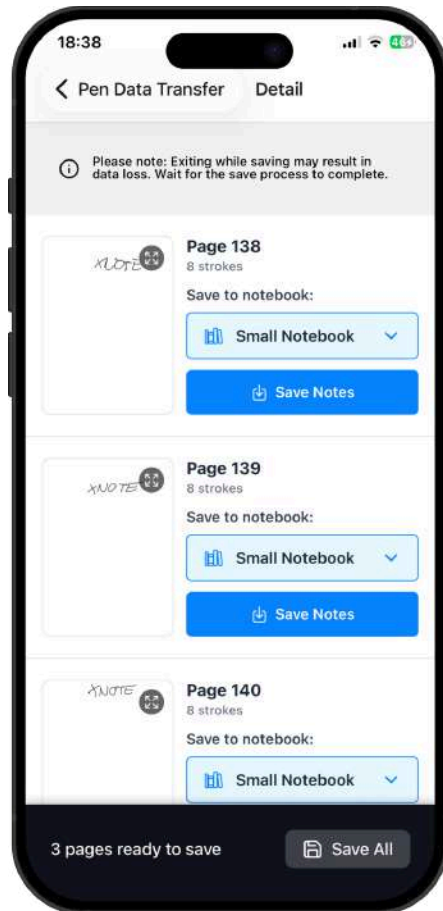

4. To change the target notebook for a specific page, tap the notebook selector and choose a different notebook from the list. You can also create a new notebook from here ([see 2.6.2](#)).

5. Tap "**Save Notes**" on individual pages, or use the batch save to save all pages at once.

Sync is a manual process you choose when and which pages to transfer. After saving, pen data is automatically deleted from the pen's memory.

If no notebook of the matching size exists, XNote will prompt you to create one before proceeding ([see 2.6.2](#)).

### 2.16.3 Sync Progress & Results

During save, a progress bar at the bottom shows the batch progress:

- Text displays: **"Saving X of Y pages"**
- Green progress bar fills as each page is saved

After completion, a summary alert shows the result:

- All saved successfully: **"X pages saved"**
- Partial success: **"X saved, Y failed"**
- All failed: **"No pages saved"**

Saved pages show a green checkmark overlay on their thumbnail.

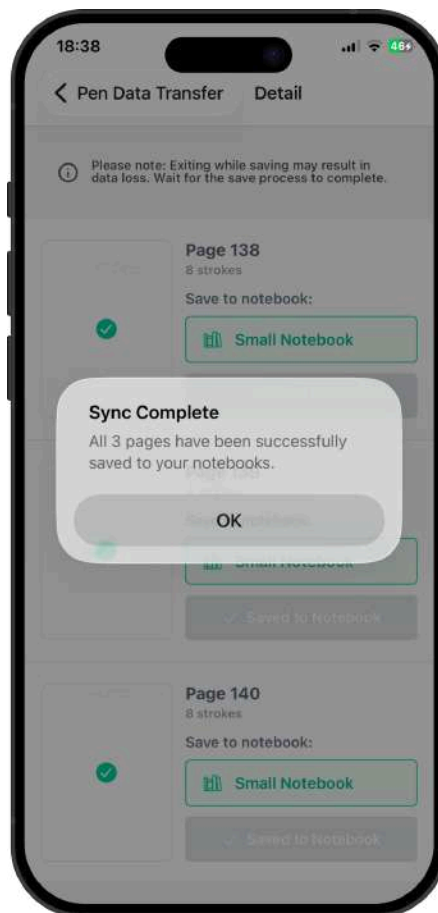
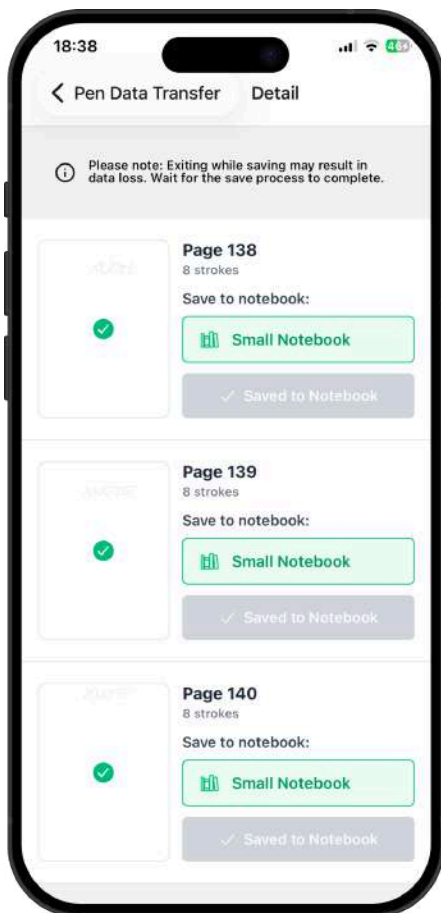

## 2.16.4 Sync Status

To view your overall data sync status (PowerSync cloud sync, not pen sync), tap the sync status chip on the Home screen or go to Settings -> Sync Status.

The screen shows 6 status indicators:

1. Internet Connection : Green (connected) or Red (disconnected)
2. PowerSync Server : Green (connected), Yellow (connecting), or Red (disconnected)
3. Sync State : Green (up to date), Blue (syncing), or Yellow (pending changes)
4. Pending Operations : Number of changes waiting to upload, or **"No pending changes"**
5. Last Synced : **"Recently synced"** (<5 min), **"Not synced recently"**, or **"Never synced"**
6. Errors : Upload or download error messages (red), if any

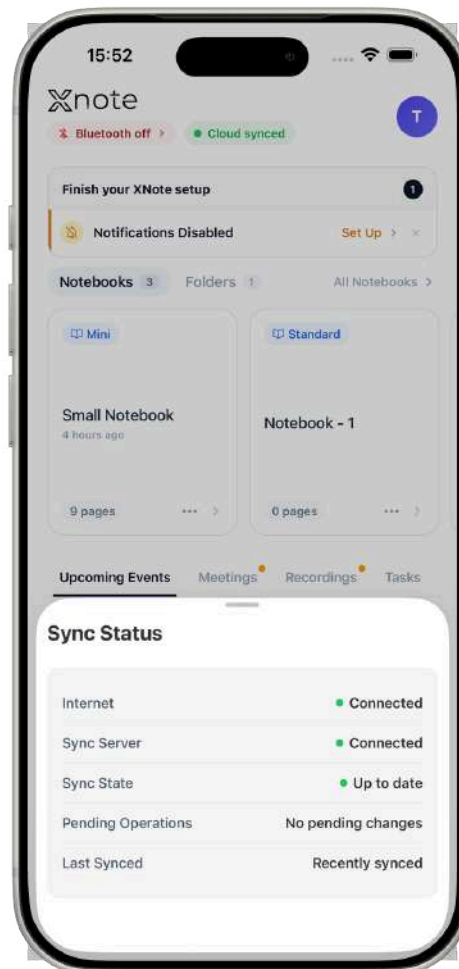

## 2.17 Settings

Access Settings by tapping your profile avatar in the top-right corner of the Home screen.

The Settings screen is organized into the following sections:

At the top, your profile card shows your avatar, name, email, subscription plan badge, audio minute usage bar, and active workflow count (Pro/Unlimited/Lifetime only). Tap the profile area to edit your profile, or tap the subscription area to manage your plan.

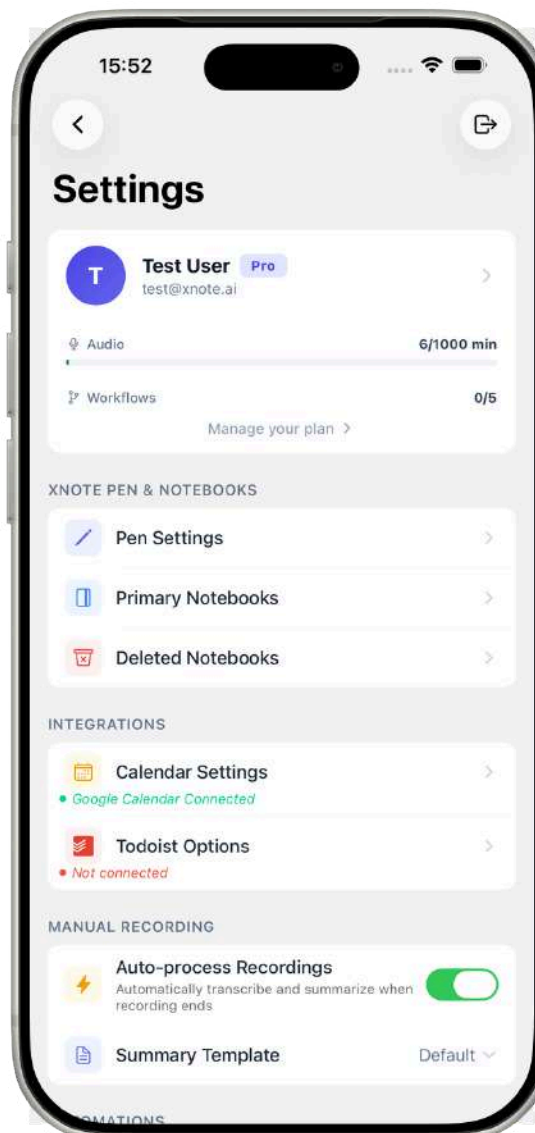

## 2.17.1 Profile

Tap your profile card at the top of Settings to view and edit your account information:

- Name : Tap to change your display name.
- Email : Shown with your login method (Email, Google, or Apple). Email can only be changed for email/password accounts.
- Avatar : Displays your profile photo or initials.
- Member since and last login dates are shown.

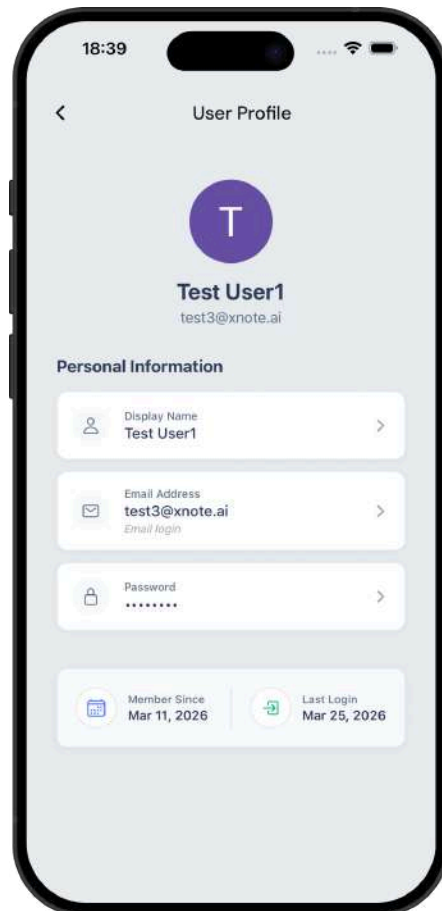

## 2.17.2 Email & Notifications

Change Email (email/password accounts only):

Go to Settings -> Profile -> Change Email.

1. Enter your new email address.

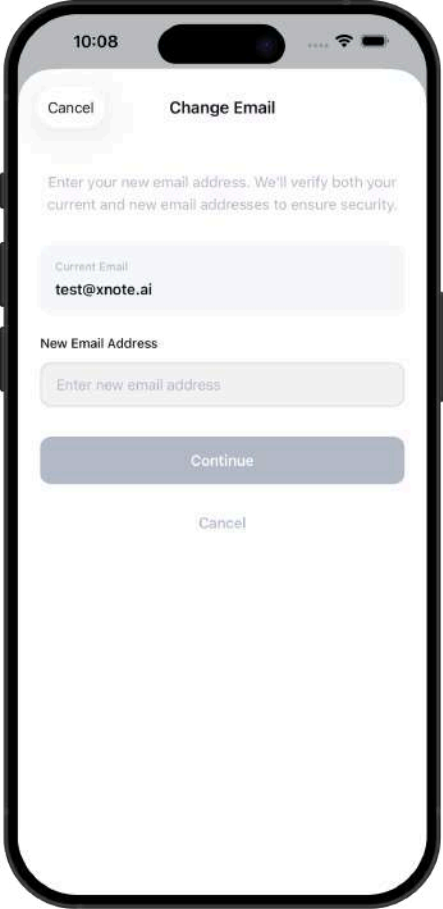

10:08

Cancel Change Email

Enter your new email address. We'll verify both your current and new email addresses to ensure security.

Current Email  
test@xnote.ai

New Email Address

Enter new email address

Continue

Cancel

2. Verify your current email with a 6-digit OTP code.

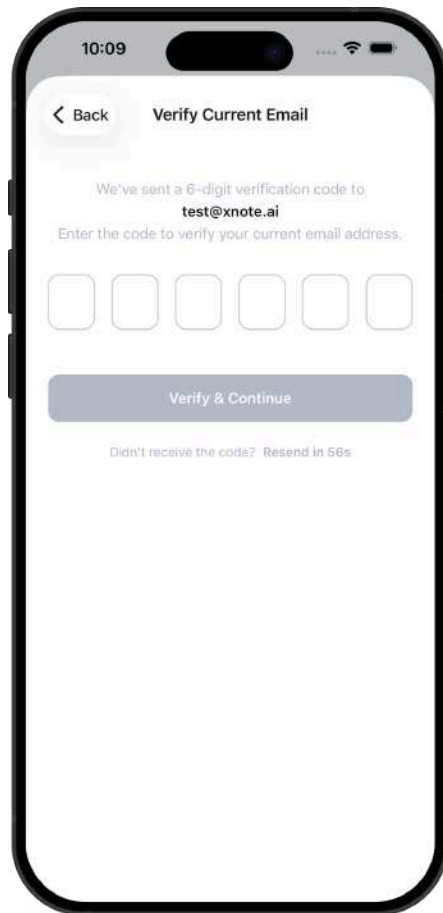

3. Verify the new email with a 6-digit OTP code.

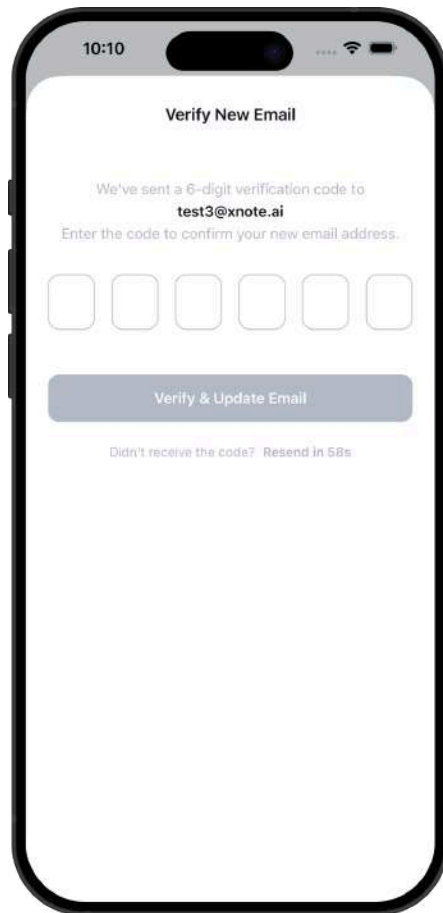

#### 4. Email updated successfully

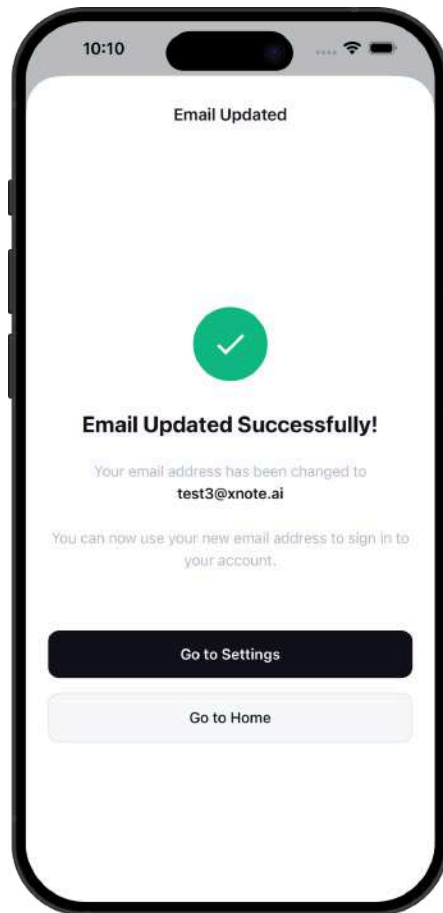

## 2.17.3 Password & Security

Go to Settings -> Profile -> Change Password.

- Enter your current password and set a new one.
- If you signed up with Google or Apple, you can add a password to also enable email/password login.

Password requirements:

- At least 8 characters
- At least one uppercase letter (A-Z), one lowercase letter (a-z), one number (0-9), and one special character

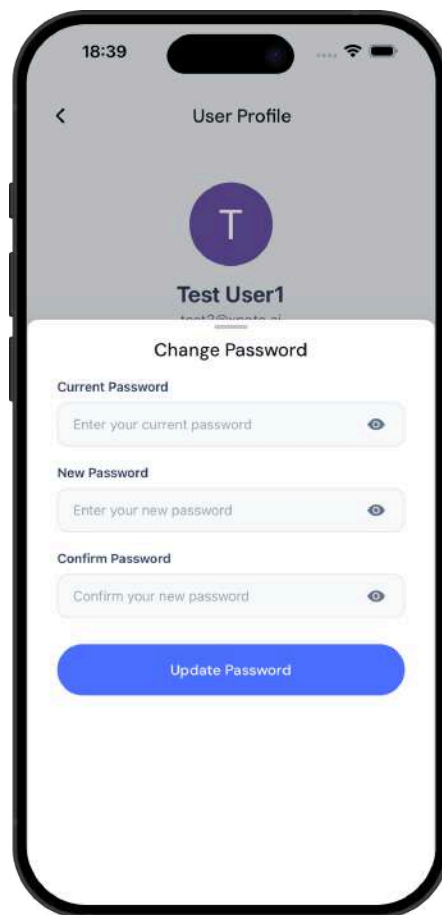

## 2.17.4 Pen & Notebooks

This section in Settings provides quick access to pen and notebook management:

- Pen Settings : Opens the Pen Settings screen. For full details, [\(see 2.7.1\)](#).

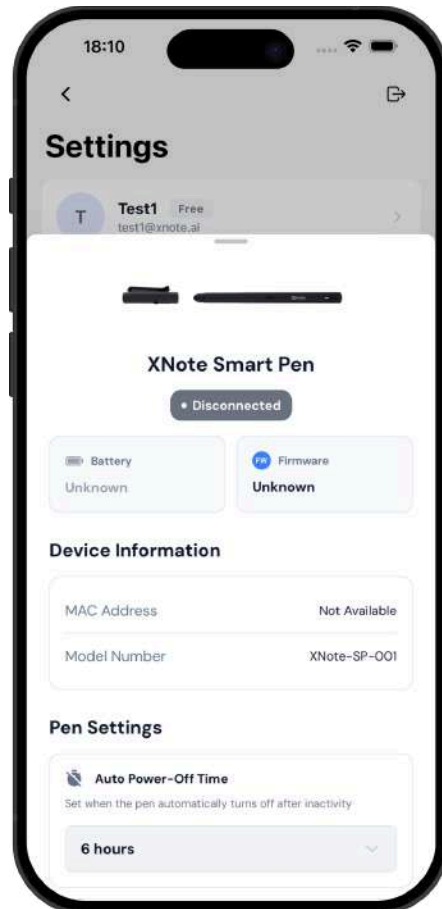

- Primary Notebooks : Opens the Primary Notebooks screen where you can assign a primary notebook for each size (Mini, Standard, Large). To understand what primary notebooks are and why they matter, [see 2.4](#). To set a primary from a notebook's menu, [see 2.6.3](#).

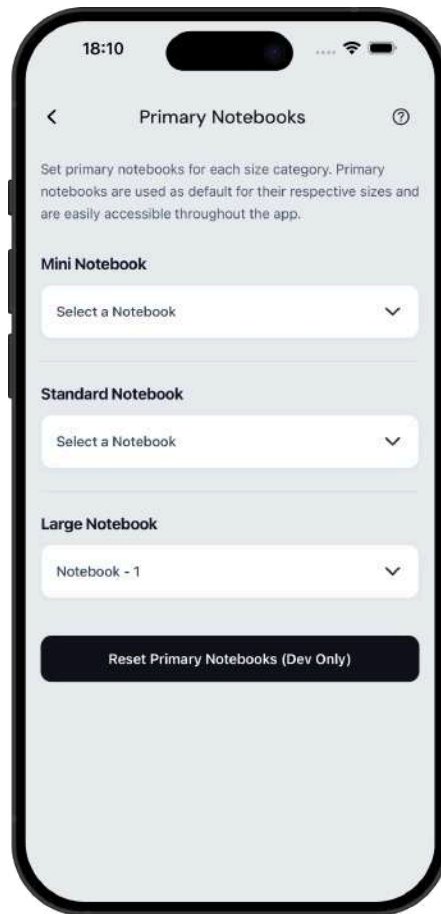

- Deleted Notebooks : View notebooks that were deleted within the last 30 days. Each entry shows the notebook title, creation date, and deletion date. Tap "**Recover**" to restore a deleted notebook. After 30 days, deleted notebooks are permanently removed and cannot be recovered.

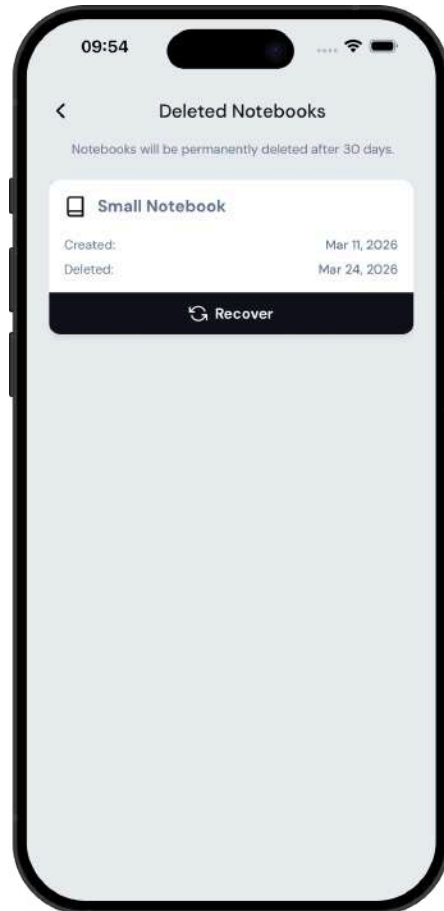

## 2.17.5 Integrations

This section shows the connection status of each integration with a colored indicator (green dot = connected, red dot = not connected).

**Calendar** : Manage your Google Calendar connection. For full setup details, [see 2.12.2](#).

- Connect/disconnect your Google account
- Select which calendars to sync
- Set bot name for meeting recordings
- Choose default transcription language
- Toggle auto-record for all meetings
- Set email preference for summaries (All attendees / Only me / None)
- **Todoist** : Manage your Todoist connection. For full setup details, [see 2.11.4](#).
- Connect/disconnect your Todoist account
- Select workspace, default priority, and labels
- Choose sync mode: Auto or Manual

**Zapier** : Connect XNote with 5,000+ apps via Zapier to automate your workflows. Unlike other integrations, Zapier uses an API key (not OAuth).

**Getting started with Zapier:**

1. Go to Settings -> Zapier.
2. Tap **"Create Zapier Key"**. A unique API key will be generated for your account.
3. Copy the key (displayed in masked format with a copy button).
4. Go to Zapier.com and create a new Zap.
5. Search for **"XNote"** and paste your API key to connect.
6. Set up your automation in Zapier.

To regenerate your key: Tap **"Regenerate"** in the Zapier settings. A confirmation dialog warns that this will invalidate the current key any existing Zapier automations using the old key will stop working until you update them with the new key.

The Zapier settings screen shows your API key creation date and provides copy/regenerate actions.

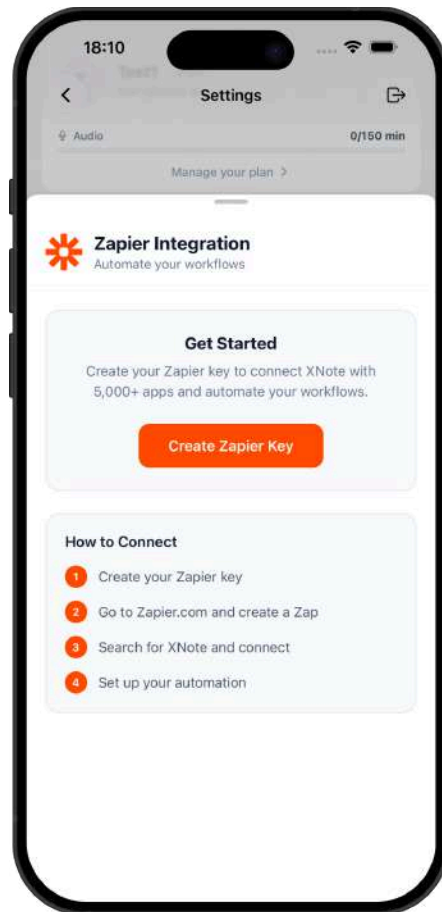

## Setting Up Your Zap on Zapier:

After generating your API key in XNote (see above), follow these steps on Zapier to create your automation. This example demonstrates sending an automatic email via Gmail when a note containing a specific keyword is updated.

### Step 1: Log In to the Zapier Website

Go to the Zapier website and sign in to your account.

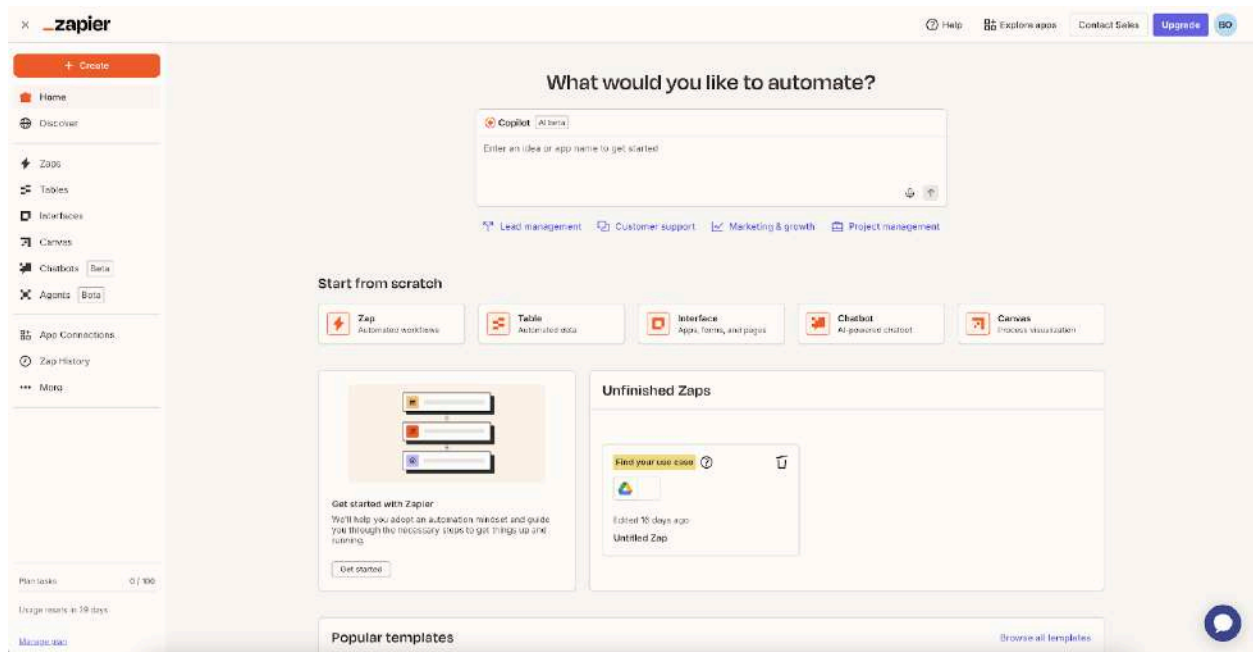

## Step 2: Create a New Zap

On the left sidebar, click Create, then select Zaps. This allows you to create a new automation (workflow).

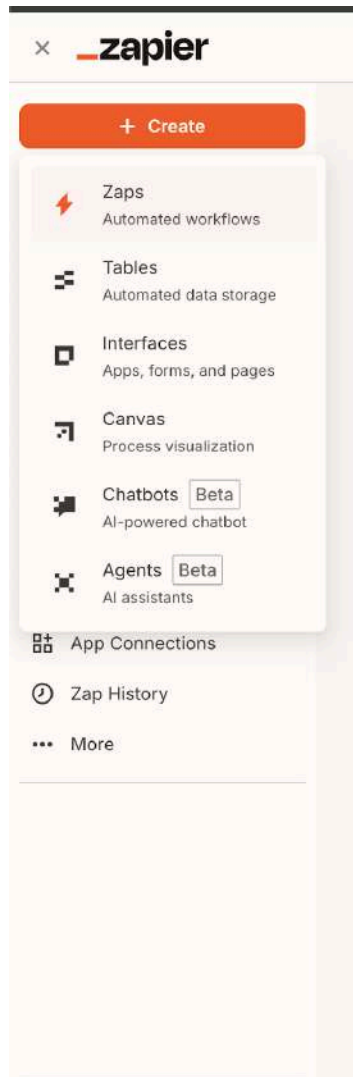

### Step 3: Trigger and Action

You'll see two sections: Trigger and Action. You can optionally describe your workflow, then click on the Trigger button to continue.

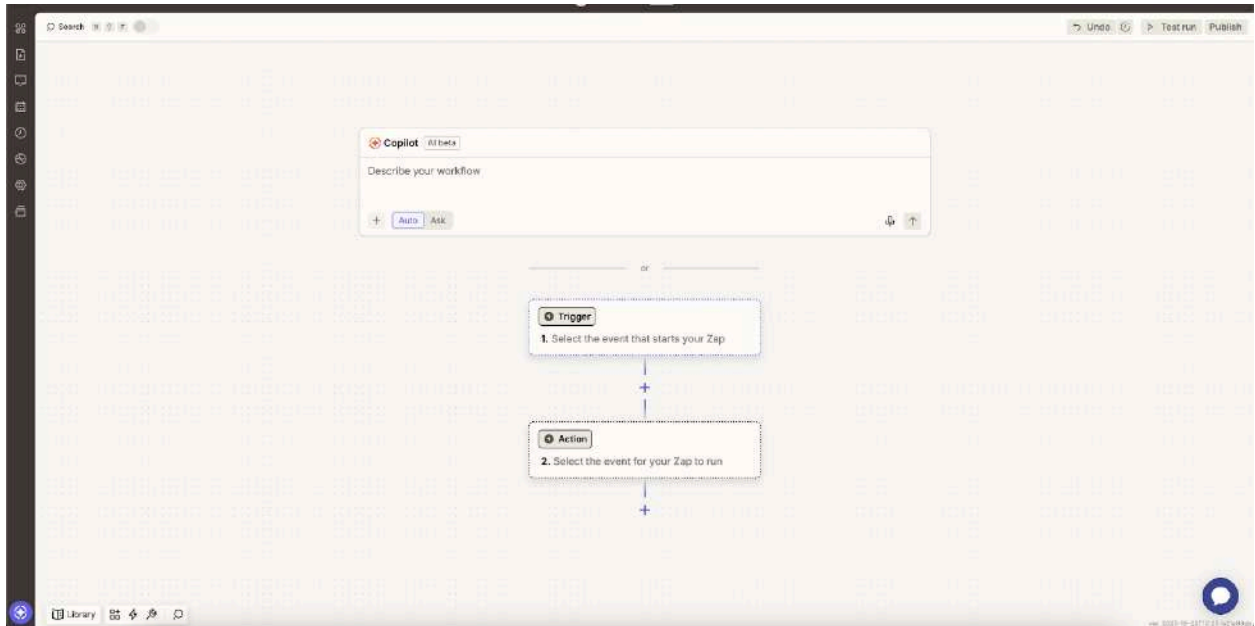

**Step 4:** Select XNote App

In the search bar at the top, type XNote and select it. You'll see XNote (Beta) appear in the list.

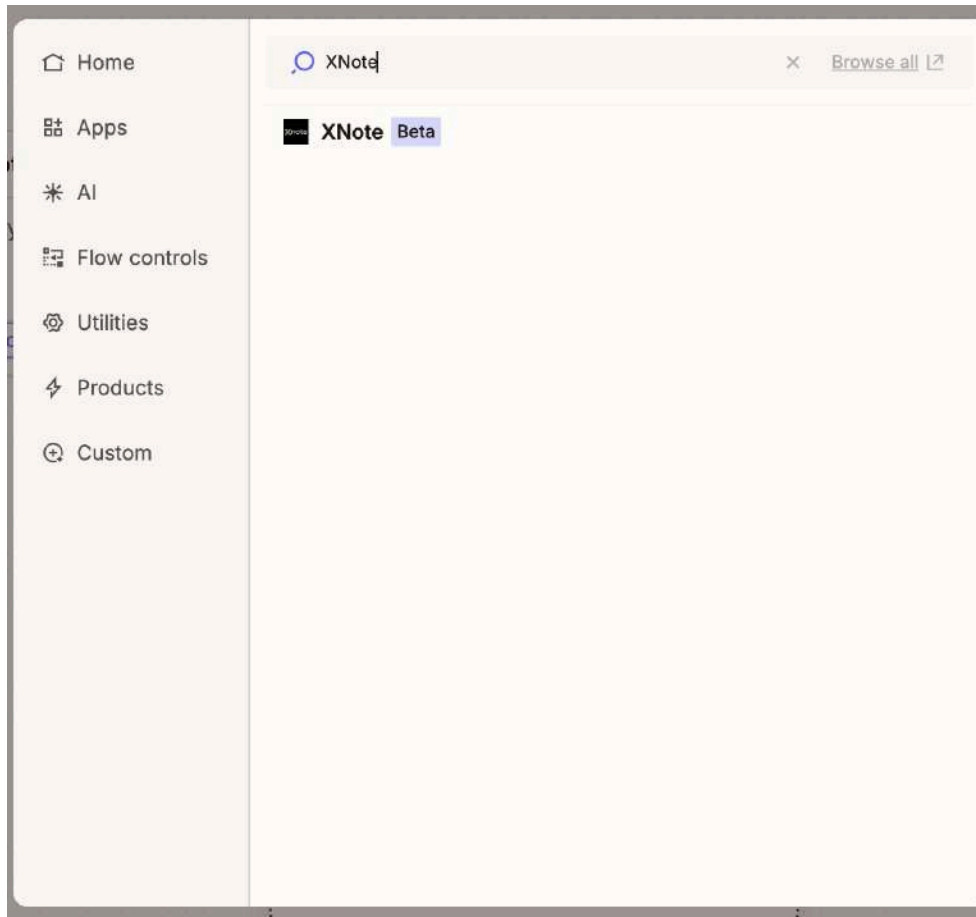

## Step 5: Choose a Trigger Event

On the right panel, click Trigger Event. You'll see several options available under the XNote integration:

The screenshot displays the Zapier configuration interface. The central workspace shows a workflow diagram with two steps: a Trigger step labeled '1. Select the event' and an Action step labeled '2. Select the event for your Zap to run'. The right-hand panel is titled '1. Select the event' and contains the following fields:

- App:** XNote (Beta) with a 'Change' button.
- Trigger event:** A dropdown menu with the text 'Choose an event'.
- Account:** 'Connect XNote' with a 'Sign in' button.

Below these fields, there is a disclaimer: 'XNote is a secure partner with Zapier. Your connected accounts are encrypted and can be removed at any time. You can manage all of your connected accounts here.' At the bottom of the panel, a button reads 'To continue, choose an event'. A blue circle highlights this button in the original image.

Trigger	When It Fires
Task Created	A new task is added in XNote
Task Updated	An existing task is modified
Event Created	A new calendar event is created in XNote
Event Updated	An existing event changes
Note Updated With Text Condition	A note containing a specific keyword or phrase is updated

All these triggers are directly connected to the core XNote functions — you can use them to build powerful automation workflows based on tasks, events, or notes. For this guide, we'll use Note Updated With Text Condition as an example.

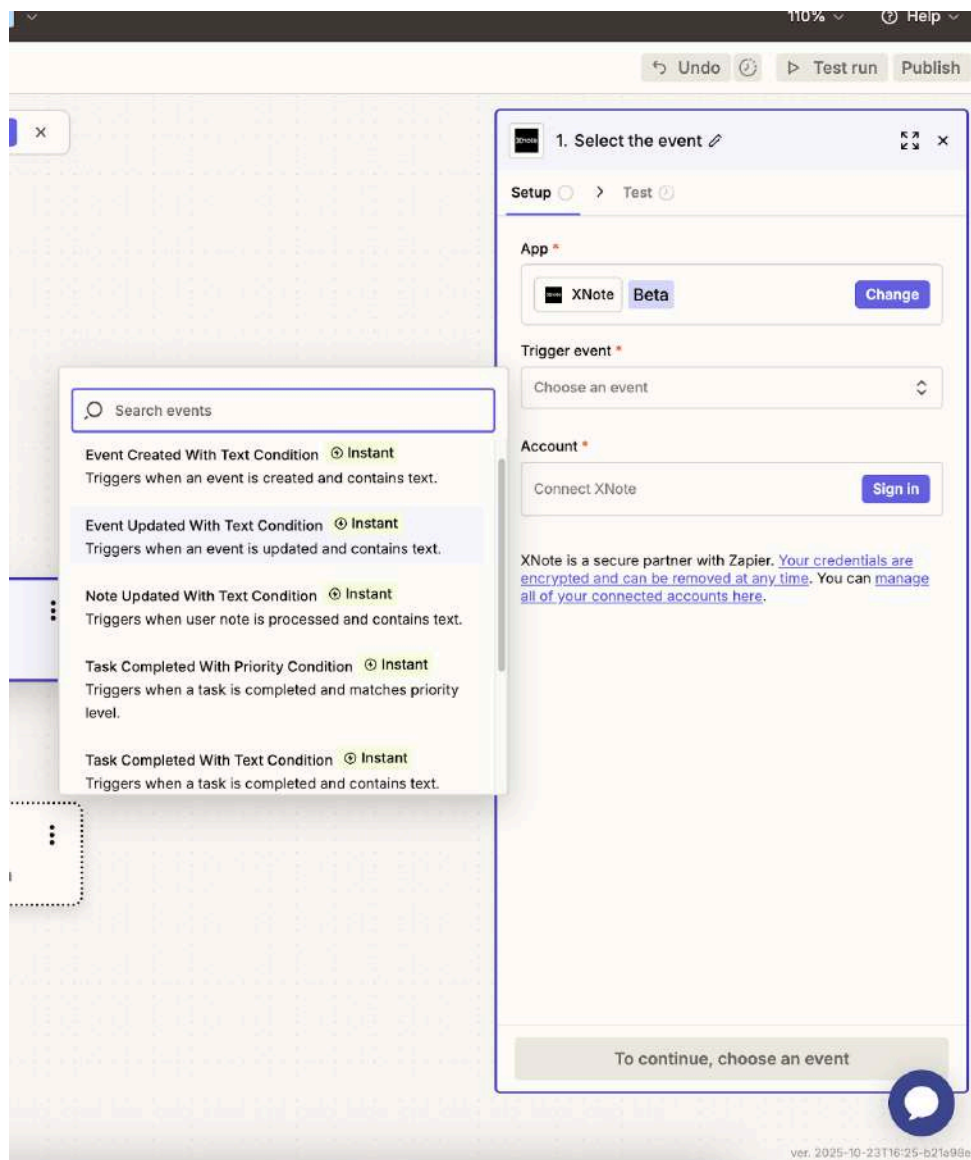

## Step 6: Sign In to Your Account

After selecting the trigger, click the Sign In button under the Account section.

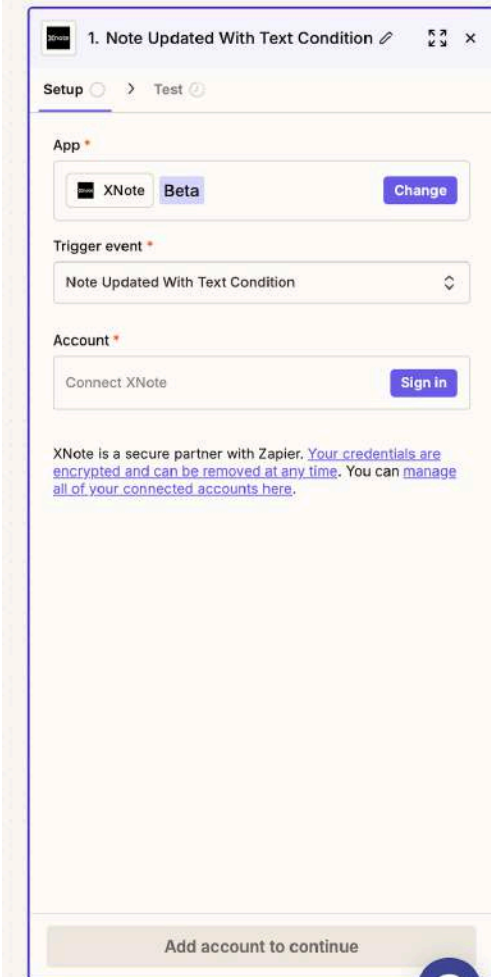

The screenshot shows the Zapier configuration page for a trigger. The title is "1. Note Updated With Text Condition". Below the title, there are two tabs: "Setup" (selected) and "Test". The "App" section shows "XNote" with a "Beta" badge and a "Change" button. The "Trigger event" section shows "Note Updated With Text Condition" with a dropdown arrow. The "Account" section shows "Connect XNote" and a "Sign in" button. Below the "Account" section, there is a message: "XNote is a secure partner with Zapier. [Your credentials are encrypted and can be removed at any time.](#) You can [manage all of your connected accounts here.](#)" At the bottom of the form, there is a button that says "Add account to continue".

1. Note Updated With Text Condition

Setup > Test

App \*

XNote Beta Change

Trigger event \*

Note Updated With Text Condition

Account \*

Connect XNote Sign in

XNote is a secure partner with Zapier. [Your credentials are encrypted and can be removed at any time.](#) You can [manage all of your connected accounts here.](#)

Add account to continue

-server \*:6379 — 80x24

ver. 2025-10-23T16:25-b21a98eb

### Step 7: Log In with Zapier Key

In the login screen, paste the Zapier Key you generated in the app, and click Yes, Continue to XNote.

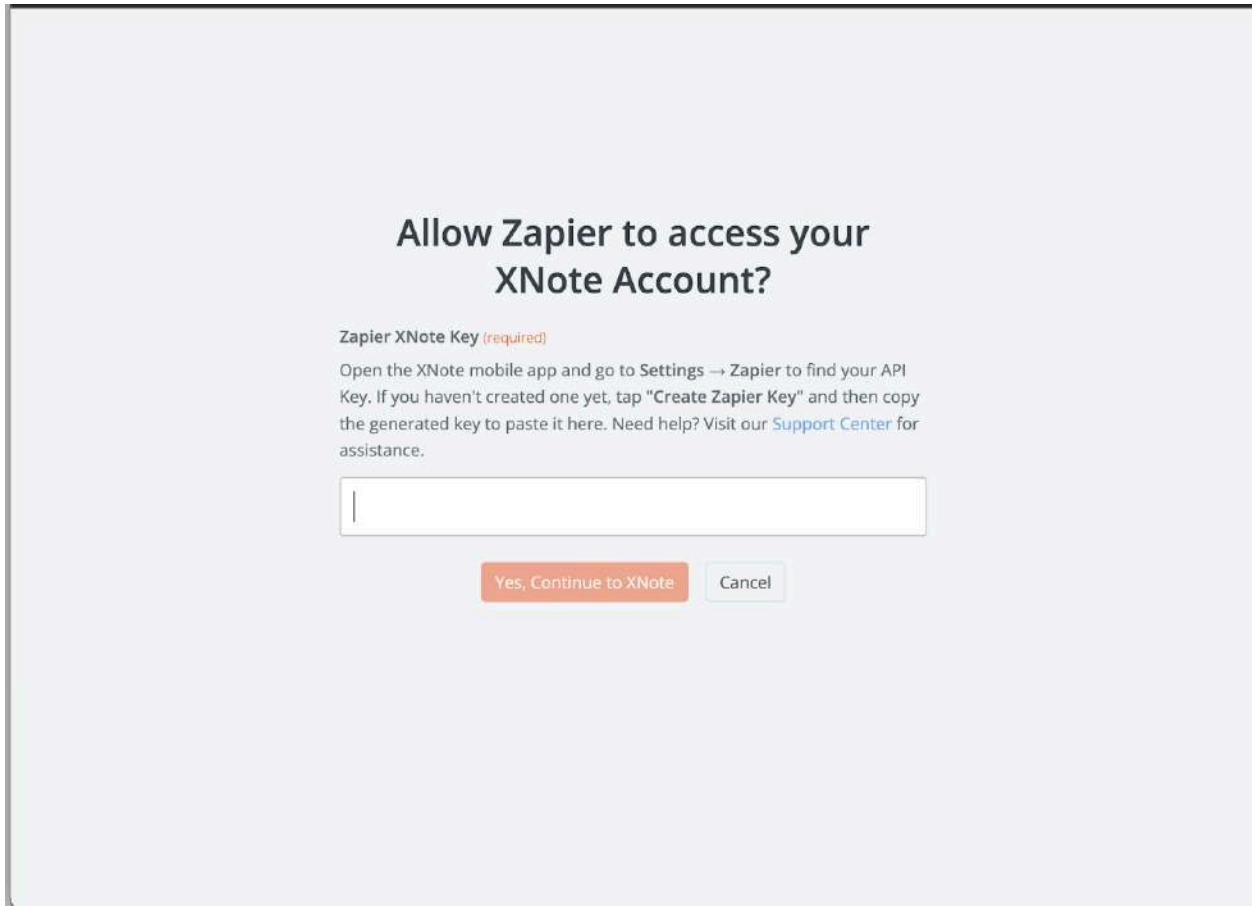

**Allow Zapier to access your XNote Account?**

Zapier XNote Key *(required)*

Open the XNote mobile app and go to Settings → Zapier to find your API Key. If you haven't created one yet, tap "Create Zapier Key" and then copy the generated key to paste it here. Need help? Visit our [Support Center](#) for assistance.

## Step 8: Complete Initial Setup

Finish the initial setup and click Continue.

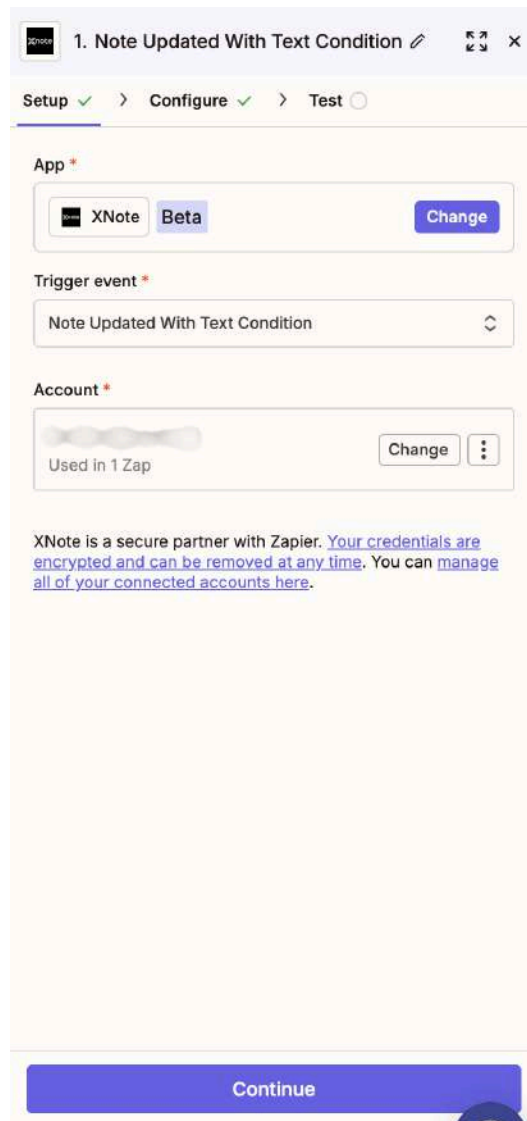

The screenshot shows a web browser window with the title "1. Note Updated With Text Condition". The browser's address bar and navigation tabs are visible. The page content is a setup form for a Zap. At the top, there are three steps: "Setup" (checked), "Configure" (checked), and "Test" (unchecked). The "App" section is selected, showing "XNote Beta" with a "Change" button. The "Trigger event" section is set to "Note Updated With Text Condition". The "Account" section shows a blurred account name with a "Change" button and a menu icon. Below the account section, there is a security notice: "XNote is a secure partner with Zapier. Your credentials are encrypted and can be removed at any time. You can manage all of your connected accounts here." At the bottom of the page, there is a large blue "Continue" button.

1. Note Updated With Text Condition

Setup ✓ > Configure ✓ > Test ○

App \*

XNote Beta Change

Trigger event \*

Note Updated With Text Condition

Account \*

Used in 1 Zap Change

XNote is a secure partner with Zapier. [Your credentials are encrypted and can be removed at any time.](#) You can [manage all of your connected accounts here.](#)

Continue

### Step 9: Set Your Condition (Keyword)

In the Configure section, specify the condition or keyword that will trigger your workflow. For example, in this tutorial, we use the keyword XNote.



The screenshot shows a mobile application interface for configuring a workflow. At the top, there is a title bar with a small icon, the text "1. Note Updated With Text Condition", and a close button. Below the title bar is a navigation bar with three items: "Setup" with a green checkmark and a right arrow, "Configure" with a green checkmark and a right arrow, and "Test" with a grey circle and a right arrow. To the right of the navigation bar are three icons: a blue diamond, a blue circular arrow, and a magnifying glass. The main content area has a light orange background. At the top of this area is the text "If Note Contains Specific Text" followed by a small circular icon with an "i". Below this text is a text input field with a blue border and the text "XNote" inside. At the bottom of the screen is a blue button with the text "Continue".

## Step 10: Create a Record

Next, you'll see the Record section. Create a new record to proceed.

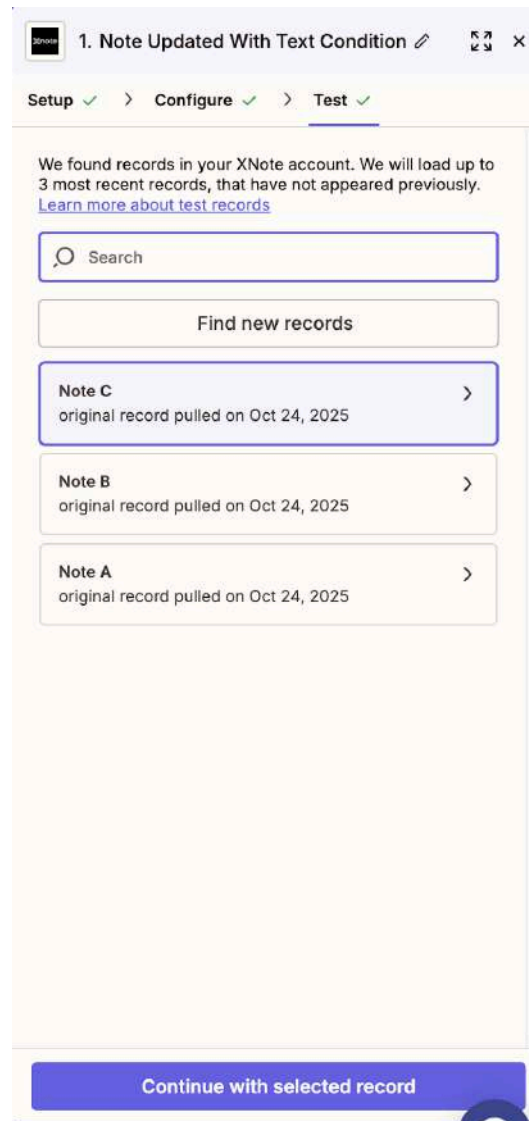

## Step 11: Choose Action App

Now move to the Action section. Here, you decide what should happen after the trigger. For this example, choose Gmail.

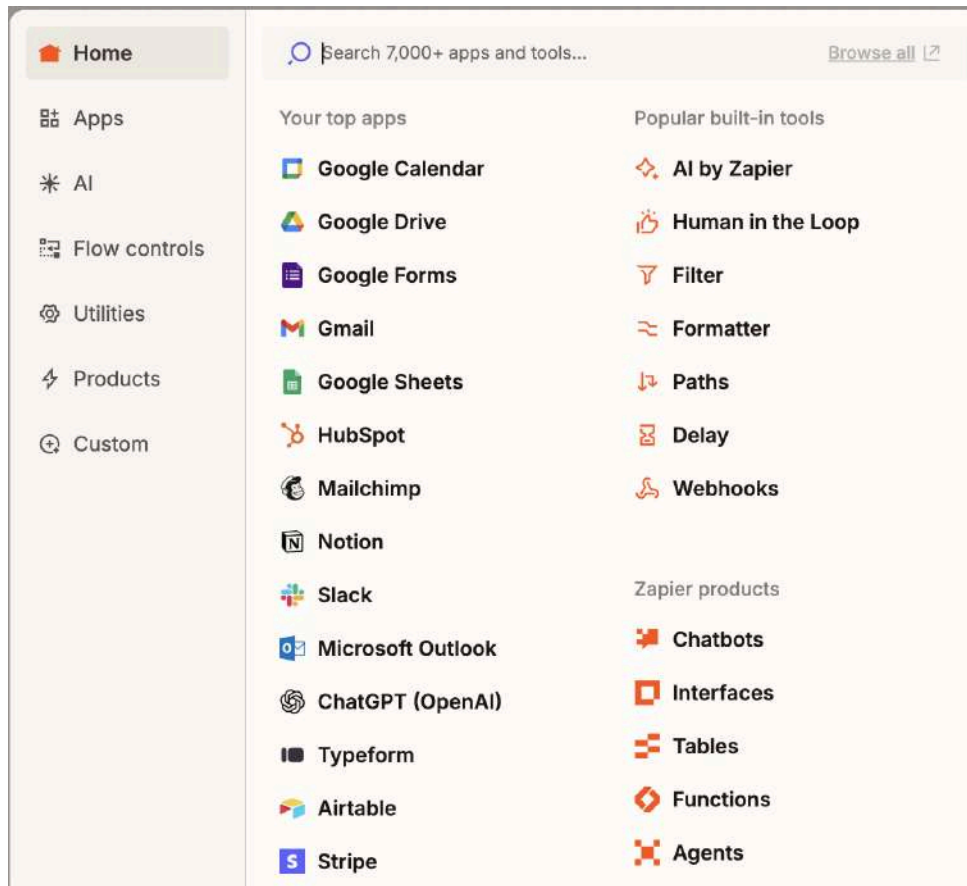

## Step 12: Select Gmail Event

In the Gmail setup screen, click Choose an Event and select Send Email. This means an email will be sent when the trigger condition is met.

The screenshot displays the Zapier interface for setting up a Gmail action. The main window is titled "2. Select the event" and has tabs for "Setup" and "Test".

- App:** Set to "Gmail" with a "Change" button.
- Action event:** A dropdown menu is open, showing "Choose an event".
- Account:** A "Connect Gmail" button with a "Sign in" button.

Below the account section, there is a security notice: "Gmail is a secure partner with Zapier. [Your credentials are encrypted and can be removed at any time.](#) You can [manage all of your connected accounts here.](#)"

At the bottom of the main window, a grey bar says "To continue, choose an event".

On the left side, a search bar labeled "Search events" is visible. Below it, a list of events is shown:

- Remove Label From Email  
Remove a label from an email message.
- Reply to Email  
Send a reply to an email message.
- Send Email** (highlighted)  
Create and send a new email message.
- SEARCH
- Find Email  
Finds an email message. Optionally, create an email if none are found.

### Step 13: Connect Gmail Account

Select the Gmail account you want to use for this action and click Continue.

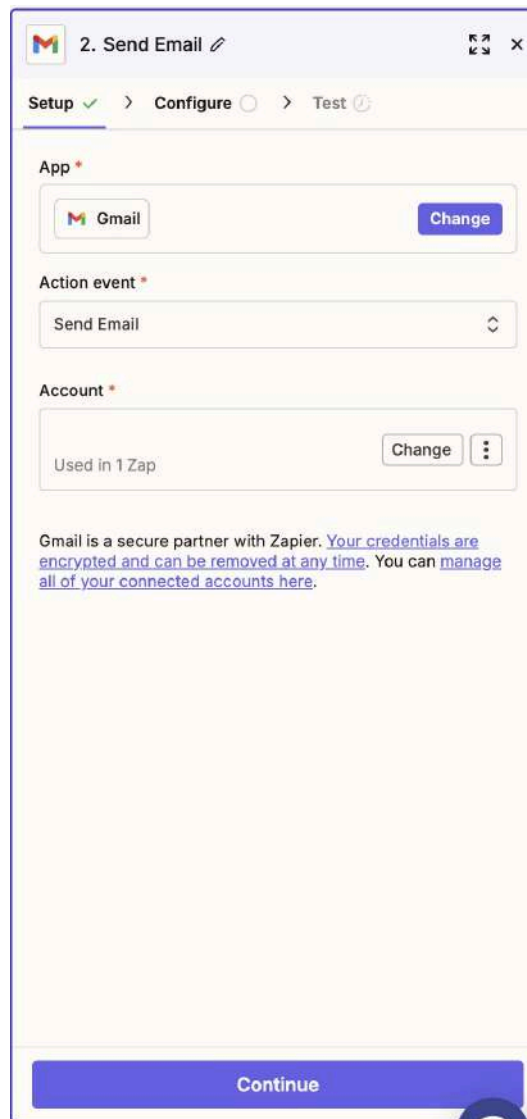

The screenshot shows a web browser window titled "2. Send Email" with a progress bar at the top indicating the "Configure" step is active. The interface includes three main sections: "App" with a "Gmail" selection and a "Change" button; "Action event" with a dropdown menu set to "Send Email"; and "Account" with a selection area showing "Used in 1 Zap" and a "Change" button. A blue "Continue" button is located at the bottom of the configuration area. A security notice at the bottom of the page states: "Gmail is a secure partner with Zapier. [Your credentials are encrypted and can be removed at any time.](#) You can [manage all of your connected accounts here.](#)"

## Step 14: Configure Email Content

Define how your email should look. Fill in the To, Subject, and Body fields. You can insert dynamic content from XNote (like note text or title) using the options on the left. In the Body section, you'll see two options: "Step Out" and "Updated Note Content."

- Select "Updated Note Content" if you want the page content to appear in the email.
- For other triggers (tasks or events), if you see "Step Out", it means you can view the raw data in JSON format.

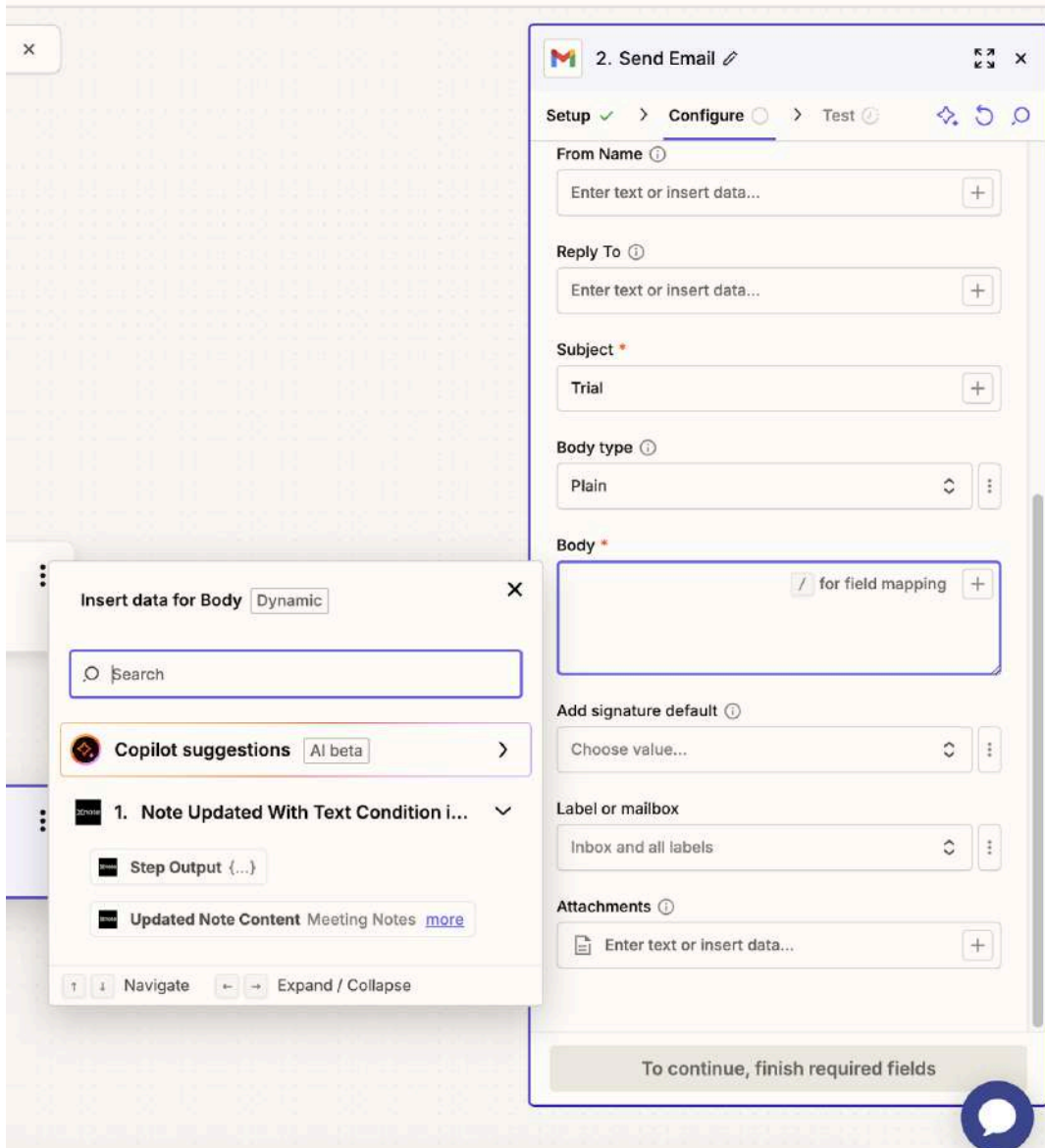

## Step 15: Test and Preview

Preview how the email will appear. For example, select Updated Note Content and add a line such as "This is trial". Then click Continue.

2. Send Email

Setup ✓ > Configure ✓ > Test ⚠

From Name ⓘ  
Enter text or insert data... +

Reply To ⓘ  
Enter text or insert data... +

Subject \*  
Trial +

Body type ⓘ  
Plain

Body \*  
1. Updated Note Content: Meeting Notes -...an +  
d next steps  
This is trial.

Add signature default ⓘ  
Choose value... ▾ ⋮

Label or mailbox  
Inbox and all labels ▾ ⋮

Attachments ⓘ  
Enter text or insert data... +

Continue

## Step 16: Test and Publish

After testing successfully, click Publish to activate your Zap.

The screenshot shows the configuration step for a Zap. The breadcrumb navigation is 'Setup' (checked) > 'Configure' (selected) > 'Test' (disabled). The 'App' is set to 'Gmail' with a 'Change' button. The 'Action event' is 'Send Email'. The 'Account' is a blurred email address with a 'Change' button and a 'Used in 1 Zap' indicator. A note at the bottom states: 'Gmail is a secure partner with Zapier. Your credentials are encrypted and can be removed at any time. You can manage all of your connected accounts here.' A large blue 'Continue' button is at the bottom.

The screenshot shows the test results for the '2. Send Email' step. The breadcrumb navigation is 'Setup' (checked) > 'Configure' (checked) > 'Test' (checked). The step is titled 'Send Message to Gmail' with a note: 'We'll use this as a sample for setting up the rest of your Zap.' A success message reads: 'A Message was sent to Gmail about in 0 seconds'. Below is a 'Data in' / 'Data out' section with a search bar. The 'Data out' contains: ID: 19a159791b8d91ff, Thread Id: 19a159791b8d91ff, Label Ids: 1 SENT. An 'Edit' button is next to the data. At the bottom are 'Retest step' and 'Publish' buttons.

## Step 17: Final Result

Your Zap is now active! Whenever you write a sentence containing XNote in your notebook, the trigger will activate, and an automatic email will be sent.

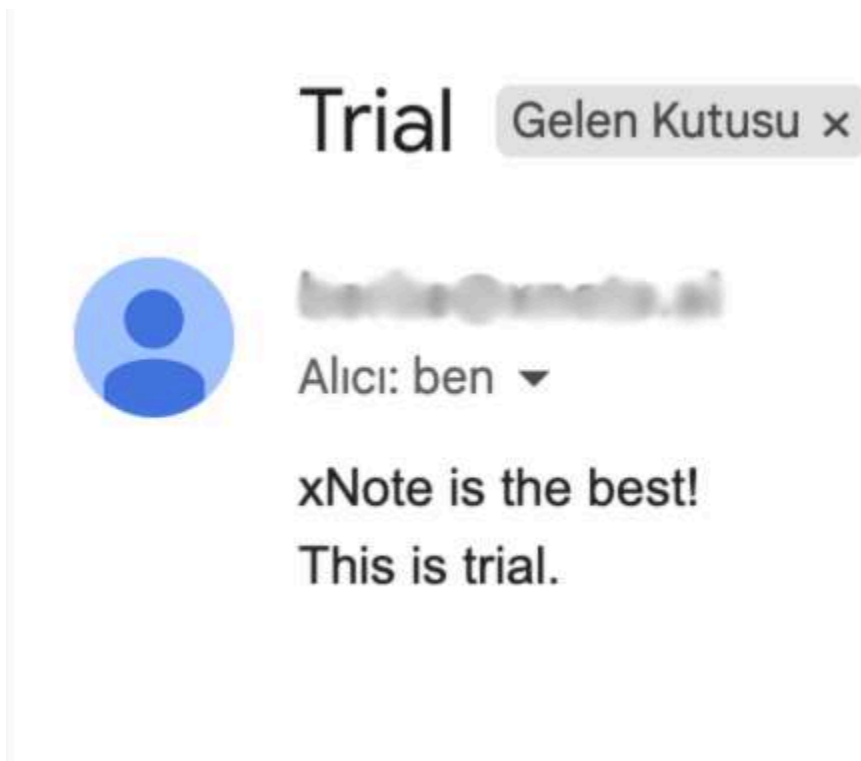
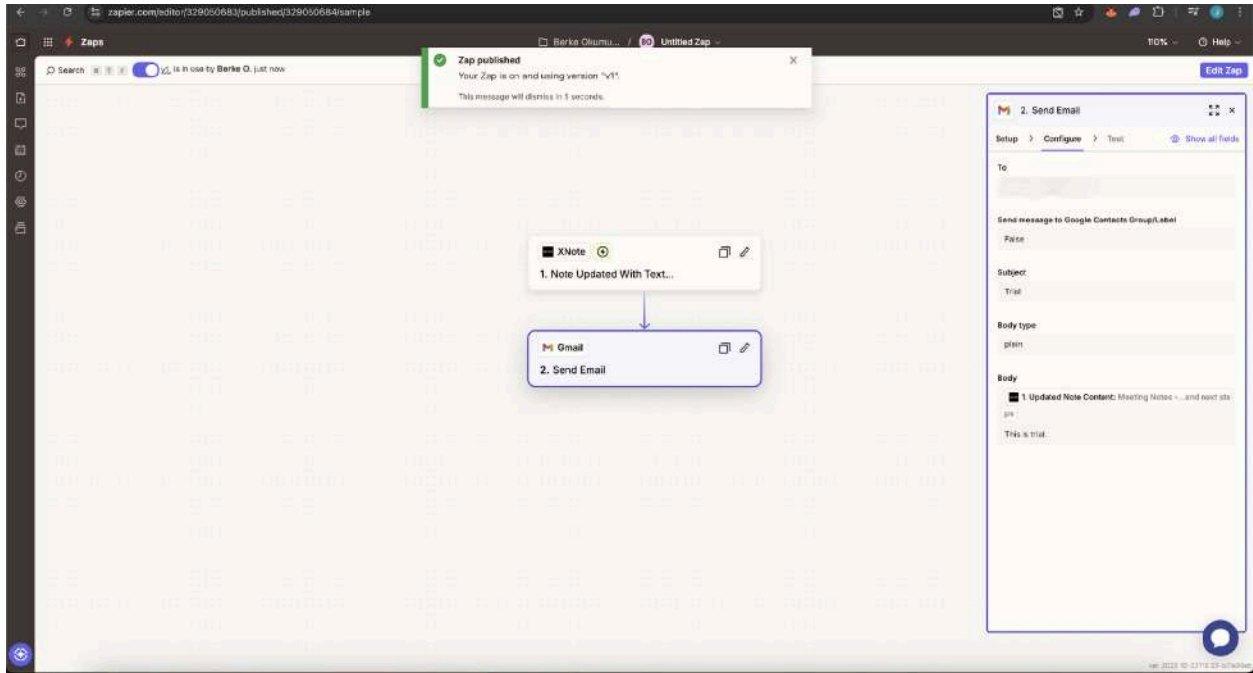

## 2.17.6 Automations

- Workflows : Opens the Automations management screen. For full details, [see 2.13](#)

## 2.17.7 General

- Date Format : Tap to choose between two formats:

- MM/DD/YYYY - 12 hour

- DD/MM/YYYY - 24 hour

The selected format is applied across the entire app for dates and times.

- Language Settings : Tap to open your device's system settings where you can change the app language. XNote uses your device language setting.

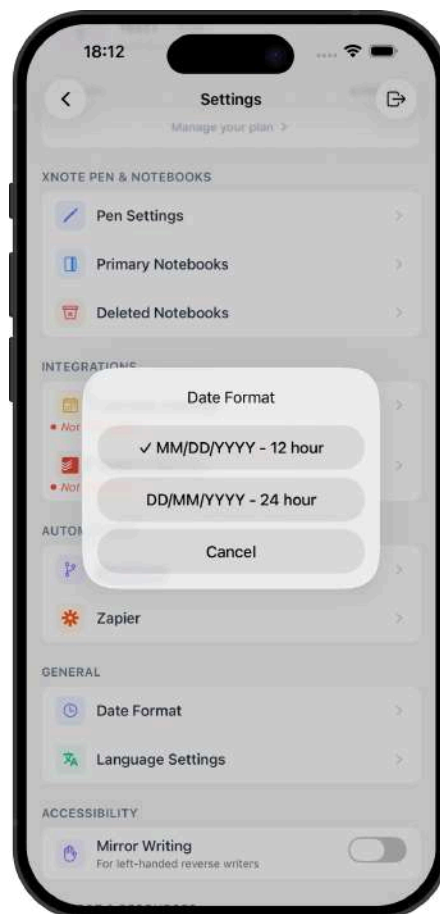

## 2.17.8 Accessibility

- Mirror Writing : A toggle for left-handed users who write in reverse (mirror writing). When enabled, the canvas is flipped horizontally. For full details and important warnings, [see 2.7.1.](#)

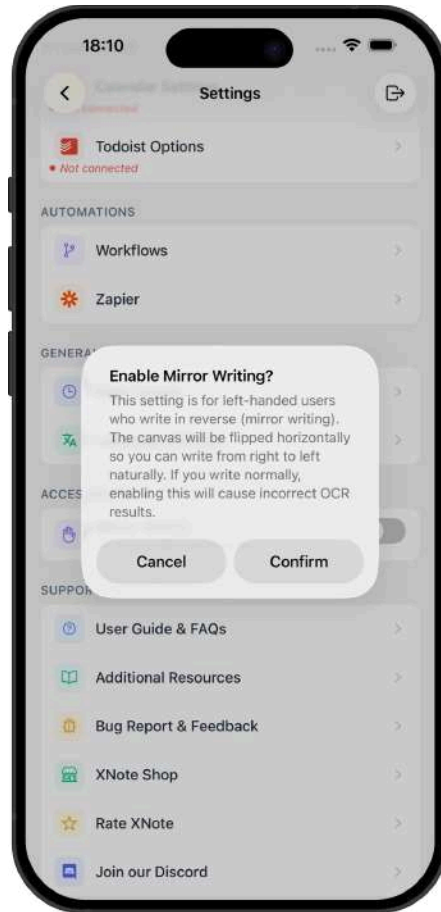

## 2.17.9 Support & Resources

- User Guide : Opens the XNote support site (<https://support.xnote.ai>).
- Additional Resources : Shows app version, build number, runtime version, crash report toggle, privacy policy, and terms of service links.
- Bug Report & Feedback : Opens a Zendesk support form to submit issues or suggestions.
- XNote Shop : Opens the XNote store website.
- Rate App : Prompts the system review dialog to rate XNote on the App Store or Google Play.
- Join Discord : Opens the XNote Discord community for discussions and support.

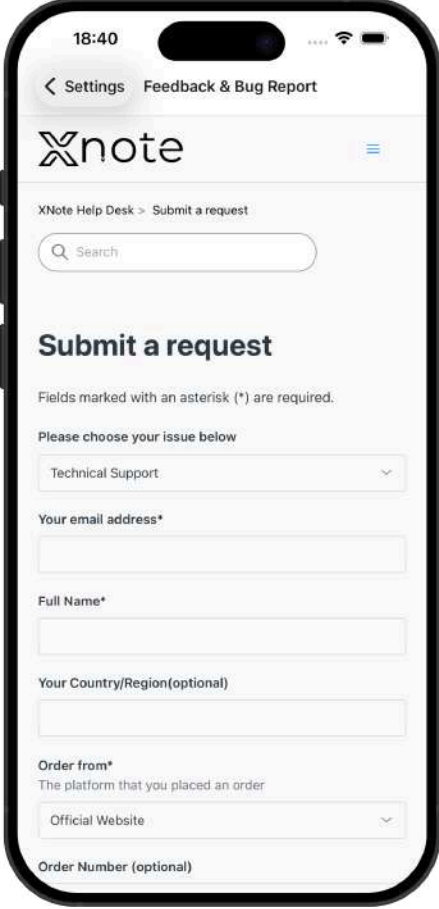

The screenshot shows the 'Feedback & Bug Report' screen in the XNote app. At the top, the time is 18:40 and the status bar shows signal, Wi-Fi, and battery icons. The navigation bar includes a back arrow, 'Settings', and 'Feedback & Bug Report'. The XNote logo is prominently displayed. Below the logo, there is a breadcrumb trail 'XNote Help Desk > Submit a request' and a search bar. The main heading is 'Submit a request'. A note states 'Fields marked with an asterisk (\*) are required.' The form includes a dropdown menu for 'Please choose your issue below' with 'Technical Support' selected. Below this are input fields for 'Your email address\*', 'Full Name\*', and 'Your Country/Region(optional)'. There is also a dropdown for 'Order from\*' with 'Official Website' selected, and a final field for 'Order Number (optional)'.

## 2.17.10 Account Deletion

Go to Settings -> Danger Zone -> Delete Account.

1. Tap **"Delete Account"**.
  2. A first confirmation asks: **"Are you sure you want to delete your account?"**
  3. A second confirmation warns: **"Your account and all data will be deleted permanently."**
  4. On confirm, account deletion is scheduled, you are signed out, and all local data is cleared.
- A loading indicator is shown during the deletion process.

Important: Account deletion is not immediate it is scheduled. If you sign back in before the deletion is finalized, you will see an Account Deletion Warning screen with a countdown showing when your account will be permanently deleted. From this screen, you can tap **"Cancel Deletion"** to restore your account and keep all your data. Once the deletion is finalized, it is irreversible.

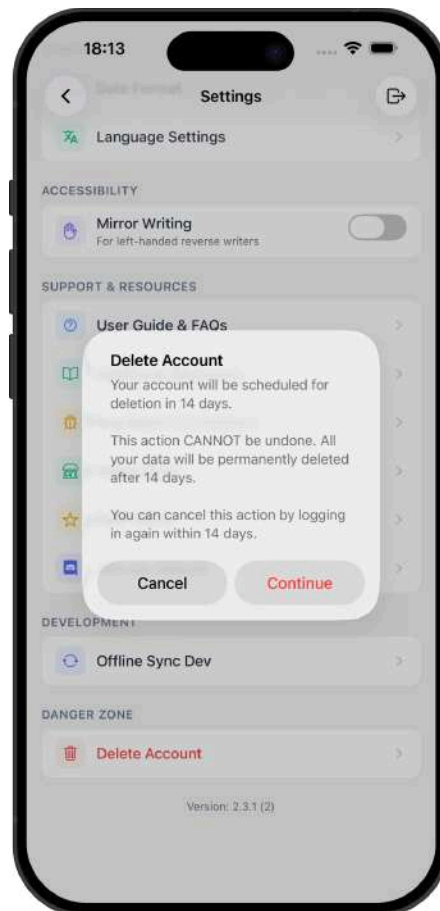

### **2.17.11 App Updates**

XNote periodically checks for app updates. If a required update is available, an update screen will appear when you open the app:

- The screen shows what's new in the latest version.
- Tap "**Update**" to be redirected to the App Store (iOS) or Google Play (Android) to download the update.
- You cannot continue using the app until the required update is installed.

Minor updates (bug fixes and improvements) may be applied automatically in the background without requiring a store download.

### **2.17.12 Rate App**

After using XNote for a while, a Rate App prompt may appear asking you to rate your experience.

### **2.17.13 Sign Out**

Tap the sign-out icon in the top-right corner of the Settings screen. A confirmation dialog will appear. On confirm, the app clears your local cache, disconnects the pen, and returns you to the Welcome screen.

## 2.18 Subscription

Manage your subscription plan, track usage, and redeem codes from Settings -> Subscription. You can also access the subscription screen by tapping the plan badge or usage area on the Settings profile card.

### 2.18.1 View Current Plan

The subscription screen shows:

- Current plan name with icon (Free, Pro, Unlimited, or Lifetime)
- Billing period (Monthly or Yearly)
- Renewal date ("renews on [date]") or cancellation date ("cancels on [date]" in orange if set to cancel)
- Audio minutes usage bar with color coding (green = 0-50%, orange = 50-80%, red = >80%)
- Active workflows count (Pro/Unlimited/Lifetime only)
- Quick action buttons: Upgrade Plan, Buy More Minutes, Redeem Code, Manage Subscription, Restore Purchases
- Subscription timeline (history) at the bottom

For a full comparison of plans, audio minute limits, and workflow quotas, [see Section 4.1](#).

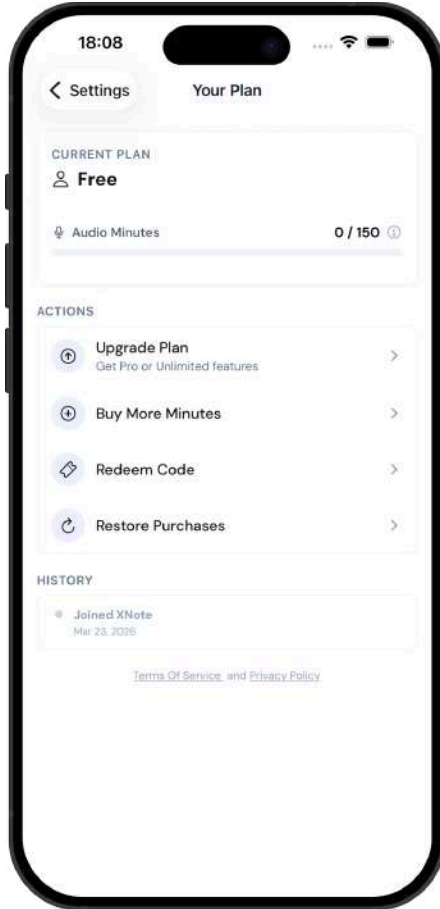

18:08

< Settings

Your Plan

CURRENT PLAN

👤 Free

🔊 Audio Minutes 0 / 150 ⓘ

ACTIONS

- ⓘ Upgrade Plan >  
Get Pro or Unlimited features
- ⓘ Buy More Minutes >
- 🔑 Redeem Code >
- 🔄 Restore Purchases >

HISTORY

- Joined XNote  
Mar 23, 2025

[Terms Of Service](#) and [Privacy Policy](#)

## 2.18.2 Usage Tracking (Audio Minutes, Workflows)

### Audio Minutes:

A progress bar on the subscription screen shows your used vs. total minutes. Tap the info icon to open the Audio Usage Details modal showing:

- Total Remaining Minutes : Combined total of monthly + add-on minutes
- Monthly Minutes section (tag: "**Resets Monthly**"):
  - Monthly limit
  - Used this month
  - Remaining (highlighted in blue)
  - Next reset date
- Add-on Minutes section (tag: "**Never Expires**"):
  - Available add-on minutes (highlighted in blue)
- Usage Priority note: Monthly subscription minutes are used first. Add-on minutes are used only after monthly minutes are exhausted.

### When minutes are low:

- Orange warning when usage exceeds 50%
- Red warning when usage exceeds 80%
- If a recording exceeds your remaining quota, you can choose partial transcription or purchase more minutes
- When fully exhausted, a red banner prompts you to get more minutes

### Workflows:

Shows the count of active workflows vs. your plan limit. Tap the info icon to open the Workflow Details modal showing:

- Active workflow count (large display)
- For Pro plans: Workflow limit, currently active, and remaining slots
- For Unlimited plans: "**Unlimited**" label with current active count
- Upgrade card (Pro users only): "**Need more workflows?**" prompt with upgrade button to Unlimited

Only active automations count toward your limit. Inactive automations do not use quota.

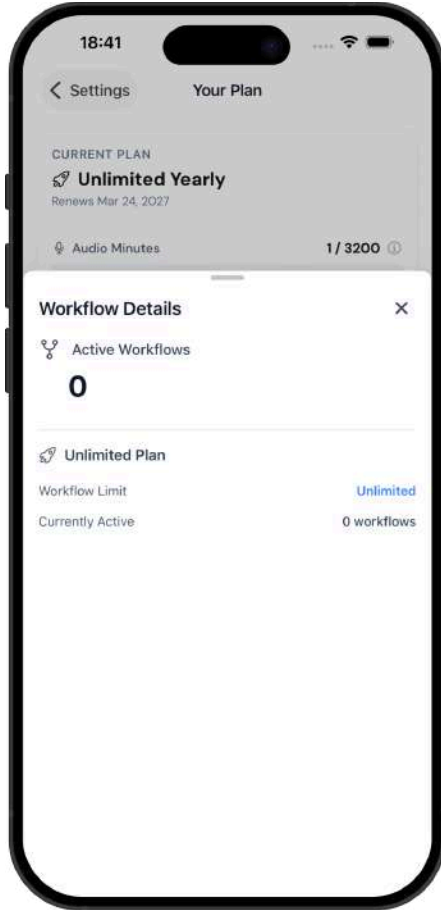

## 2.18.3 Upgrade via Paywall

Tap **"Upgrade Plan"** to open the paywall. The paywall is rendered natively by your device's app store (via Adapty SDK).

Available upgrade paths:

- Free -> Pro or Unlimited : Full paywall with plan comparison and pricing
- Pro -> Unlimited : Dedicated upgrade paywall showing only the Unlimited plan

Pricing is displayed in your local currency as set by the App Store (iOS) or Google Play (Android). Monthly and yearly billing options are available where applicable.

Purchases are processed securely through the App Store or Google Play. XNote does not handle payment information directly.

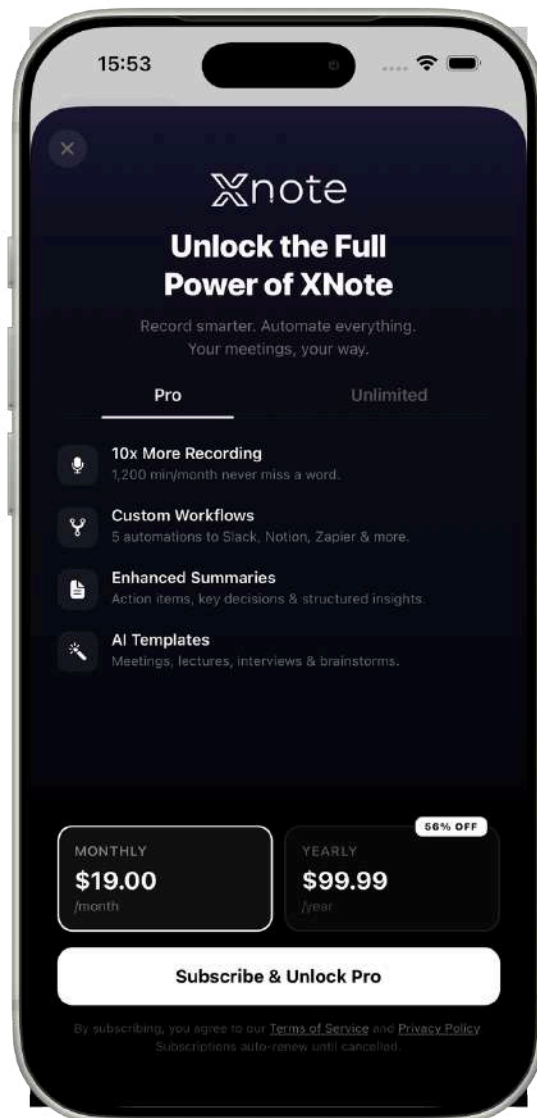

## 2.18.4 Buy More Minutes

Tap **"Buy More Minutes"** on the subscription screen to purchase add-on audio minutes that never expire.

The Buy Minutes screen shows:

- Available minute packages loaded from the store, sorted by size (largest first)
- Each package displays: minute count, price, and cost per minute
- **"Best Value"** badge on the largest package
- **"Save X%"** badge showing savings compared to the smallest package
- Radio button to select your preferred package

After selecting a package, tap **"Buy [count] minutes - [price]"** to complete the purchase through the App Store (iOS) or Google Play (Android).

Add-on minutes never expire and are used only after your monthly subscription minutes are exhausted.

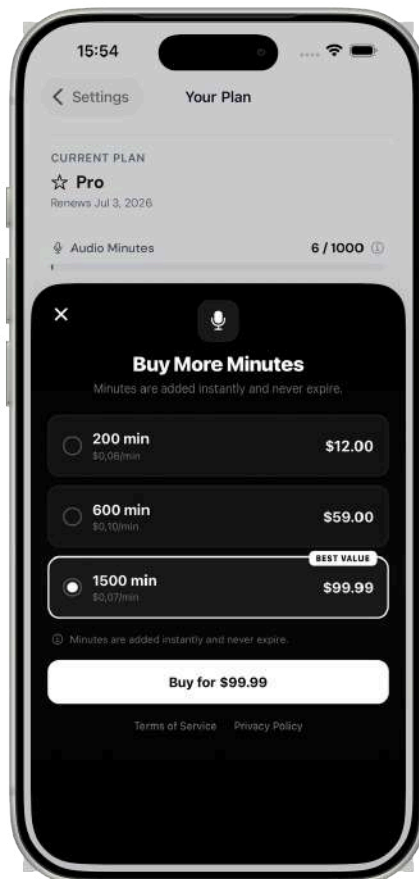

## 2.18.5 Redeem Code

1. Go to Settings -> Subscription -> Redeem Code.

2. Enter your code (from the XNote web store or promotional campaigns). Codes are automatically converted to uppercase.

3. Tap **"Redeem"**.

Codes can:

- Activate a plan (Pro, Unlimited, or Lifetime) for a specific duration
- Add audio minutes to your account

A confirmation message will show what was applied (plan name and duration, or number of minutes added). If the code is invalid or expired, an error message will explain the reason.

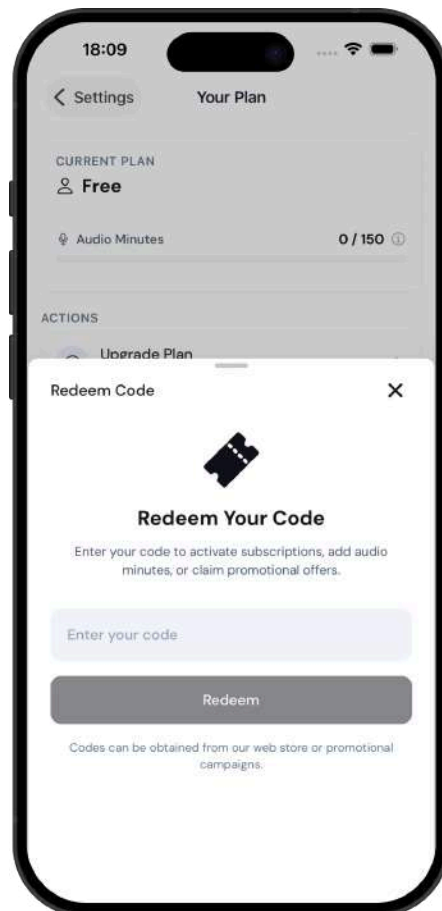

## 2.18.6 Manage & Restore

Manage Subscription:

Tap **"Manage Subscription"** to be redirected to the appropriate store:

- iOS : Opens App Store subscription management
- Android : Opens Google Play subscription management
- Shopify purchases : Opens [xnote.ai/account](https://xnote.ai/account)

From the store, you can change your billing period, upgrade/downgrade your plan, or cancel your subscription. Cancellation takes effect at the end of your current billing period you will continue to have access until then.

Restore Purchases:

If you previously purchased a subscription on a different account or reinstalled the app, tap **"Restore Purchases"**. XNote will check your Apple ID or Google Play account for active subscriptions.

If a subscription is found that doesn't match your current account:

- The **"Restore Purchases"** button will be highlighted
- A message shows which plan was found (e.g., **"Found Pro subscription on your Apple ID"**)
- A warning explains that restoring will transfer the subscription from your previous account
- After confirming, the subscription is transferred and your plan is updated

### 2.18.7 Subscription Timeline

Below the actions section, a timeline shows your full subscription history in reverse chronological order.

Subscription events show:

- Plan name with color-coded badge (Free = gray, Pro = purple, Unlimited = emerald, Lifetime = amber)
- Date range (start — end)
- Source (App Store, Google Play, Redeem Code)
- Status badge: **"Current"** (green), **"Renewed"** (blue), **"Cancelled"** (red), **"Expired"** (gray), **"Upgraded"** (green), **"Downgraded"** (orange)

Add-on events show:

- **"Audio Minutes"** label with operation type
- Operation badge: **"Redeemed"** (blue), **"App Store Purchase"** (blue), **"Refunded"** (red), **"Adjusted"** (gray)
- Date and minutes added (+) or removed (-)

Joined event: Shows your account creation date at the bottom of the timeline.

If you have more than 7 events, the timeline shows the 3 most recent with a **"Show All"** button to expand the full history. Tap **"Show Less"** to collapse.

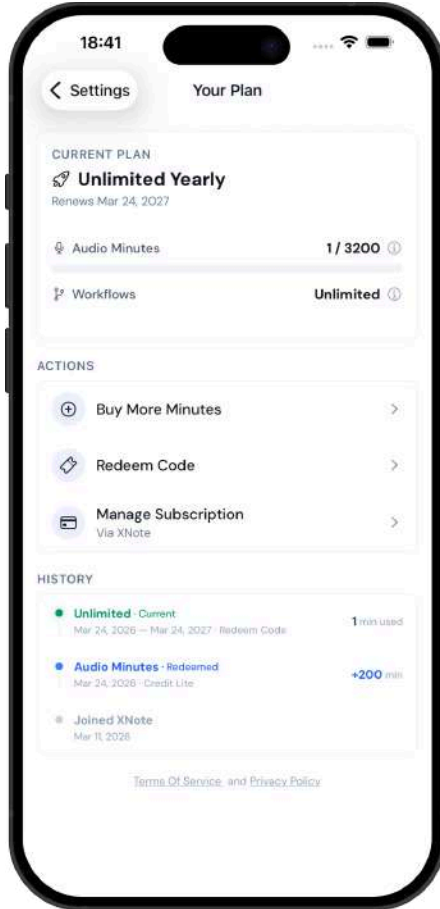

## 2.19 Stroke History

### 2.19.1 What is Stroke History?

Stroke History lets you travel through time on any page of your notebook. You can see when each

stroke was written, remove unwanted strokes, and move them to another notebook.

Common use cases:

- Strokes were accidentally imported to the wrong page via Offline Sync
- You want to clean up a page by removing certain sections
- You want to move strokes from one notebook to another



Stroke History main screen

## 2.19.2 How to Open

Open any notebook page. Then tap the clock icon in the header toolbar.



*Tap the clock icon in the notebook header to open Stroke History*

Stroke History opens for the current page only. Each page has its own independent history.

## 2.19.3 Understanding the Timeline

When you open Stroke History, you see all strokes on the current page rendered in a preview canvas.

### The Slider

The slider at the bottom represents the timeline:

- Right end = newest stroke (most recently written)
- Left end = oldest stroke (written first)
- Drag the slider left to go back in time

### +/- Buttons

Use the - and + buttons above the slider for precise control. Tap once to move one stroke at a time.

Hold down to move continuously.

### Time Labels

The timestamps below the slider show the time of the first and last stroke. If strokes span multiple

days, dates are shown (e.g.

"Apr 6, 11:30" instead of just "11:30:54").

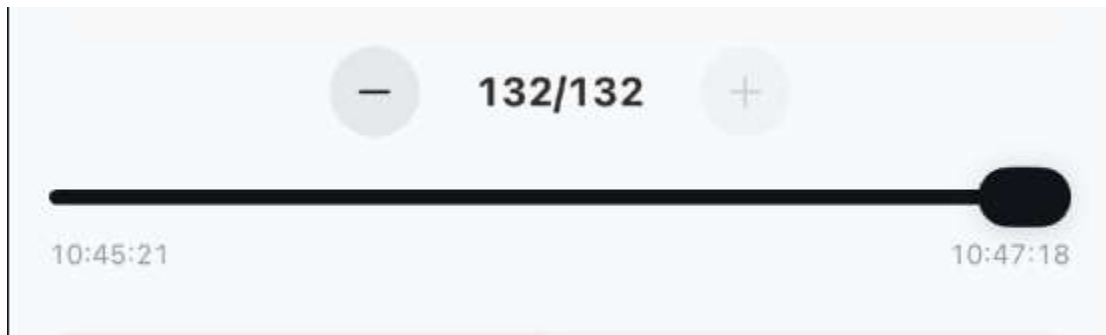

*Slider area: +/- buttons, stroke counter, and time labels*

## 2.19.4 Two Ways to Delete

At the bottom of the screen you see two mode buttons: Cut after and Range.

### 2.19.4a Cut After

This is the default mode. Move the slider to a point in time. Everything after that point appears in **red** and will be deleted.

Steps:

1. Drag the slider or use +/- buttons to find the point where unwanted strokes begin
2. Strokes after the slider turn red in the preview
3. Switch to the After Delete tab to see what the page will look like
4. Tap the red Delete button
5. A confirmation dialog appears review the message and tap Delete to confirm, or Cancel to go back



*Cut After mode strokes after the slider shown in red*

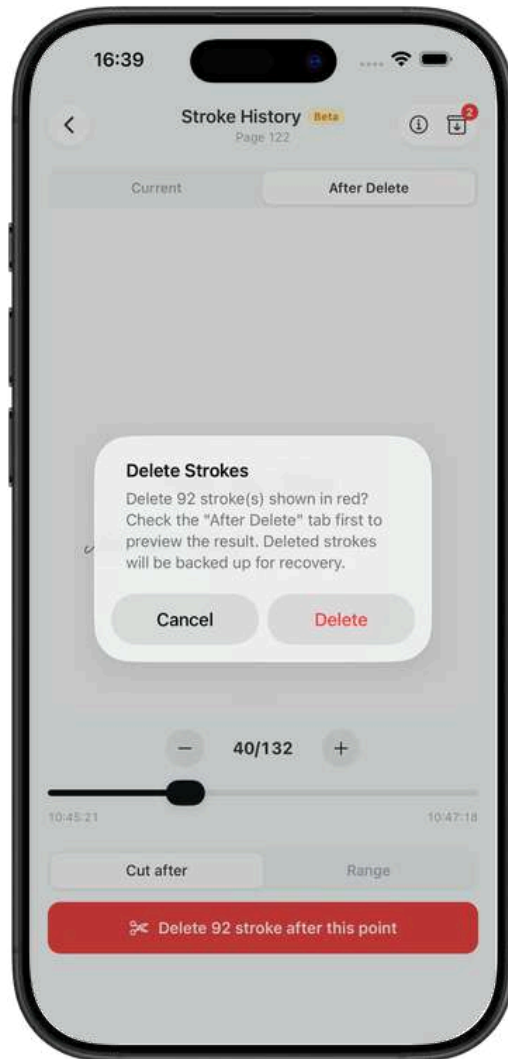

*Confirmation dialog deleted strokes will be backed up for recovery*

*Use this when: The unwanted strokes are at the end of the timeline. For example, strokes that were accidentally added after your own writing.*

## 2.19.4b Range Delete

Switch to Range mode to select a specific section to delete. Two draggable handles appear on the slider.

Steps:

1. Tap Range to switch modes
2. Drag the left handle to the start of the section you want to remove
3. Drag the right handle to the end of the section
4. The selected strokes appear in red in the preview
5. Use +/- buttons for precise adjustments of Start and End
6. Switch to After Delete tab to preview
7. Tap the red Delete button
8. A confirmation dialog appears tap Delete to confirm, or Cancel to go back



*Range mode two handles to select a section, with Start/End controls*

### 2.19.4c Use this when

Use this when: The unwanted strokes are in the middle of the timeline. For example, day 1 is correct, day 2 was accidentally imported, and day 3 is correct again. Range lets you remove only day 2.

### Repeated Wrong Imports

If strokes were accidentally imported to the wrong page multiple times at different intervals via Offline Sync, they will appear as separate layers in the timeline. In this case, you can use **Range** mode repeatedly to remove each unwanted import one by one. Identify each import segment in the

timeline, select it with the range handles, delete it, and then repeat for the next segment. Check the **After Delete** preview after each deletion to make sure you are only removing the unwanted strokes.

**- Important:** Be extra careful when working with older notes. Strokes written before the Stroke History update may not have accurate timestamps, which means the timeline order might not match the actual writing order. In such cases, the import segments may not be clearly separated in the timeline. Always use the After Delete preview to verify you are selecting the correct strokes before confirming deletion.

## 2.19.5 Preview Tabs

Two tabs at the top let you switch between views:

Tab	What it shows
Current	All strokes with the selected ones highlighted in red
After Delete	How the page will look after deletion (red strokes removed)



*Current red strokes visible*



*After Delete red strokes removed*

*Always check the After Delete tab before confirming deletion.*

## 2.19.6 Recovery

After cutting strokes, they are not permanently gone. They go to Recovery.

### Opening Recovery

Tap the archive icon in the top right corner of the Stroke History screen.

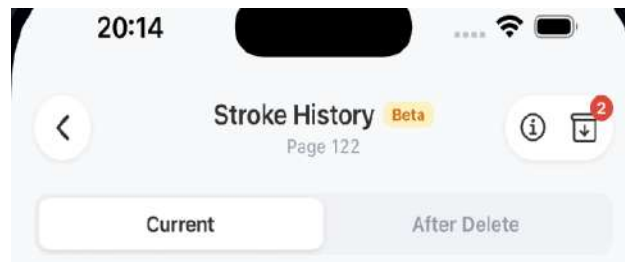

### Recovery List

Each deletion appears as a card showing:

- Number of strokes
- When they were deleted
- Timestamp of the original strokes

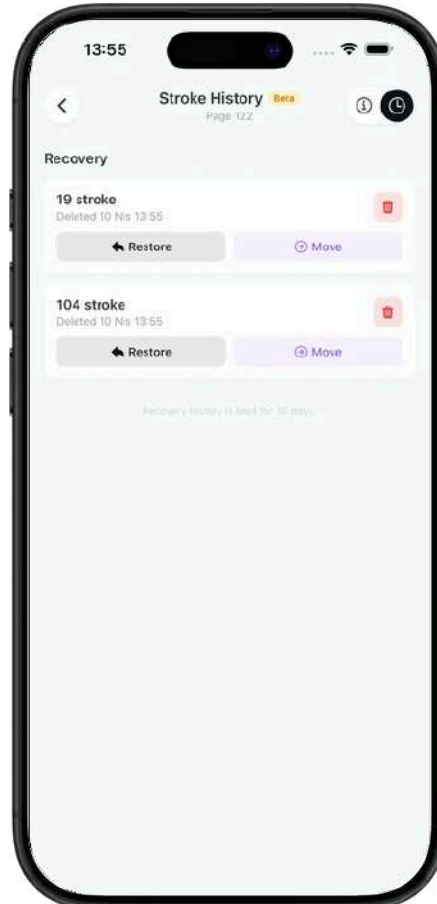

## Actions

Restore	Puts the strokes back on the original page
Move	Moves the strokes to the same page number in another notebook
Delete(trash icon)	Permanently removes the strokes. Cannot be undone

## 2.19.7 Moving Strokes to Another Notebook

To move strokes to another notebook, you first need to cut (delete) them from the current page.

Deleted strokes are automatically sent to **Recovery**, and from there you can move them to another notebook. The full workflow is:

1. Open Stroke History and use **Cut after** or **Range** mode to select the strokes you want to move
2. Tap the red **Delete** button and confirm in the dialog
3. The strokes are now in **Recovery** tap the archive icon to open it
4. Find the deletion card and tap Move

### Selecting the Target Notebook

Steps:

1. A list of notebooks appears, filtered to the same type as the source notebook (Standard, Mini, or Large). The source notebook is not shown.
2. Tap a notebook
3. A preview shows what the target page will look like with the moved strokes
4. Tap Move to confirm

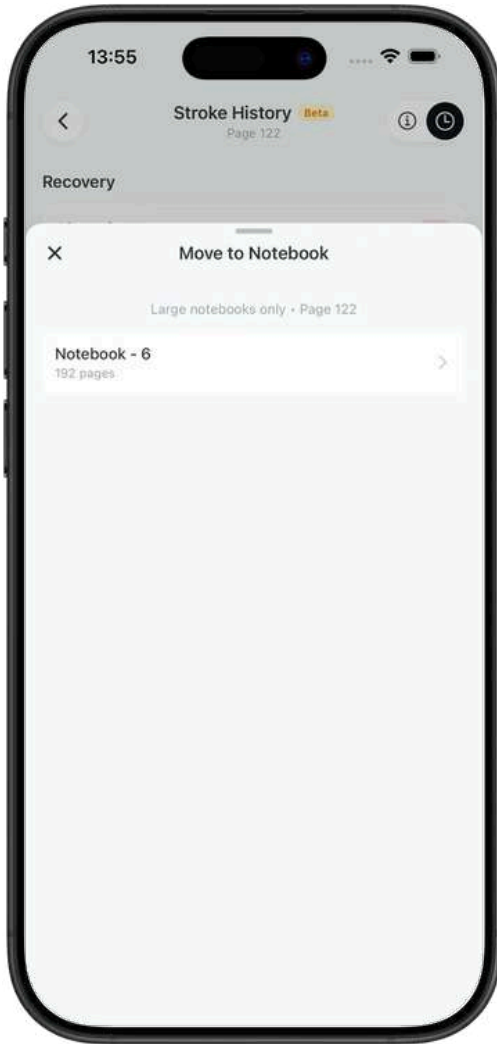

*Notebook selection list*



*Move preview existing + moving strokes*

### **After Moving**

**Source page Recovery:** Shows a "Moved" badge with the target notebook name and page number. Only the Delete button is available.

**Target page:** The strokes are now regular strokes on that page. You can view them in the target page's Stroke History.

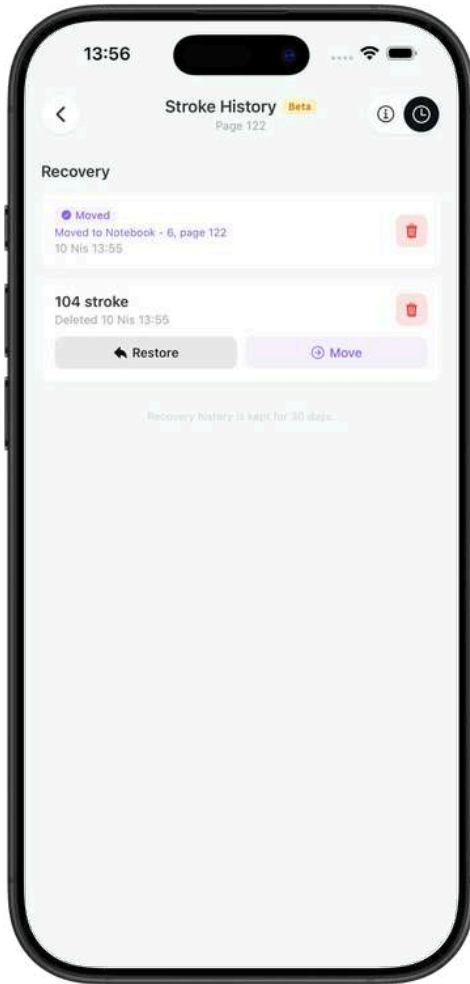

*Moved card in Recovery shows destination notebook and page*

## 2.19.8 Important Information

### Page-Specific

Stroke History works per page. Opening it on page 42 shows only the strokes on page 42.

### Same Notebook Type Only

When moving strokes, you can only move to notebooks of the same type (Standard to Standard, Mini to Mini, Large to Large). The strokes are always moved to the same page number as the source.

### 30-Day Recovery

Recovery history is stored locally on your device for 30 days. After 30 days, unrestored/unmoved strokes are automatically removed.

### Permanent Delete

If you tap the trash icon on a Recovery card, those strokes are gone forever. There is no undo. Beta Feature Stroke History is currently in beta. Strokes written recently have accurate timestamps and will display in correct order. Older strokes (imported before this update) may not have precise timestamps, so their order in the timeline might not be fully accurate.

### Old Notes Use with Caution

If you are working with older notebooks that contain strokes written before the Stroke History update, please proceed with extra caution. Since these strokes may lack accurate timestamps, the timeline may not reflect the true writing order. This can make it difficult to distinguish between your own strokes and accidentally imported ones. Always review the **After Delete** preview carefully before confirming any deletion, and consider using **Recovery** to restore strokes if you accidentally remove the wrong ones.

**App Uninstall Warning:** If you uninstall the app or clear app data, all Recovery history is permanently lost. Active strokes on your pages are safe (they sync to the cloud), but Recovery data is local only.

## 2.19.9 Quick Reference

Open Stroke History	Clock icon in notebook header
Go back in time	Drag slider left or tap -
Delete after a point	Use <b>Cut after</b> mode, tap red button
Delete a section	Use <b>Range Mode</b> , set handles, tap red button
Preview result	Switch to <b>After Delete</b> tab
Recover deleted strokes	Tap archive icon, then <b>Restore</b>
Move to another notebook	Tap archive icon, then <b>Move</b> on card
Permanently delete	Tap trash icon on a Recovery card
View guide again	Tap info (i) in header

## 2.19.9 FAQ

### **Q: I deleted strokes by mistake. Can i get them back ?**

Yes, go to Recovery (archive icon) and tap Restore. This works for 30 days after deletion.

### **Q: Why can't I see some notebooks in the Move list?**

Only notebooks of the same type (Standard/Mini/Large) that are not deleted are shown. The current notebook is also excluded.

### **Q: Why are the strokes in a different order than I wrote them?**

Strokes imported before this update may not have precise timestamps. Recently written strokes will have correct ordering.

### **Q: What happens to tasks and events extracted from a page when I delete all strokes?**

The page content (OCR text) is cleared, but previously extracted tasks and events remain untouched. If you restore the strokes, a new processing will run and update them.

*This feature is in Beta. We are actively improving timestamp accuracy and the overall experience.*

## 2.20 Notification Settings

This is the Notification Settings screen of an audio recording/transcription app.

This is the **Notification Settings** screen of an audio recording/transcription app. Here's the summary:

### Recording Notifications

- **Recording Processed:** Notifies you when your recording has been transcribed and summarized
- **Transcription Only:** Notifies you when transcription is done but summary generation failed
- **Processing Failed:** Notifies you when recording transcription fails entirely

### Quota Notifications

- **Audio Limit Reached:** Notifies you when you run out of audio minutes
- **Audio Limit Low:** Notifies you when your audio minutes are running low
- **Auto-Process Skipped:** Notifies you when auto-processing is skipped due to insufficient quota

### Account Notifications

- **Account Deletion:** Notifies you about scheduled account deletion

All options are currently **enabled (green/toggled on)**.

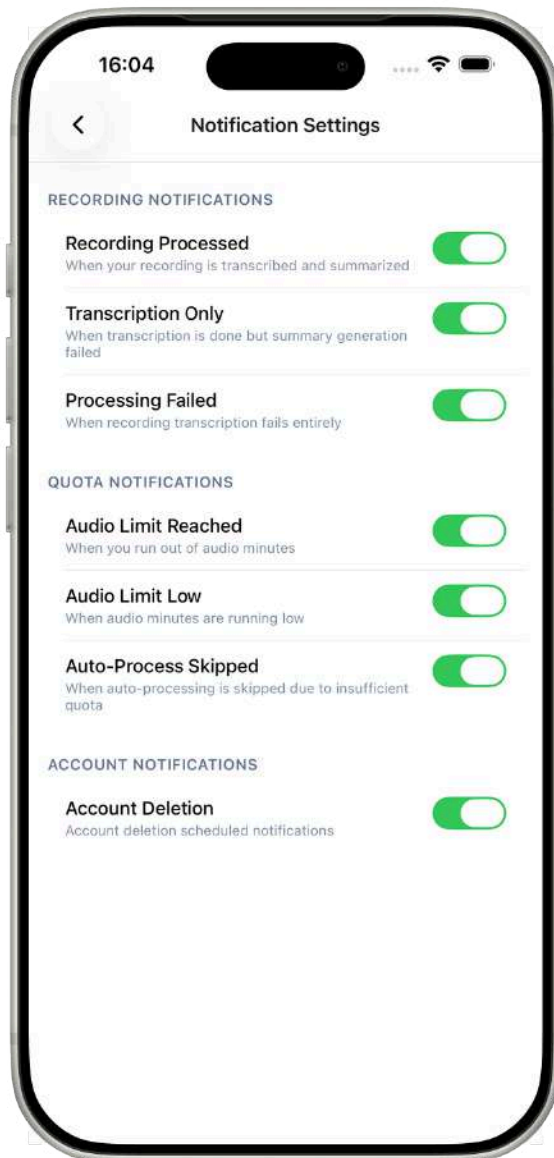

## 2.21 Inbox

The Inbox (accessed from Settings) is where surveys and announcements are delivered to the user. The logic: items appear here as cards. A user can interact with an item, and even if it's dismissed, it isn't lost the user can re-enter the Inbox, view the item again, respond to it, and mark it as completed. Items are organized by status, so the user can track which ones they've already handled versus which are still pending.

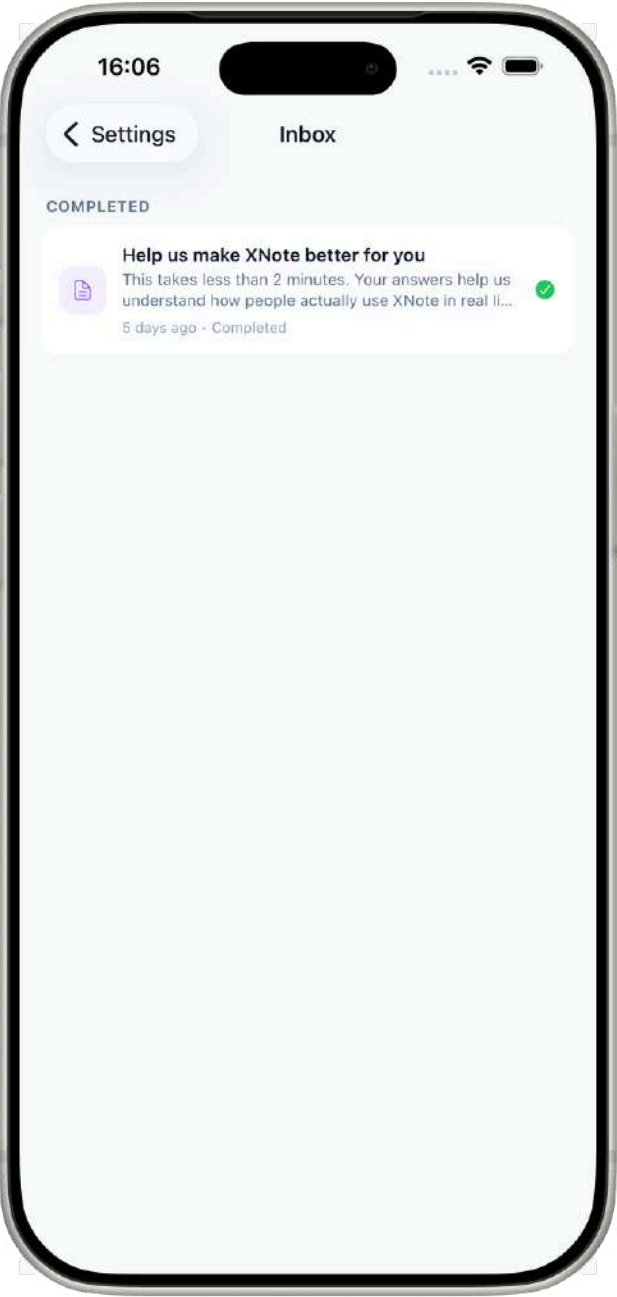

## 2.22 Customize

This is the Customize screen, where the user personalizes the app's navigation by arranging which sections appear in the tab bar versus the More menu. This is the Customize screen, where the user personalizes the app's navigation by arranging which sections appear in the tab bar versus the More menu. The logic: Home is permanently pinned (shown with a lock icon) and can't be moved.

The remaining items are grouped into "In Tab Bar" and "More Menu." Whichever items the user places at the top get the tab bar slots, while the rest live inside the More menu. The user reorders items by long-pressing and dragging them, and the layout updates based on their chosen priority so they decide which sections are most accessible.

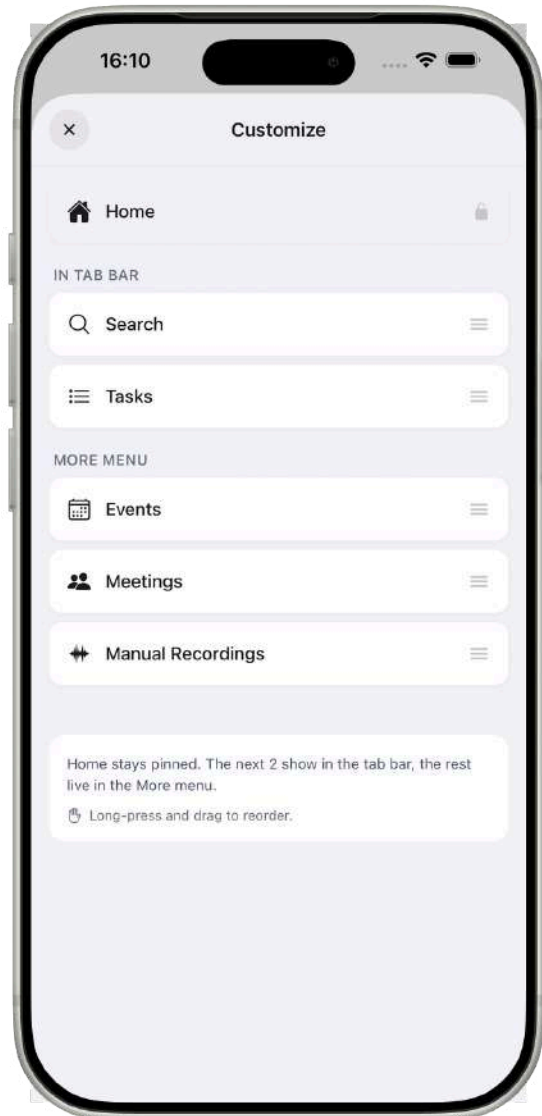
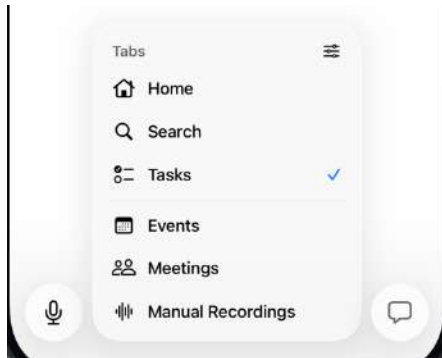

# 3. XNote Web

XNote Web provides the same core features as the mobile app, accessible from your browser.

## 3.1 Open XNote Web

Open XNote Web by navigating to the XNote web address in your browser.

**https://web.xnote.ai**

The landing page features a two-column layout on desktop:

- Left side: Dark branded area with the XNote logo, tagline **"Capture ideas. Effortlessly."**, and feature highlights (Voice Recording, Smart Notes, Handwriting, AI Powered). Links to Terms of Service and Privacy Policy are shown at the bottom.
- Right side: Authentication form area (sign up or sign in).

On mobile screens, the layout switches to a single column with the form only.

Browser requirement: Chrome, Edge, or Opera is recommended for full functionality, including Bluetooth pen pairing via the Web Bluetooth API. Safari does not support Web Bluetooth.

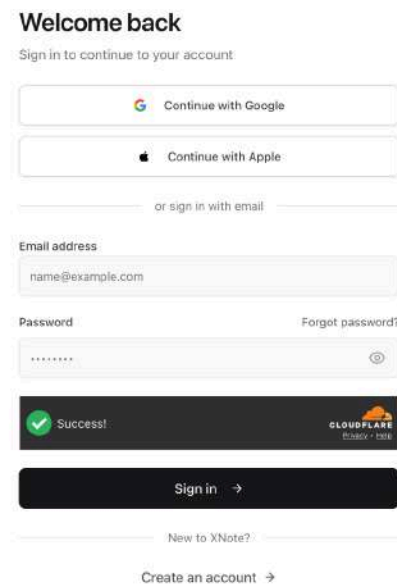
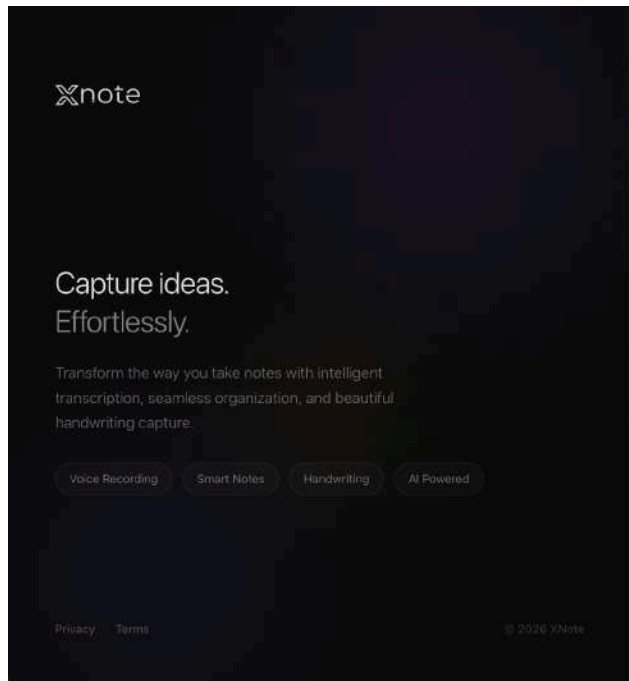

## 3.2 Account & Authentication

From the landing page, you can create a new account or sign in to an existing one.

### 3.2.1 Sign Up (Create an Account)

There are three ways to create an XNote account:

- Email
- Continue with Google
- Continue with Apple

#### Sign Up with Email:

1. Click "Create an account"

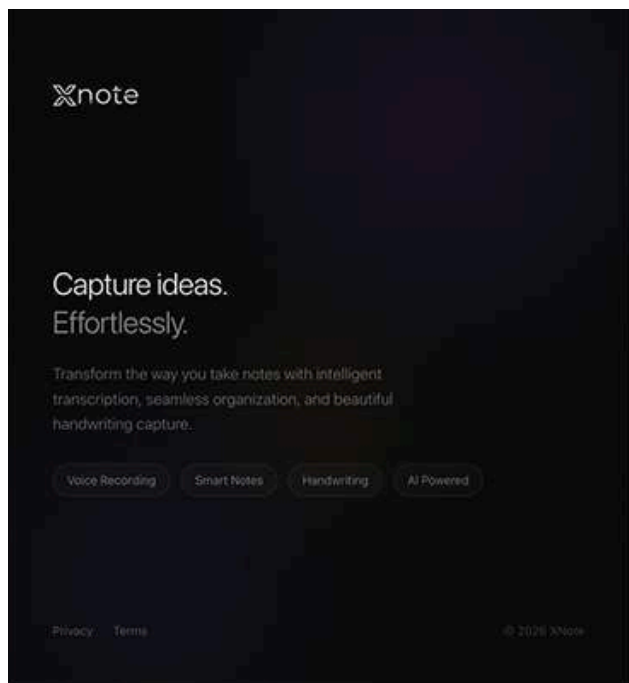

#### Welcome back

Sign in to continue to your account.

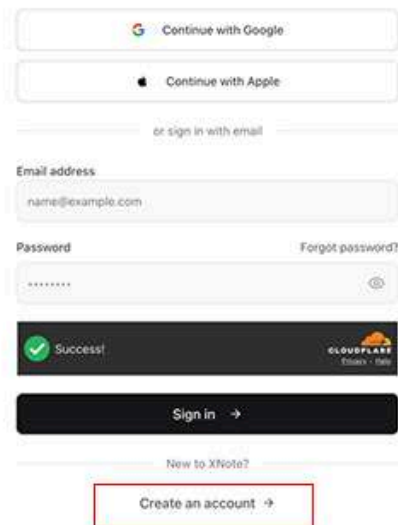
The image shows a sign-in form. It has two buttons for social login: "Continue with Google" and "Continue with Apple". Below these is a link "or sign in with email". There are two input fields: "Email address" (with the placeholder "name@example.com") and "Password" (with a "Forgot password?" link). A "Success" message is displayed in a dark box with a green checkmark and the Cloudflare logo. Below the success message is a "Sign in" button with a right arrow. At the bottom, there is a link "New to XNote?" and a "Create an account" button with a right arrow, which is highlighted with a red box.

2. Enter your email address and create a password. Re-enter your password to confirm.

Password requirements (shown with real-time checkmarks as you type):

- At least 8 characters
- At least one uppercase letter (A-Z)
- At least one lowercase letter (a-z)
- At least one number (0-9)
- At least one special character

3. Complete the Cloudflare Turnstile verification (a brief security check that appears below the form).

4. Click **"Sign Up"**.

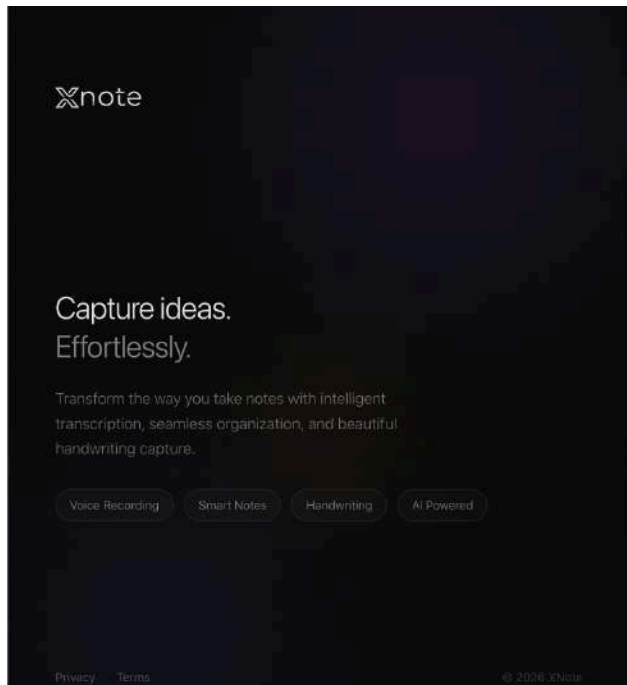

## Create your account

Start your journey with XNote today

Email address

name@example.com

Password

Create a strong password

Confirm password

Confirm your password

Success!



Create account →

By creating an account, you agree to our [Terms of Service](#) and [Privacy Policy](#)

or continue with

Continue with Google

Continue with Apple

Already have an account?

5. A 6-digit verification code will be sent to your email. Enter the code on the verification page.
- Each digit has its own input field. The cursor moves automatically as you type.
  - You can paste a full 6-digit code directly.
  - If you didn't receive the code, click "**Resend**" after the 60-second countdown.
  - The code expires after a limited time. If it expires, request a new one.

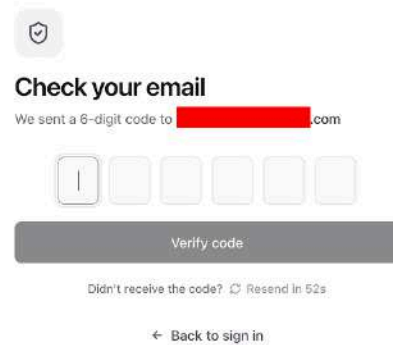
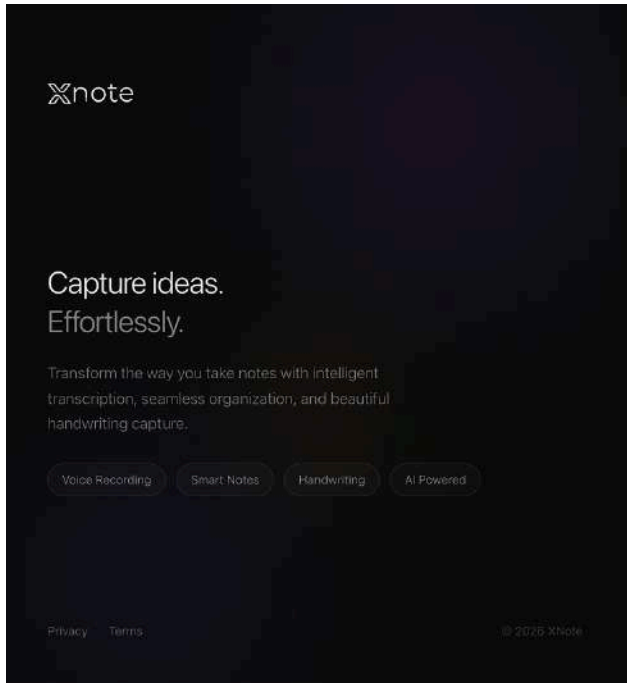

After successful verification, you will be redirected to the Onboarding steps [\(see 3.3\)](#).

## Sign Up with Google:

Click "**Continue with Google**". Select your Google account. Once authenticated, you will be redirected to the Onboarding steps.

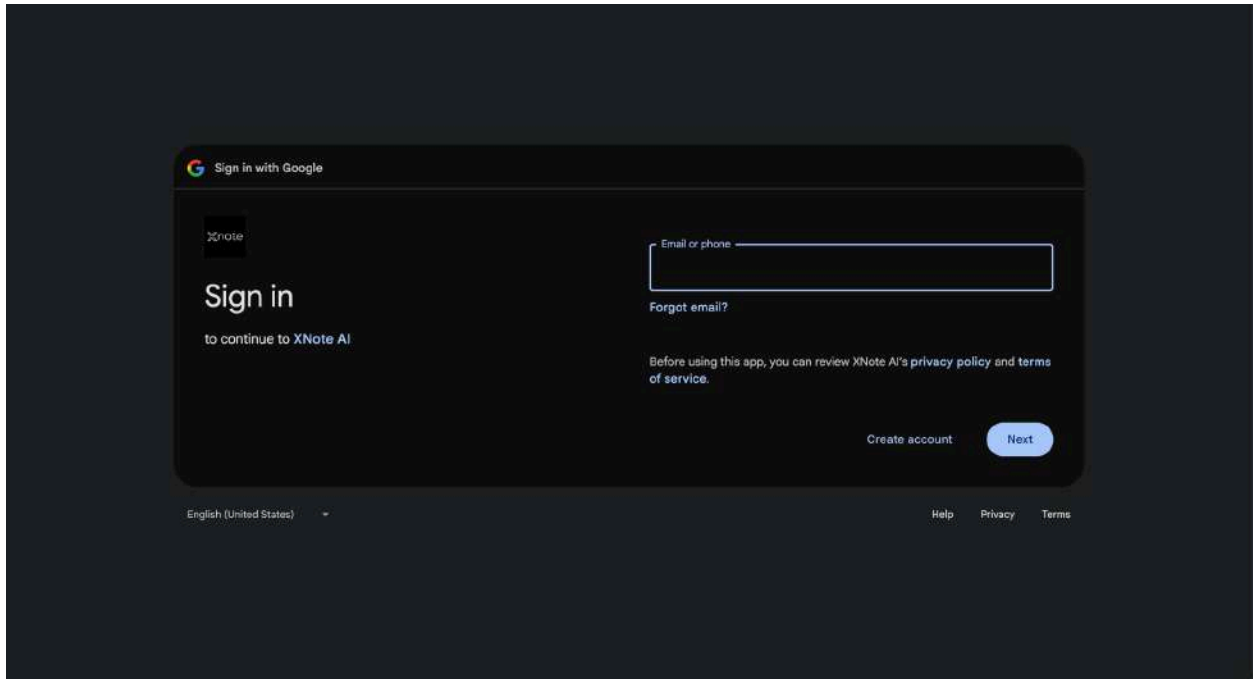

## Sign Up with Apple:

Click **"Continue with Apple"**. Confirm with your Apple ID. Once authenticated, you will be redirected to the Onboarding steps.

 **Apple Account** Sign in

---



Use your Apple Account to sign in to XNote.



In setting up Sign in with Apple, information about your interactions with Apple and this device may be used by Apple to help prevent fraud. [See how your data is managed...](#)

Continue Sign in with Passkey

Requires a device with iOS 17 or later.

### 3.2.2 Sign In (Existing Account)

If you already have an account, click **"Sign in instead"** at the bottom of the sign-up form, or navigate to the sign-in page directly.

Sign In with Email:

1. Enter your email address and password.
2. Complete the Cloudflare Turnstile verification.
3. Click **"Sign In"**.

If your email has not been verified yet, you will be redirected to the OTP verification page to confirm your email first.

Sign In with Google:

Click **"Continue with Google"** on the sign-in page. Select your Google account. If the account exists, you will be signed in directly.

Sign In with Apple:

Click **"Continue with Apple"** on the sign-in page. Confirm with your Apple ID.

After signing in, XNote checks your onboarding status:

- If onboarding is incomplete, you will be redirected to the appropriate onboarding step.
- If onboarding is complete, you will be taken directly to the Home dashboard.

Note: Unlike the mobile app, there is no Initial Sync screen on web. Your data is loaded automatically in the background.

### 3.2.3 Forgot Password

If you forgot your password:

1. On the Sign In page, click **"Forgot password?"** (located next to the password label).
2. Enter your email address and click **"Send verification code"**. A 6-digit OTP code will be sent to your email.

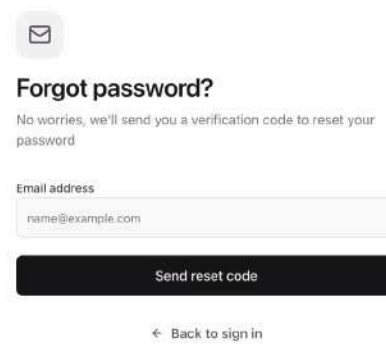
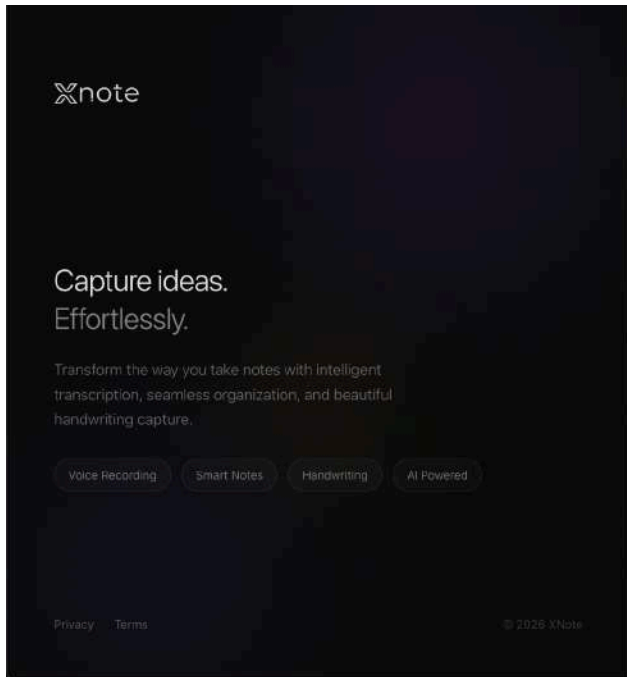

3. Enter the 6-digit code on the verification page. The same OTP input is used (auto-focus, paste support, 60-second resend cooldown).

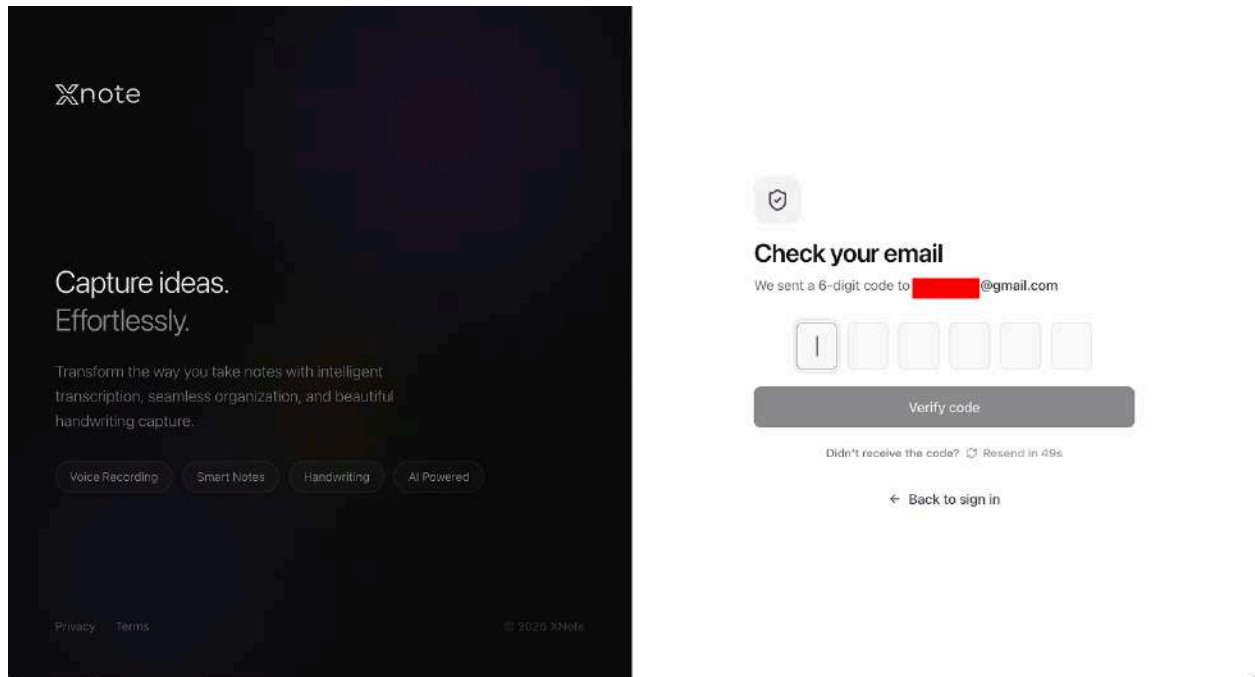

4. After successful verification, a "Set new password" page appears. Enter your new password and confirm it. The same password requirements apply (8+ characters, uppercase, lowercase, number, special character), shown with real-time validation indicators.

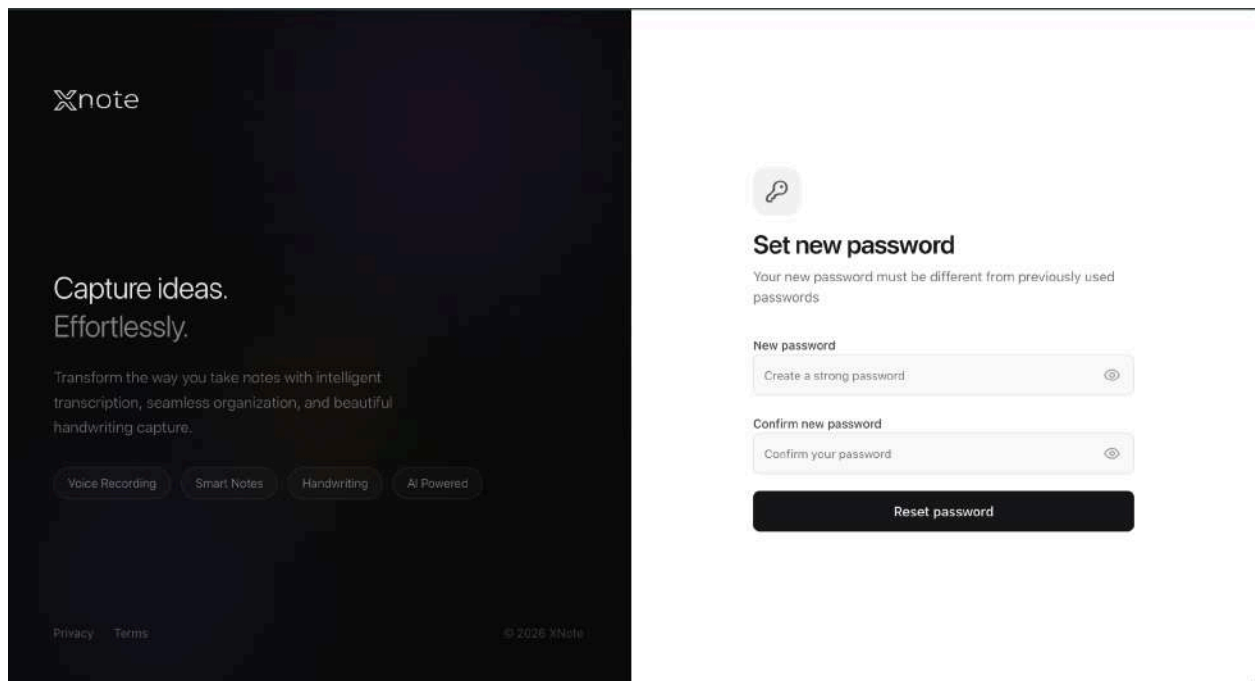

5. After changing your password, you will be redirected to the Sign In page. Log in with your new password.

Tips:

- Check your spam/junk folder if you don't receive the code
- You can request a new code after a 60-second cooldown
- The OTP code is only valid for a limited time

## 3.3 Onboarding (Language, Handedness, Preferences)

After creating your account, XNote guides you through a personalized setup. A progress bar at the top of each step shows your current position.

### Step 1 : Enter Your Name

Enter your full name. A minimum of 2 characters is required.

1/6

#### What should we call you?

To give you a personalized experience, please tell us your name.

Full Name

Continue





















## Step 2 : Select Writing Language

Choose your writing language from a grid of 25 supported languages with flag emojis. Languages are displayed in a 3-column grid layout. Use the search bar at the top to filter by English name or native name. Your browser language is auto-detected as the default.

2 / 0

### What language do you write in?

Helps us optimize handwriting recognition for you.

 English ✓	 Español	 Português
 Nederlands	 Türkçe	 Deutsch
 Français	 Italiano	 Polski
 Svenska	 Norsk	 Dansk
 Suomi	 Русский	 Українська
 Čeština	 Română	 Magyar
		

### Step 3 : Select Handedness

Choose whether you are left-handed or right-handed. The two options are displayed as large cards with hand emoji icons in a 2-column layout. A checkmark badge appears on the selected option.

Note: Unlike the mobile app, there is no Mirror Writing option on web. Mirror Writing is a mobile-only feature ([see 2.7.1](#)).

3 / 6

#### Which hand do you write with?

Helps us optimize pen detection for you.



Left-handed



Right-handed

< Back

Continue >







## Step 4 : Main Purpose

Select your primary reason for using XNote. Six options are displayed in a 2-column grid:

- Student (classes, exams)
- Entrepreneur (ideas, meetings)
- Professional (tasks, planning)
- Creative (journal, sketches)
- Healthcare (patient records)
- Educator (lessons, grades)

4 / 6

Which one describes you best?

<b>Student</b> (classes, exams) 	<b>Entrepreneur</b> (ideas, meetings) 
<b>Professional</b> (tasks, planning) 	<b>Creative</b> (journal, sketches) 
<b>Healthcare</b> (patient records) 	<b>Educator</b> (lessons, grades) 

[< Back](#) [Continue](#)

## Step 5 : Note Types

Select one or more note types that describe how you plan to use XNote. 18 options are displayed as selectable chips/tags in a wrapping layout. You can select multiple types.

Options include: Work Notes, Reading Notes, Academic Notes, Journaling, Daily Planning, Ideas & Thoughts, Meeting Notes, Project Notes, Creative Writing, Research Notes, Travel Notes, Health & Fitness, Language Learning, Goal Setting, Recipe Notes, Book Reviews, Technical Documentation, Personal Reflections.

5/8

### What kind of notes do you typically take?

You can choose more than one

Work Notes

Reading Notes

Academic Notes

Journaling

Daily Planning

Ideas & Thoughts

Meeting Notes

Project Notes

Creative Writing

Research Notes

Travel Notes

Health & Fitness

Language Learning

Goal Setting

Recipe Notes

Book Reviews

Technical Documentation

Personal Reflections

< Back

Complete

## Step 6 : Note Frequency

Select how often you take notes. Five options are displayed in a vertical stack, each with an icon:

- Multiple times a day
- Once a day
- A few times a week
- Once a week
- Occasionally

6 / 6

### How often do you take notes?

Help us understand your note-taking habits.

The screenshot shows a mobile application interface for selecting note-taking frequency. The title is "How often do you take notes?" with a subtitle "Help us understand your note-taking habits." Below the title are five radio button options, each with an icon and text: "Multiple times a day" (with a lightning bolt icon), "Once a day" (with a sun icon), "A few times a week" (with a calendar icon), "Once a week" (with a clock icon), and "Occasionally" (with a leaf icon). At the bottom of the screen are two buttons: "Back" with a left arrow and "Continue" with a right arrow.

After completing these steps, you will proceed to Pen Setup to connect your XNote Smart Pen [\(see 3.4\)](#).

## 3.4 Pair Your Pen (Bluetooth Connection)

XNote Web supports pen pairing via the Web Bluetooth API. This step appears after completing the onboarding flow, and you can also access pen connection from the sidebar at any time ([see 3.6.1](#)).

Browser requirement: Chrome, Edge, or Opera is required. If your browser does not support Web Bluetooth, a warning message will appear: **"Web Bluetooth is not supported in this browser. Please use Chrome, Edge, or Opera."**

### Step 1 : Prepare Your Pen

A visual guide shows you three preparation steps with images:

1. Remove the cap to turn on your XNote Smart Pen
2. Enable Bluetooth on your computer
3. Make sure the pen nib is properly attached

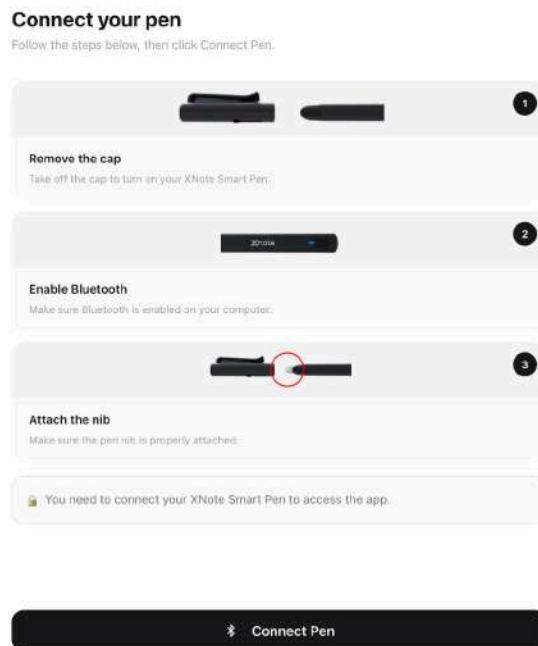

## Step 2 : Connect Your Pen

Click **"Connect Pen"**. Your browser will show a native Bluetooth device picker dialog. Select **"XNote Smart Pen"** from the list.

While connecting, the button changes to **"Connecting..."** with a loading spinner. The page title updates to **"Connecting..."** with a message: **"Select your XNote Smart Pen from the browser popup."**

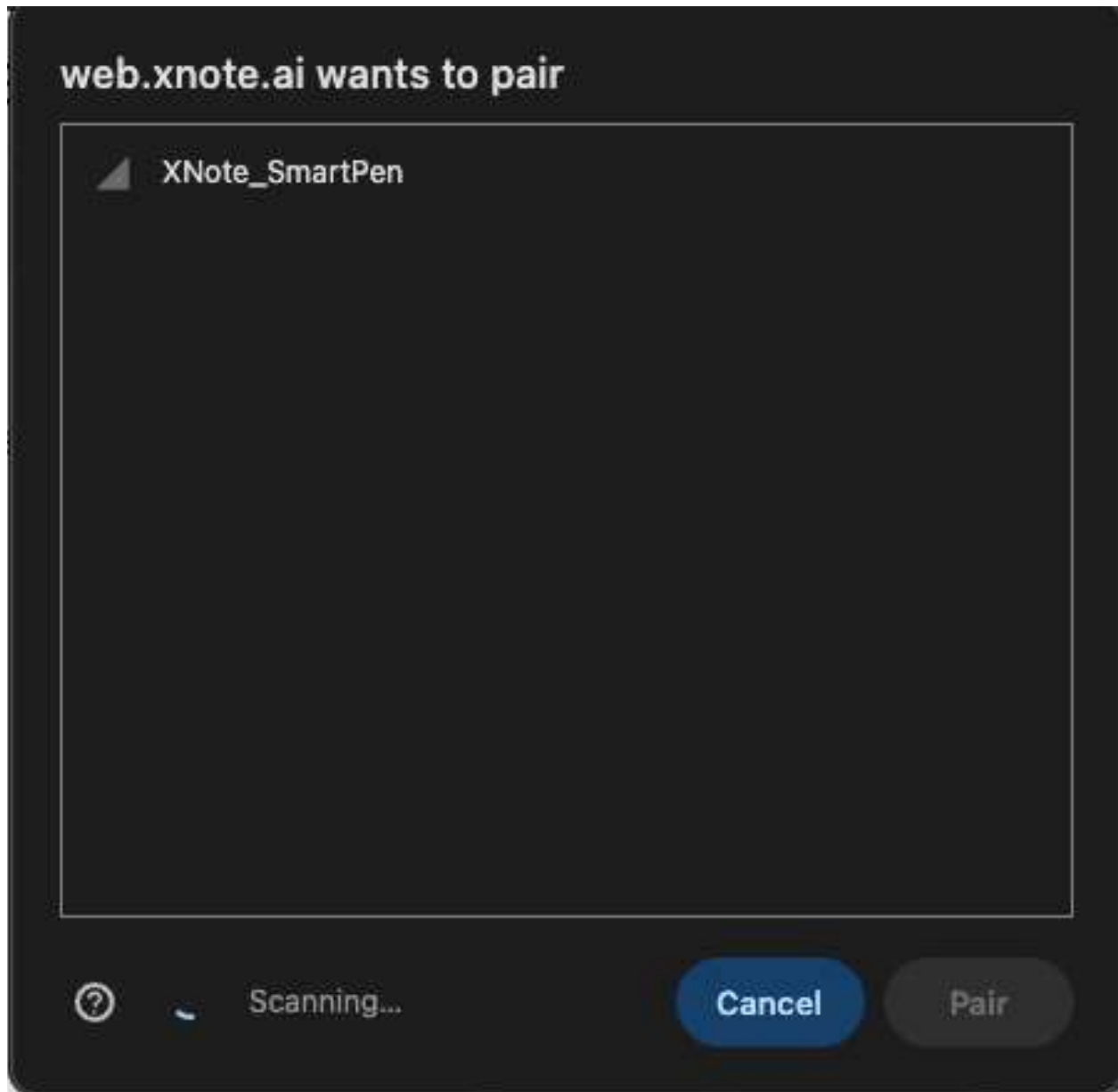

### **Step 3 : Connected**

A green checkmark confirms the connection is successful. The page shows **"Pen connected!"** with the message **"Your XNote Smart Pen is ready to use."** You will be automatically redirected to the Home dashboard.

If connection fails:

The page shows **"Connection failed"** with an error message. Click **"Try Again"** to restart the scanning process. Make sure your pen is turned on and nearby.

Note: Your pen can only be connected in one browser tab at a time. If the pen is already connected in another tab, you will see an error. Close the other tab or disconnect the pen there first.

## 3.5 Set Your Primary Notebook

The XNote Smart Pen uses dot patterns on each page to identify your writing. Since notebooks of the same size share identical dot patterns, you need to set a primary notebook for each size so the pen knows where to save your notes.

There are three primary notebook slots:

- Mini (small notebooks)
- Standard (standard notebooks)
- Large (large notebooks)

When you write with your smart pen, your notes will be saved to the primary notebook of the matching size.

How to set a primary notebook:

- From the Home page: Click the star icon on any notebook card. A filled blue star indicates the current primary. Click the star on a different notebook to change the primary.

The screenshot shows the XNote web interface. At the top, there's a navigation bar with 'xnote web' and several utility buttons like 'xnote min', 'Upgrade', 'Start Recording', and a user profile icon. Below the navigation bar, the main content area is titled 'Good Afternoon, Store!' and indicates 'You have 5 notebooks'. A notification banner asks 'What is a Primary Notebook?' and explains that users can set a primary notebook for each size (Mini, Standard, Large) and that notes are saved to the primary notebook of that size. Below the notification, there are two tabs: 'Notebooks' and 'Folders'. The 'Notebooks' tab is active, showing five notebook cards: 'Large Notebook - 1', 'Mini Notebook - 2', 'Standard Notebook - 3', 'Standard Notebook - 4', and 'Mini Notebook - 5'. Each card has a star icon in the top right corner. The star on 'Mini Notebook - 2' is filled blue, indicating it is the primary notebook. The star on 'Standard Notebook - 4' is outlined in red, indicating it is the current selection. Below the notebook cards, there are two buttons: 'New Notebook' and 'View All 5 notebooks'. To the right of these buttons is a 'Connect Calendar' button. Below the notebook cards, there is a section for 'Recent Meetings' with 0 recordings. At the bottom, there are three options to create recordings: 'Record on phone', 'Auto-record from calendar', and 'Send a bot'. The bottom status bar shows 'Pen Connected' and 'XNote Smart Pen'.

- From Settings: Go to Settings -> Primary Notebooks and use the dropdown selectors for each size.

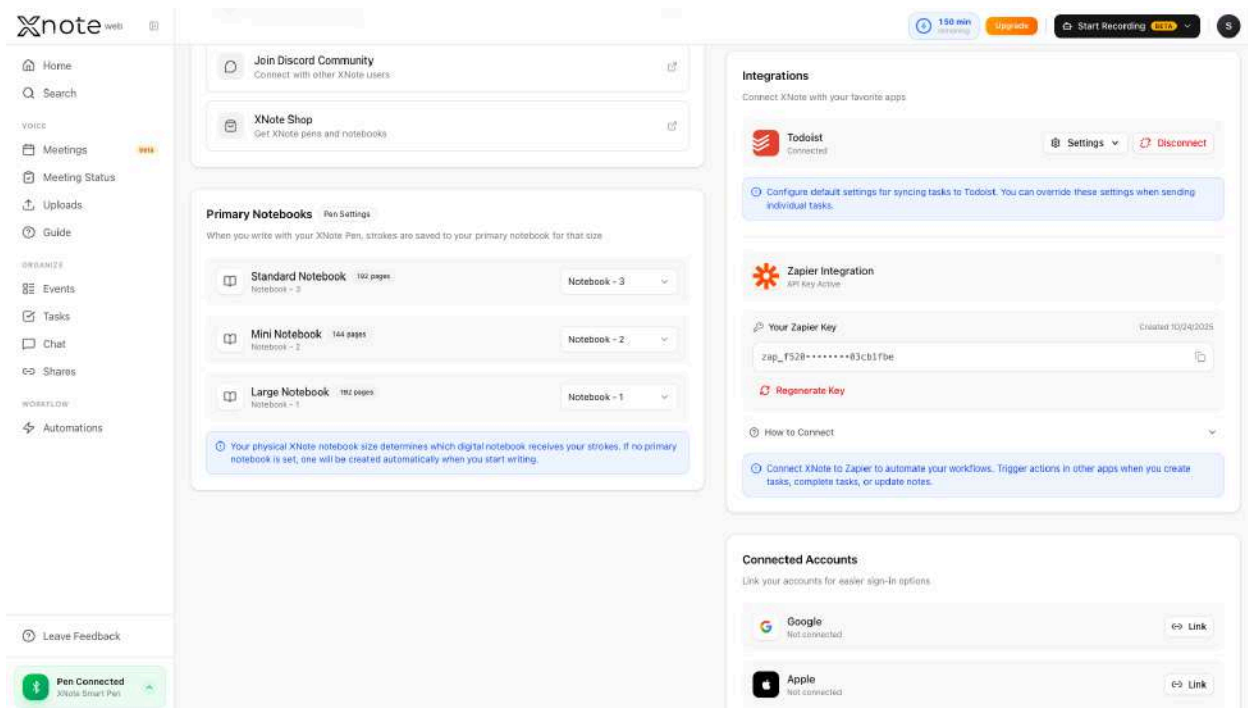

If you have multiple notebooks of the same size without a primary set, a mandatory selection modal will appear on the Home page prompting you to choose one. You must select a primary before continuing.

If you create your first notebook of a size, it will automatically be set as your primary notebook.

If you delete a primary notebook, XNote will automatically assign another notebook of the same size as primary.

An info banner on the Home page explains: **"When you write with your smart pen, your notes will be saved to the primary notebook of that size."** This banner can be dismissed and will not appear again.

## 3.6 Home

The Home dashboard is the main screen of XNote Web. It features a time-based greeting with your name (e.g., **"Good Morning, John"**), notebook/folder tabs with count badges, and sections for recordings, tasks, and upcoming events.

The top bar above the dashboard shows your remaining audio minutes (e.g. "150 min remaining") with a + Buy shortcut and a Share Feedback link. The Start Recording (BETA) button opens a menu with Add to live meeting (send a bot to a meeting that's happening now) and Schedule new meeting (set up a bot for an upcoming meeting); a direct in-browser Start recording option is marked Soon. Your account menu is at the far right.

On larger screens, the **Note Taker** panel on the right shows your meeting settings and upcoming/recent meetings ([see 3.6.7](#)).

The **left sidebar** is grouped into **Voice**, **Organize**, and **Workflow** sections for navigation ([see 3.6.1](#)).

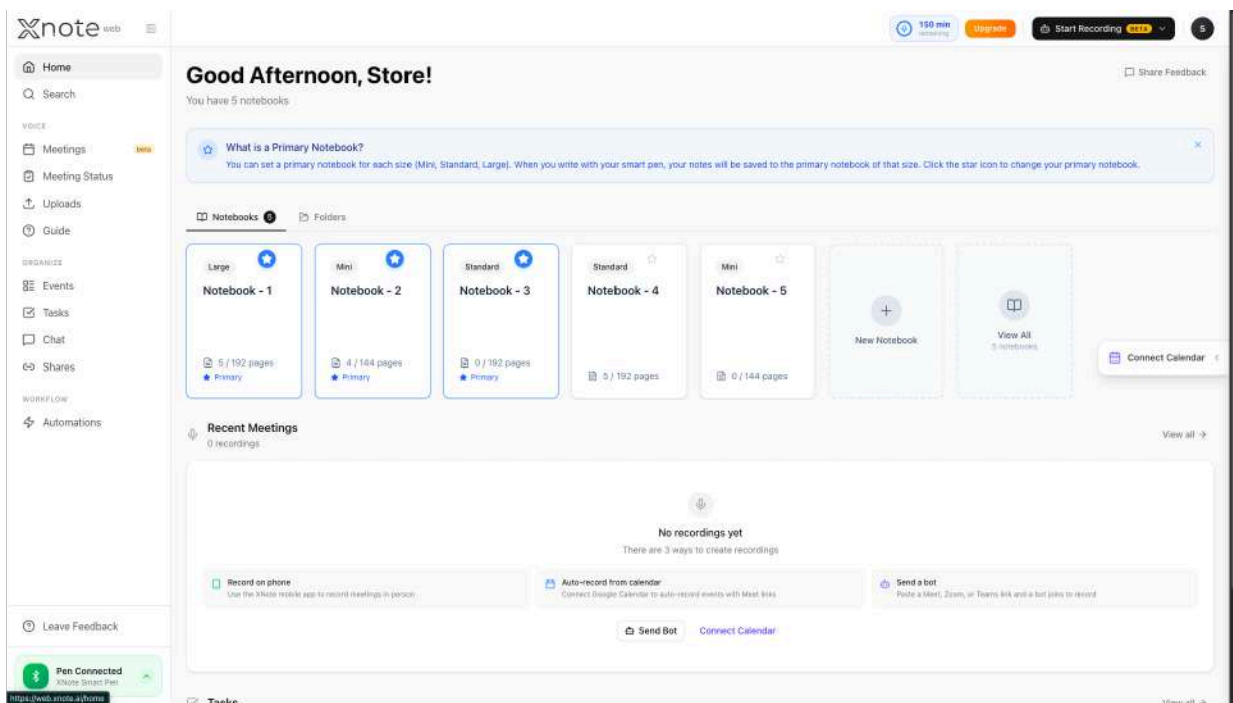

### 3.6.1 Sidebar & Pen Connection

The left sidebar is always visible and is organized into labeled groups so related features stay together:

- (Top): Home and Search.
- Voice: Meetings, Meeting Status, Uploads, and Guide.
- Organize: Events, Tasks, Chat, and Shares.
- Workflow: Automations.

A red live indicator appears next to Meeting Status while a recording bot is active. The table below maps each menu item to the section that documents it:

Group	Menu item	Documented in
—	Home	<a href="#">3.6</a>
—	Search	<a href="#">3.11</a>
Voice	Meetings beta	<a href="#">3.9</a>
	Meeting Status	<a href="#">3.9.8</a>
	Uploads	<a href="#">3.9.9</a>
	Guide	<a href="#">3.9.10</a>
Organize	Events	<a href="#">3.13</a>
	Tasks	<a href="#">3.12</a>
	Chat	<a href="#">3.10</a>
	Shares	<a href="#">3.16.3</a>
Workflow	Automations	<a href="#">3.14</a>

At the bottom of the sidebar, a Pen Connection button shows the current status of your XNote Smart Pen.

Pen Connection States:

- Disconnected: A blue gradient button labeled "**Connect Pen**". Click to start scanning for your pen via Web Bluetooth ([see 3.4](#)).

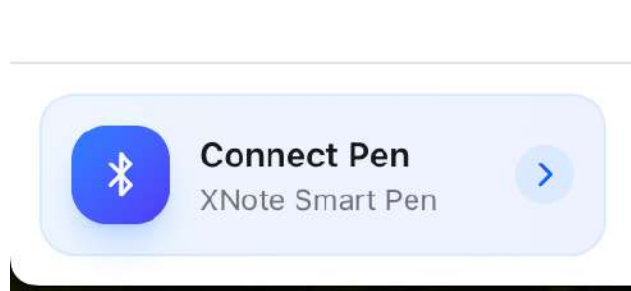

- Connecting: The button shows a pulsing animation with a spinner icon and is disabled during the connection process.

- Connected: A green gradient button labeled **"Pen Connected"** with **"XNote Smart Pen"** subtitle. Click to expand a dropdown panel showing pen details and settings.

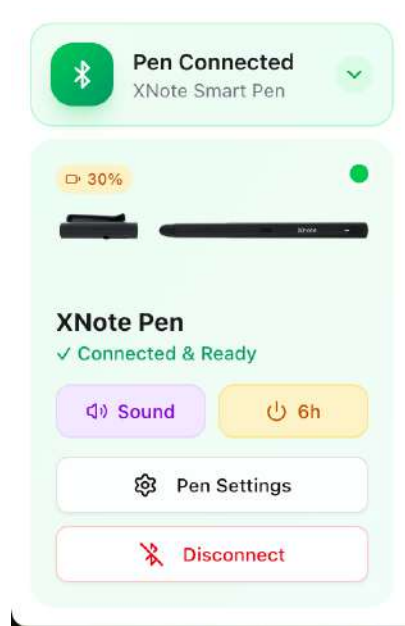

When connected, clicking the pen button opens a dropdown panel below it where you can view pen information and access pen settings ([see 3.8.1](#)).

Note: On mobile-width screens, the sidebar collapses to a narrow icon-only bar (64px). The pen button is hidden on mobile-width screens.

### 3.6.2 Notebooks View

Notebooks are displayed as a responsive grid of cards. Each card shows:

- Notebook type badge (Mini / Standard / Large)
- Title
- Page count (e.g., "**24 / 192 pages**")
- Primary star icon (filled blue if primary, hollow if not)
- Pin indicator (blue border and ring if pinned)

Pinned and primary notebooks appear first in the grid, followed by most active.

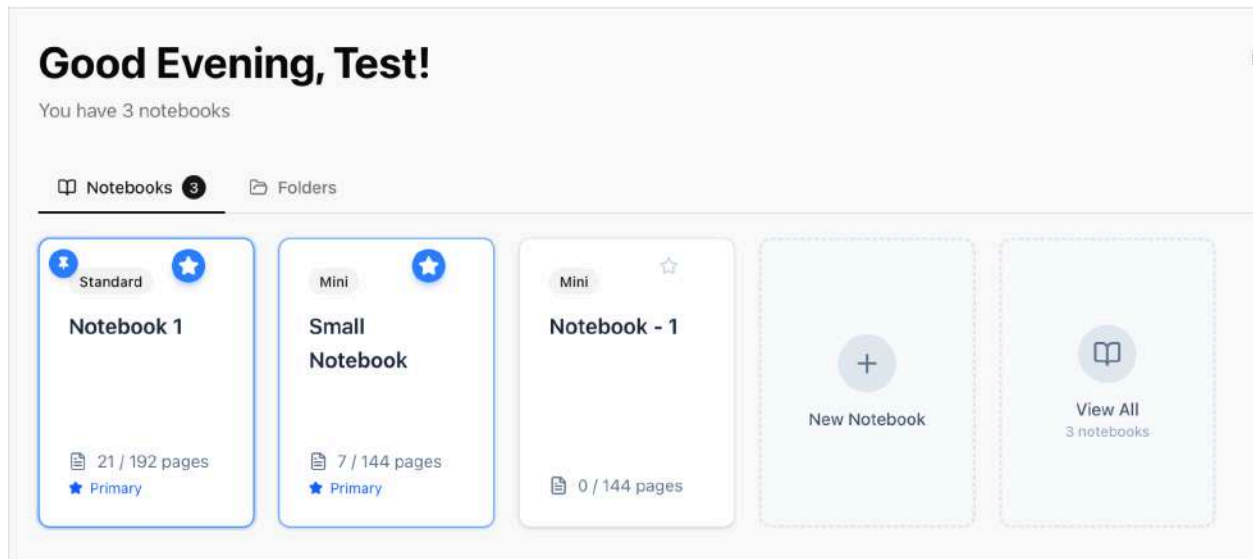

Click a notebook to open it. Click **"+ New Notebook"** (dashed border card) to create a new one ([see 3.7.2](#)). Click **"View All"** to see all notebooks ([see 3.7.1](#)).

### 3.6.3 Folders View

Switch to the Folders tab using the tab buttons at the top of the section. A count badge shows the total number of folders.

Folders are displayed as horizontal scrollable cards showing:

- Folder emoji (or default folder icon)
- Folder name
- Page count

Click a folder to view its pages ([see 3.15.3](#)). Click "+ New Folder" to create a new one ([see 3.15.1](#)). Click "View All" to see all folders ([see 3.15.2](#)).

If no folders exist, a dashed card with "No folders yet" message and a "Create your first folder" button is displayed.

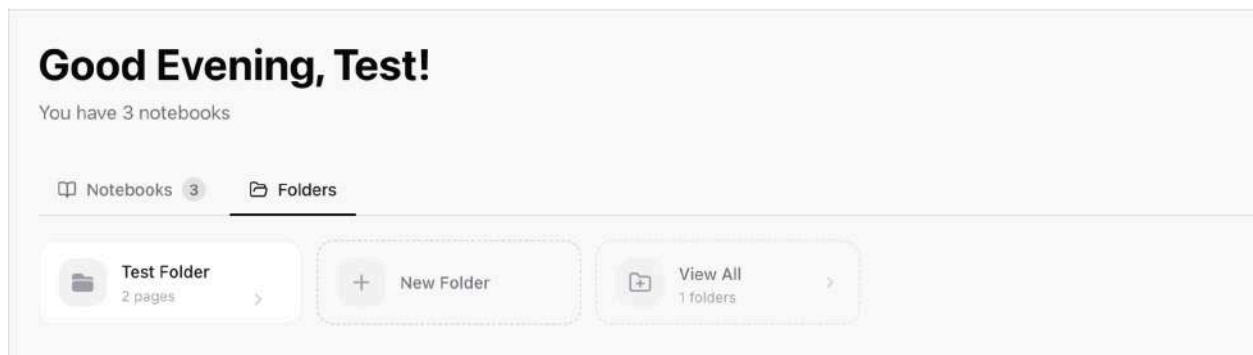

### 3.6.4 Recent Recordings

The "Recent Meetings" section shows your 5 most recent audio sessions in a responsive grid (up to 5 columns on wide screens).

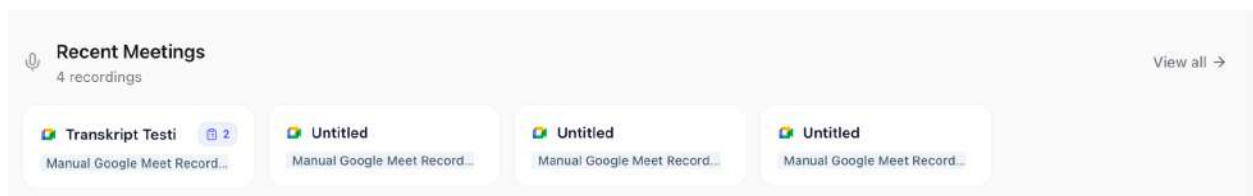

Each card displays:

- Meeting provider logo (Google Meet, Zoom, Teams) or microphone icon
- Session title
- Status badge: Uploading, Transcribing, Summarizing, Completed, or Failed
- Duration and relative time (e.g., "2 hours ago")
- Action items count (if extracted)

The section header shows: microphone icon, **"Recent Meetings"** title, total recording count, and processing count if any sessions are currently uploading/transcribing/summarizing. Click **"View all"** to see all audio sessions.

When no recordings exist, three options are displayed:

- Record on phone (use the mobile app)
- Auto-record from calendar (connect Google Calendar)
- Send a bot (send bot to a meeting)

With **"Send Bot"** and **"Connect Calendar"** action buttons.

### 3.6.5 Tasks Overview

The Tasks section shows your incomplete tasks with a progress bar indicating overall completion percentage.

The header displays: checkmark icon, **"Tasks"** title, total task count, and completed count. Click **"View all"** to go to the full Tasks page ([see 3.12](#)).

Each task card shows:

- Task emoji or source icon
- Title/description (max 2 lines)
- Due date and priority indicator
- Checkbox to mark as complete

Tasks are displayed in a responsive grid (up to 5 columns).

When all tasks are completed, an **"All caught up! No pending tasks right now."** message is displayed.

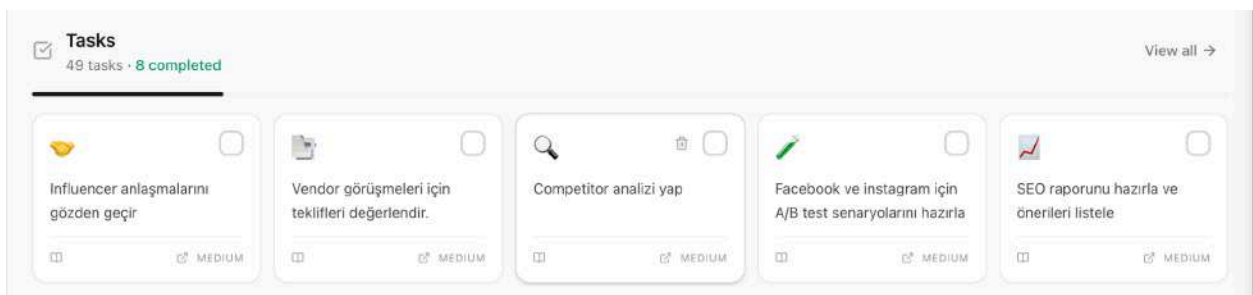

### 3.6.6 Upcoming Events

On larger screens (desktop), upcoming events appear in a collapsible right sidebar (width: 400px). Toggle it using the tab button on the right edge of the screen, which shows a calendar icon and **"X Upcoming"** text when closed. A pulsing red indicator appears on the toggle if a recording bot is currently active.

The sidebar shows:

Header area:

- XNote logo with **"Note Taker"** label
- **"How it works"** info button (expands a 4-item guide explaining the auto-record feature)
- Close button

Settings (if Google Calendar is connected):

- Auto-record toggle: Enable or disable automatic recording for all meetings. Green when ON, gray when OFF.
- Language selector: Choose the default transcription language from 14+ options (including auto-detect).
- **"Meeting Settings"** link to calendar settings page.

Event list:

- Each event card shows: event name, start time, duration, provider logo (Meet/Zoom/Teams), and recording status badge.
- Events are ordered: Active recordings first, then scheduled, then completed/cancelled.
- Each event has a toggle to enable/disable recording for that specific event.
- Click an event to view its details ([see 3.13.3](#)).

If Google Calendar is not connected, a **"Connect your calendar to see upcoming meetings"** button appears instead.

- Home
- Search
- Meetings beta
- ORGANIZE
- Events
- Tasks
- Chat
- Shares
- WORKFLOW
- Automations

### Recent Meetings

0 recordings

No recordings yet

There are 3 ways to create recordings

- Record on phone**  
Use the XNote mobile app to record meetings in person
- Auto-record from calendar**  
Connect Google Calendar to auto-record events with Meet links
- Send a bot**  
Paste a Meet, Zoom, or Teams link and a bot joins to record

[Send Bot](#) [Connect Calendar](#)

Connect your calendar to see upcoming meetings

[Connect Calendar](#)

### Tasks

5 tasks

- Design and implement a responsive... MEDIUM
- Write unit tests for the payment processing... MEDIUM
- Optimize the API response time for better... HIGH
- Integrate third-party login options such a... MEDIUM
- Complete the user authentication... HIGH

[Connect Pen](#)  
XNote Smart Pen

- Home
- Search
- Meetings beta
- ORGANIZE
- Events
- Tasks
- Chat
- Shares
- WORKFLOW
- Automations

Mini ★

**Small Notebook**

9 / 144 pages

★ Primary

[New Notebook](#)

[View All](#) 2 notebooks

### Recent Meetings

2 recordings

- Sto... 1 Manual Googl...
- Dre... 2 Manual Googl...

### Tasks

5 tasks

- Design and implement a responsive... MEDIUM
- Write unit tests for the payment processing... MEDIUM
- Optimize the API response time for better... HIGH
- Integrate third-party login options such a... MEDIUM
- Complete the user authentication... HIGH

**Auto-Record**  
Record all meetings

**Language**  
Auto-detect

**Meeting Settings**  
Auto-join, bot name & sharing

- 4 MEETINGS
- 12:07 PM Completed  
**Manual Google Meet Record...** [View](#)
  - 12:15 PM Completed  
**Manual Google Meet Record...** [View](#)
  - 11:15 AM  
**Test Meeting**
  - 05:30 PM  
**Business Meeting**

[Connect Pen](#)  
XNote Smart Pen

### 3.6.7 Note Taker Panel

On the right side of the Home screen, the Note Taker panel manages how XNote captures your meetings. Open or close it with the tab on the right edge, which also shows a quick status such as "2 Upcoming" or a red "1 Live" when a bot is recording. Click How it works to open the Guide (see [3.9.10](#)).

When your calendar is connected, the panel shows these settings (changes save automatically):

- Auto-Record: automatically sends a bot to every calendar meeting that has a video link.
- Language: the expected meeting language for transcription (default Auto-detect).
- Summary Template: the template used for AI summaries. Non-default templates are Pro and prompt an upgrade on the Free plan.
- Meeting Settings: opens the Meetings screen for auto-join, bot name, and sharing (see [3.9](#)).

Below the settings, the panel lists your upcoming and recent meetings ("N Meetings"), each showing its time, status (e.g. Completed), and bot controls. Click a meeting to open its details, or View to open the recording. If no calendar is connected, the panel shows a "Let XNote Bot take your meeting notes" prompt with a Connect Google Calendar button (see [3.13.2](#)).

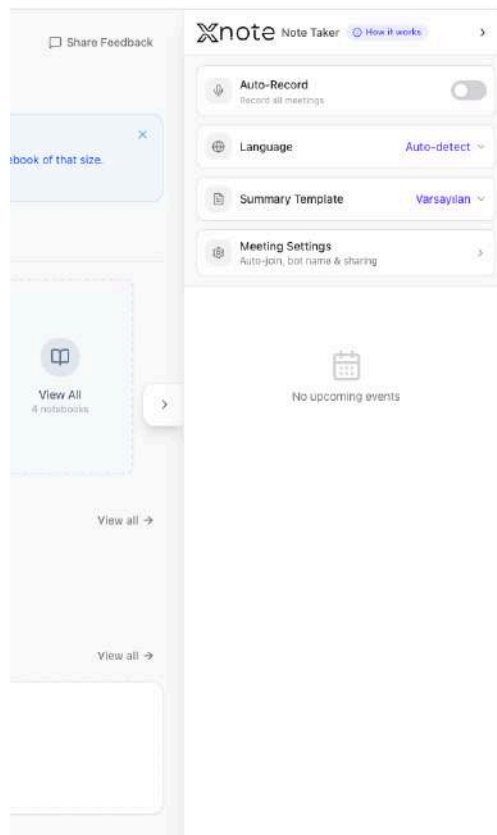

## 3.7 Notebooks & Pages

Notebooks are the core of XNote. Each notebook contains pages of your handwritten notes, synced from your XNote Pen.

### 3.7.1 View Notebooks

All your notebooks are displayed on the Notebooks page in a responsive grid (up to 5 cards per row). Each notebook card shows:

- Notebook type badge (Mini / Standard / Large)
- Title
- Page count (e.g., "**23 / 192 pages**")
- Primary star icon (filled blue if primary)
- Pin indicator (blue border and ring if pinned)

Pinned and primary notebooks appear first, followed by most active.

Click a notebook to open it.

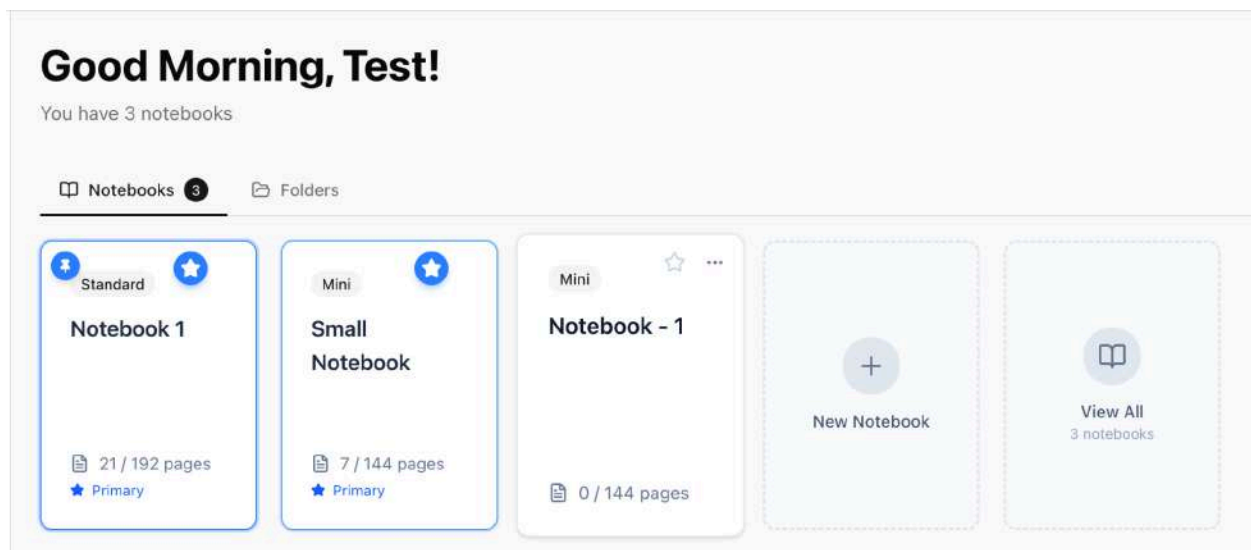

### 3.7.2 Create a Notebook

1. Click "+ New Notebook" on the Home page or Notebooks page.

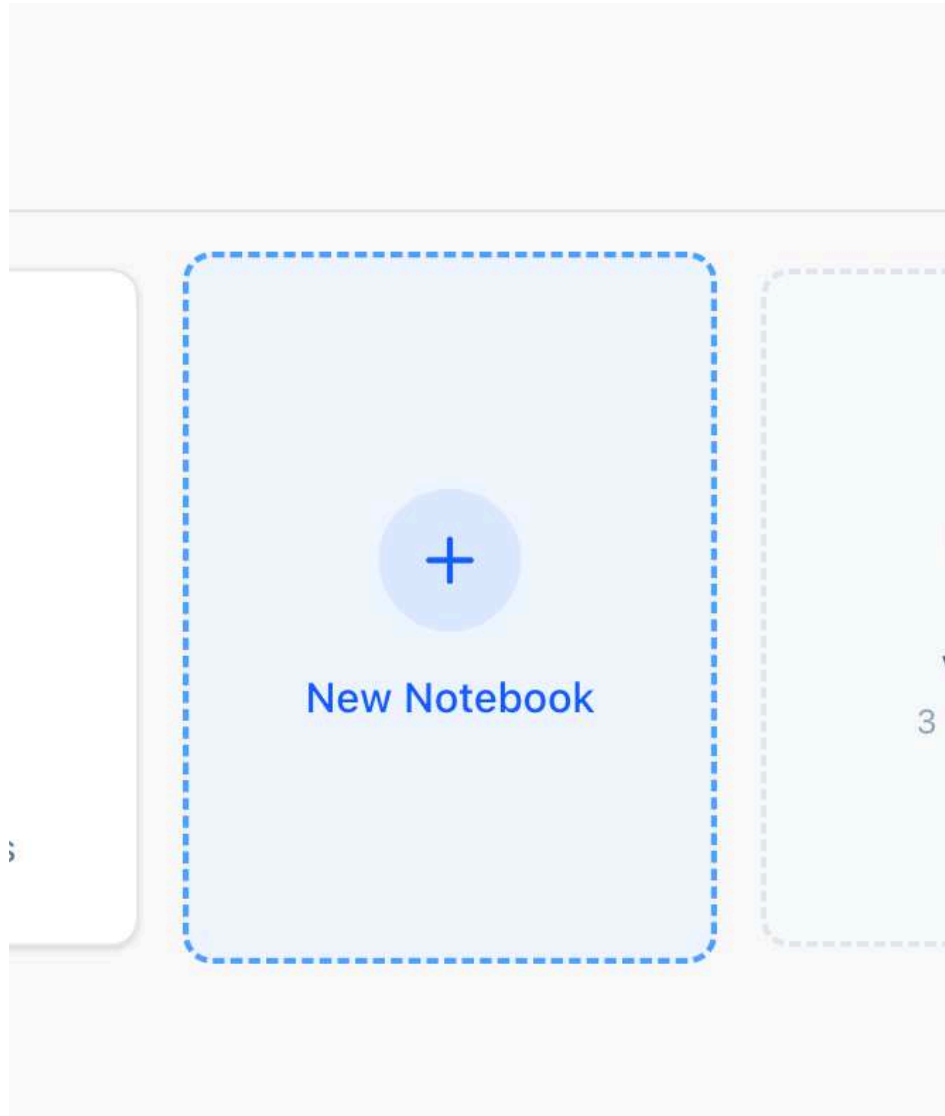

2. A dialog appears. Select the notebook size:

- Mini (144 pages)
- Standard (192 pages)
- Large (192 pages)

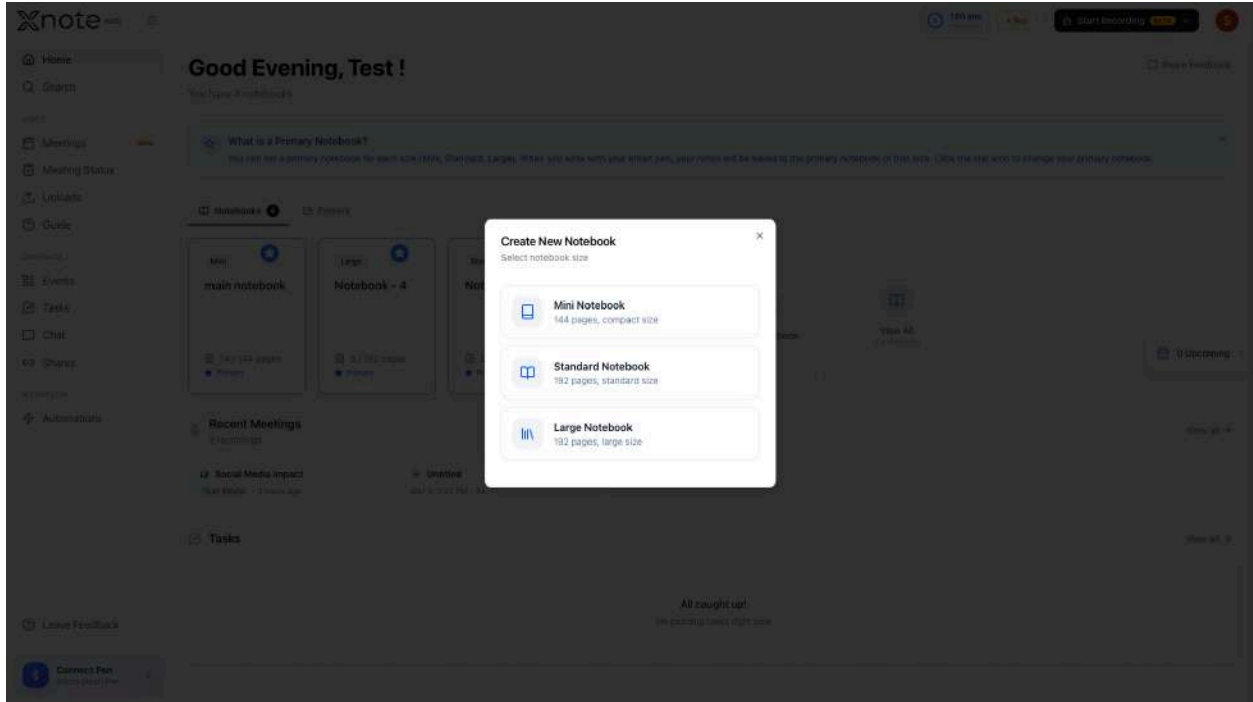

3. The notebook is created automatically. If it is the first of its size, it becomes your primary notebook. If multiple notebooks of the same size exist without a primary, a selection modal will ask you to choose one.

### 3.7.3 Set Primary Notebook

Click the star icon on any notebook card to set it as primary. The star turns filled blue with a **"Primary"** label. You can also open the notebook's settings dialog and click **"Set as Primary"**.

In Settings -> Primary Notebooks, use the dropdown selectors for each size.

[See 3.5](#) for full details on what primary notebooks are and why they matter.

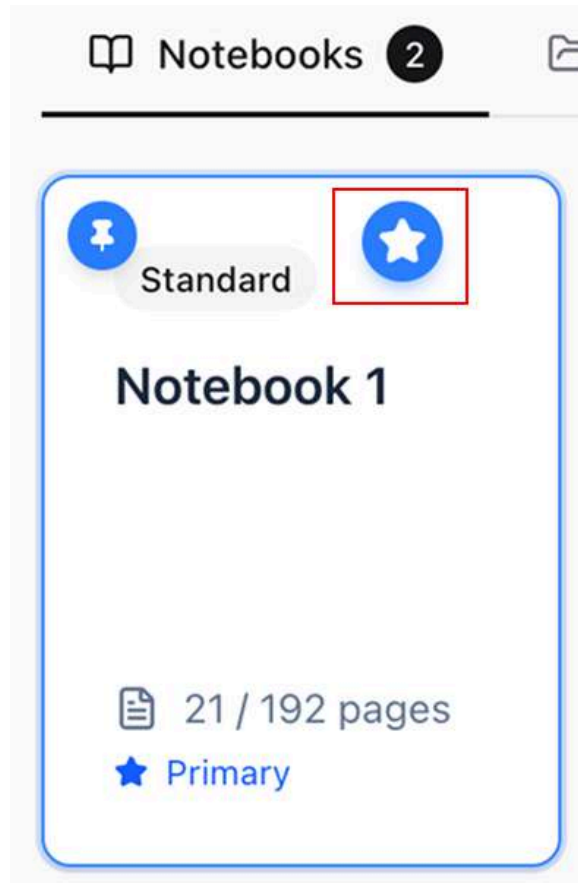

### 3.7.4 Pin a Notebook

1. Open the notebook settings dialog (click the three-dot menu on a notebook card).
2. Click **"Pin Notebook"**.

The pinned notebook moves to the top of the grid with a blue pin badge and ring. Only one notebook can be pinned at a time.

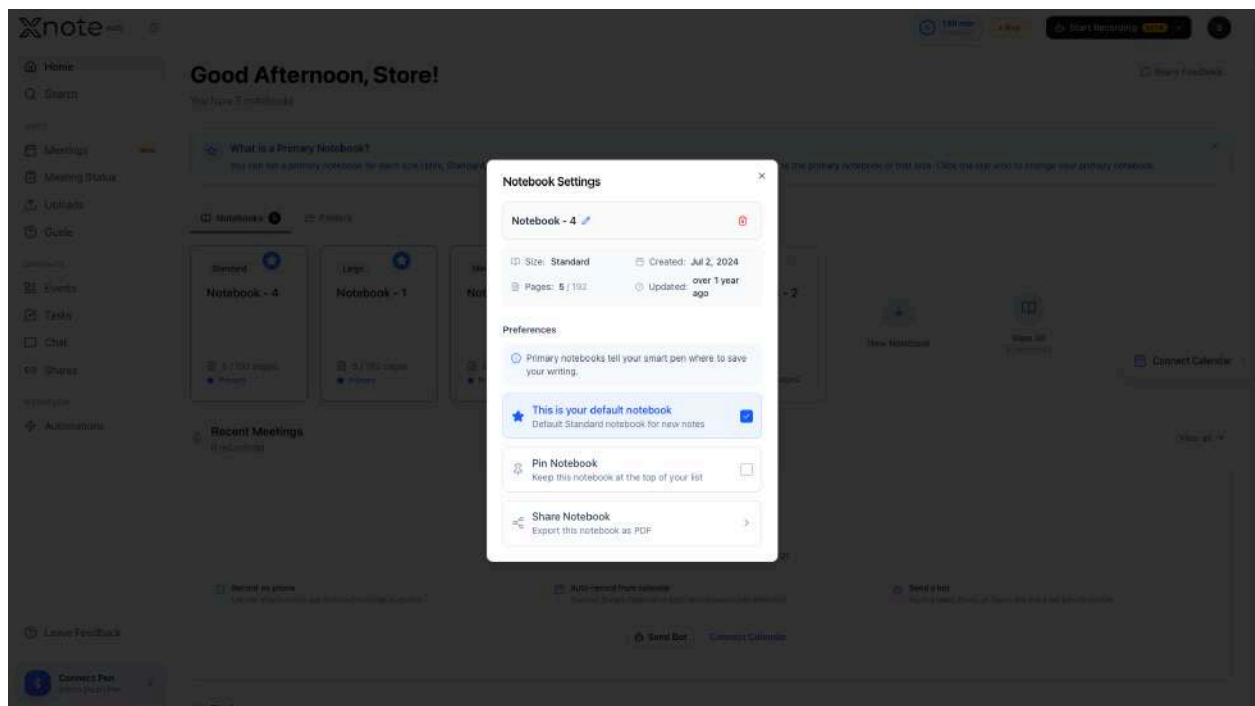
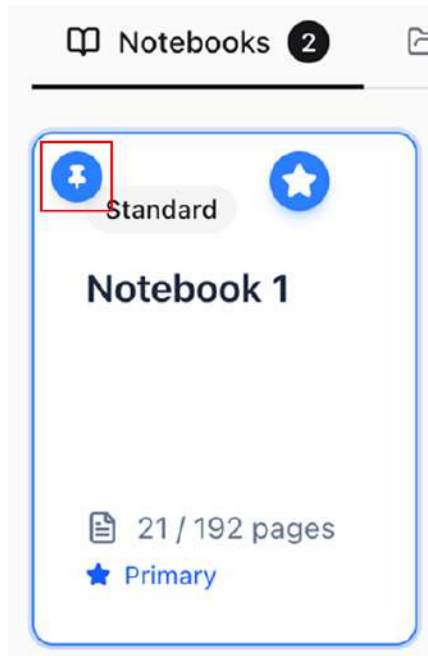

## 3.7.5 Browse Pages

Click a notebook to view its pages in a responsive grid (up to 8 columns on wide screens). Each page shows a thumbnail with rendered handwriting strokes and a page number label below.

To export multiple pages, click **"Export Pages"** to enter selection mode. A selection banner appears with **"Select All"** / **"Deselect All"** toggle. Check the pages you want, then click **"Export"** in the floating action bar at the bottom.

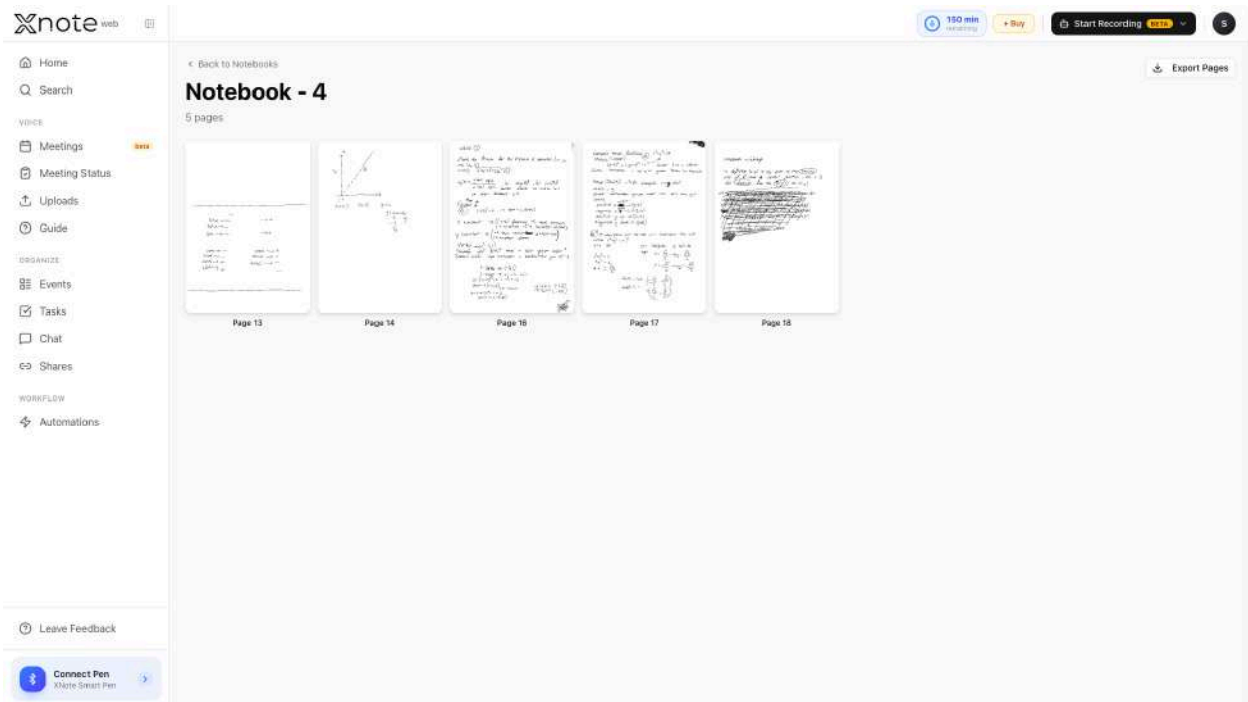

### 3.7.6 View Page Details (Canvas & Text)

Click a page to open the detail view in a fullscreen canvas layout.

#### Canvas:

The main area displays your handwriting at full size with the notebook background (if enabled). Navigate between pages with the arrow buttons in the toolbar or keyboard arrow keys (left/right).

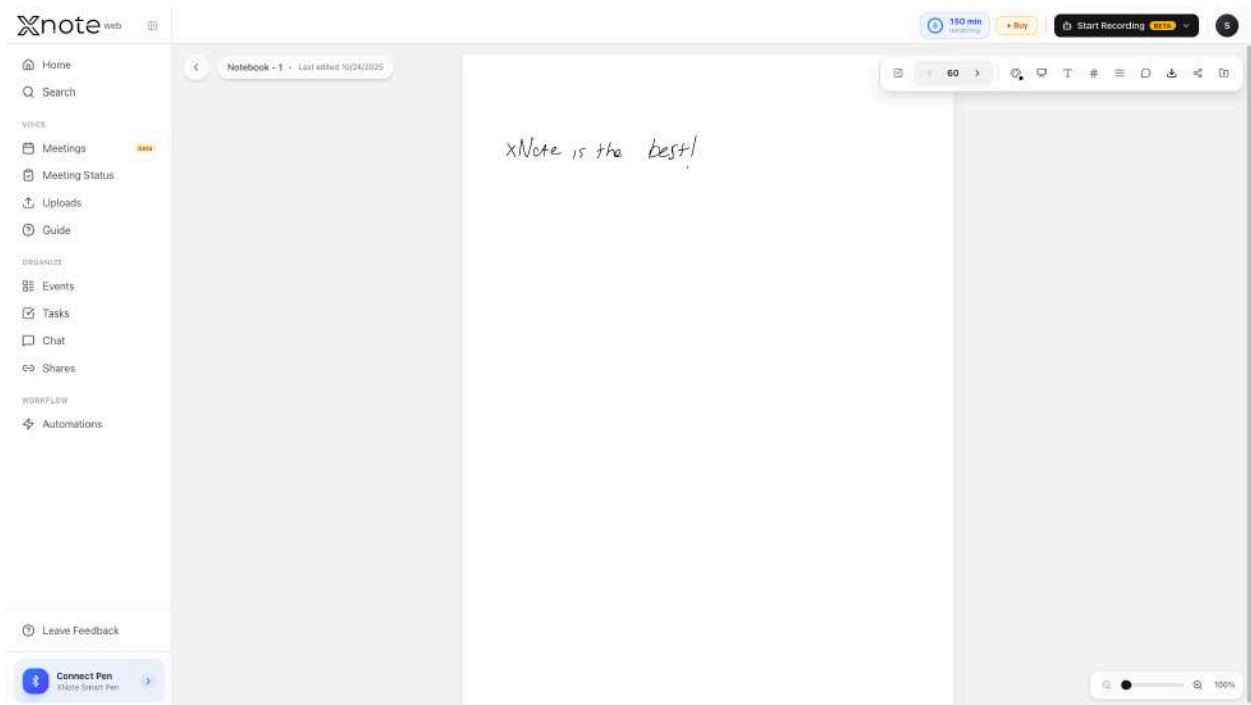

## Text Panel:

Click the "Aa" icon in the toolbar to slide open the text panel from the right (520px wide). It shows the OCR-extracted digital text of the page. The panel includes:

- Font size controls (+/- buttons, range 12-24px)
- Tab selector for "Text" and "Diagram" (if diagrams exist on the page)
- Word and character count at the bottom
- "Edited by user" indicator if the text has been manually modified

Press Escape to close the text panel.

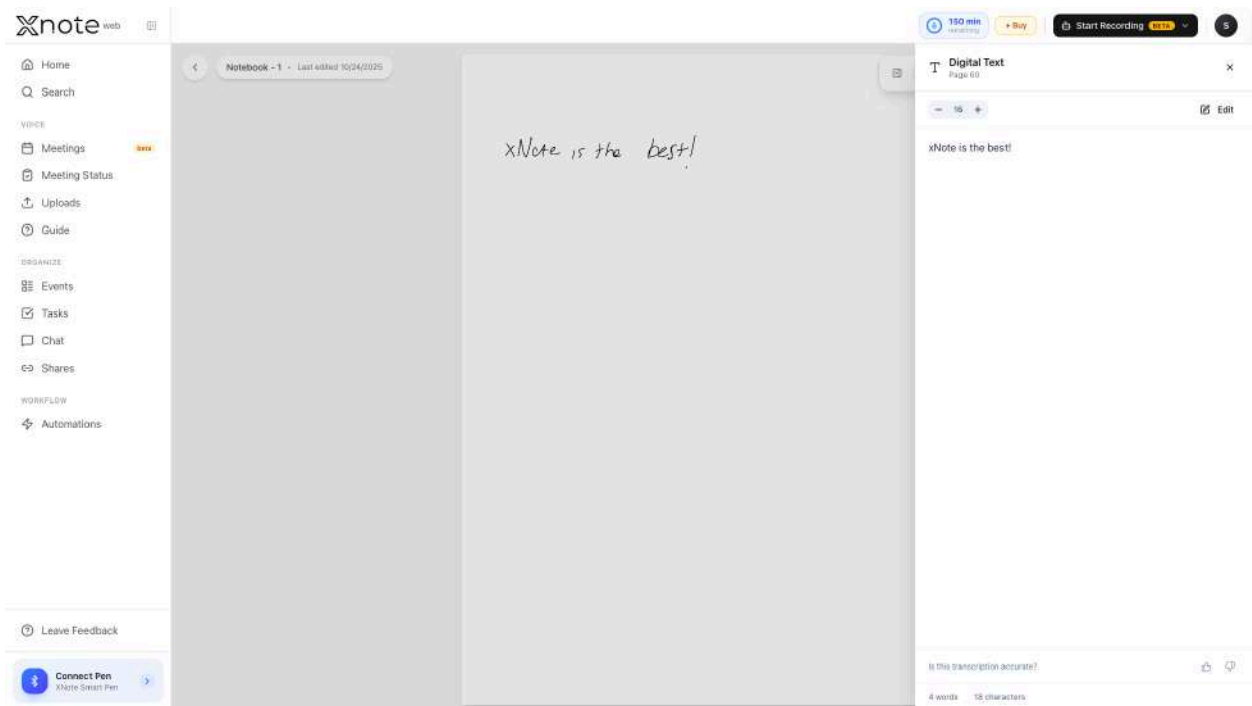

## Toolbar:

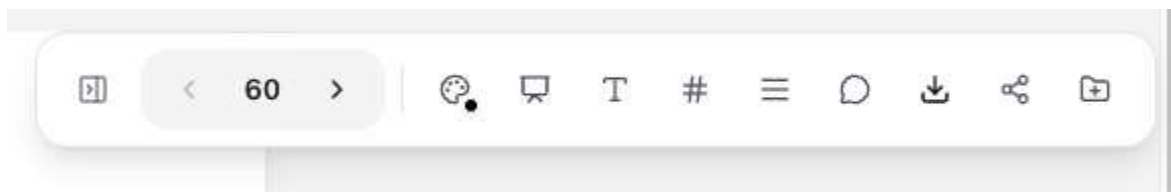

The top-right toolbar (white, blurred background, rounded) provides quick access to:

- Page Navigation (Arrows + number) : Navigate between pages (previous/next, current page display).
- Digital Text (Aa icon) : Toggle the OCR text panel on/off.

- Tags (Label icon) : Open the Page Tag Manager ([see 3.15.6](#)).

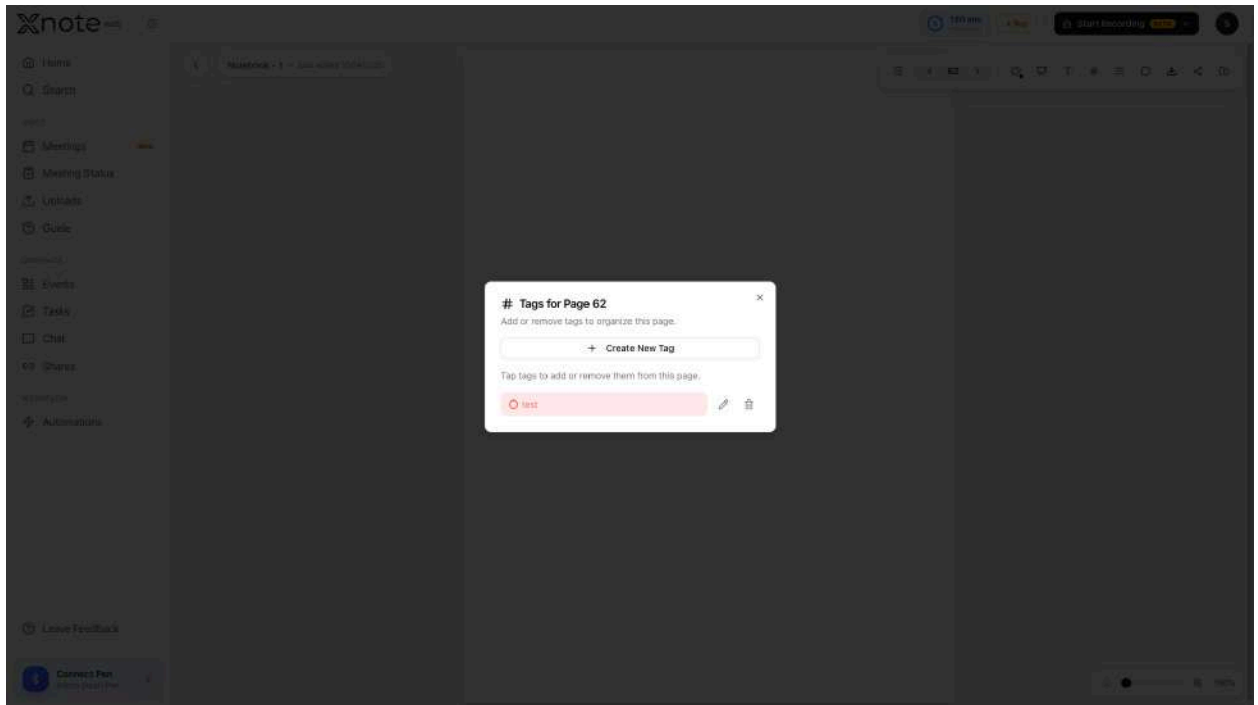

- Background (Lines icon) : Toggle notebook background lines on/off.

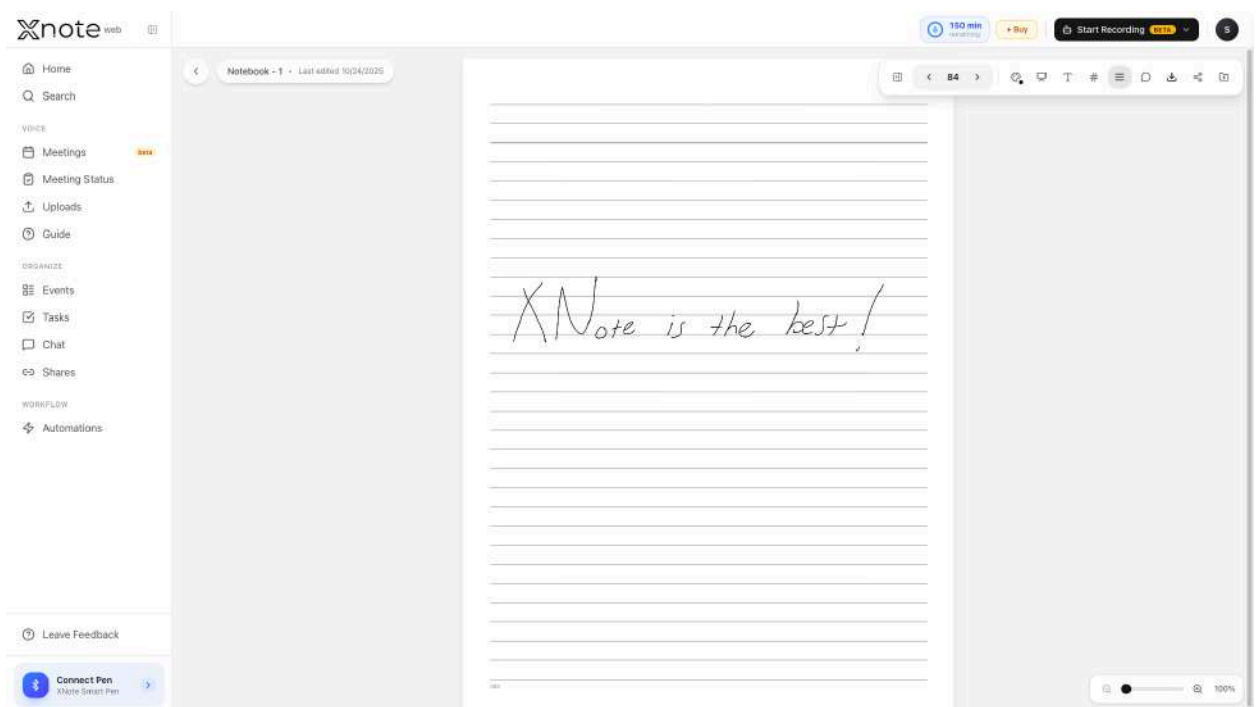

- Chat (Message icon) : Open AI Chat with this page as context ([see 3.10](#)).
- Export (Download icon) : Quick export the current page.

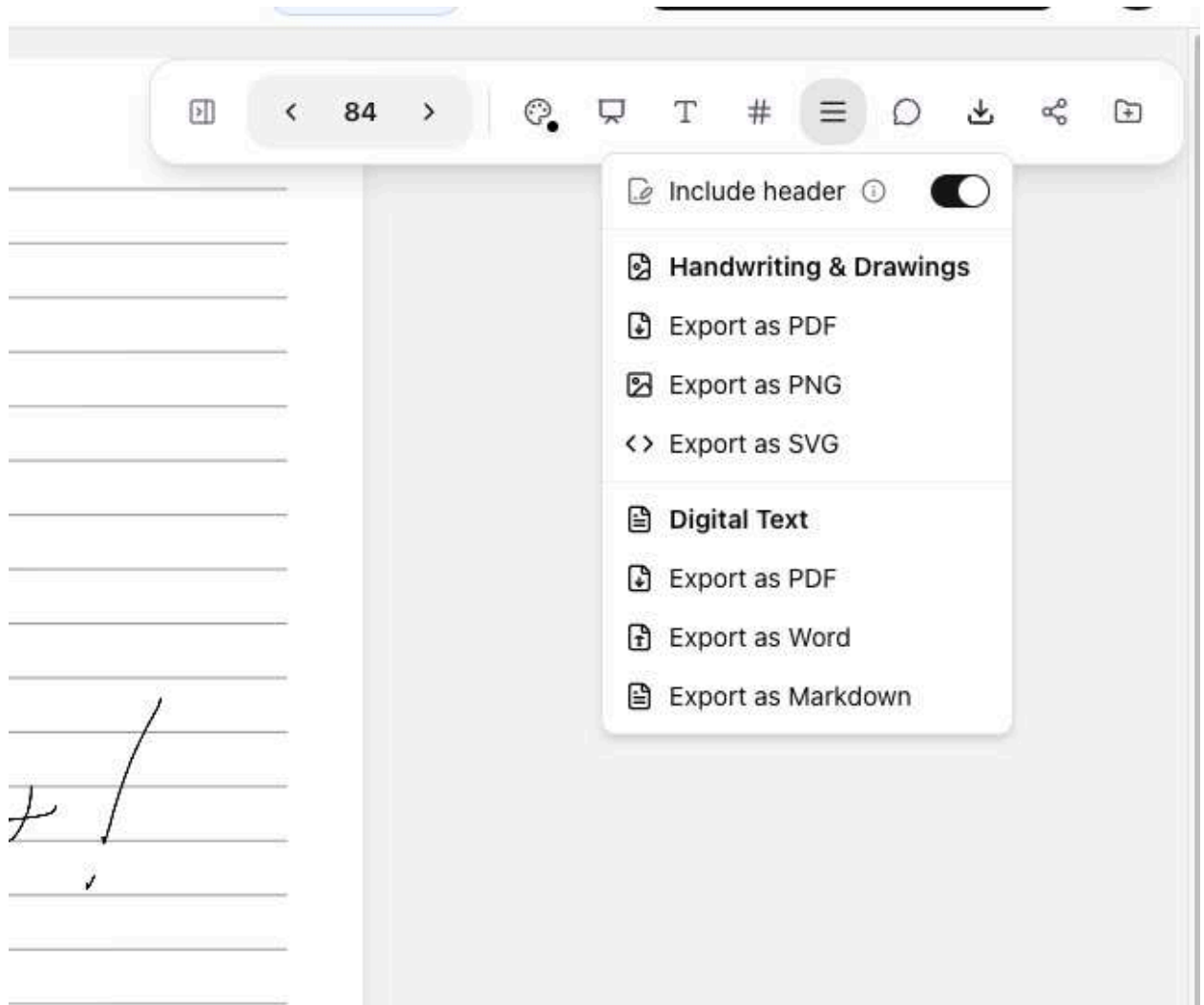

- Share (Share icon) : Create a shareable link for this page [\(see 3.16.1\)](#).

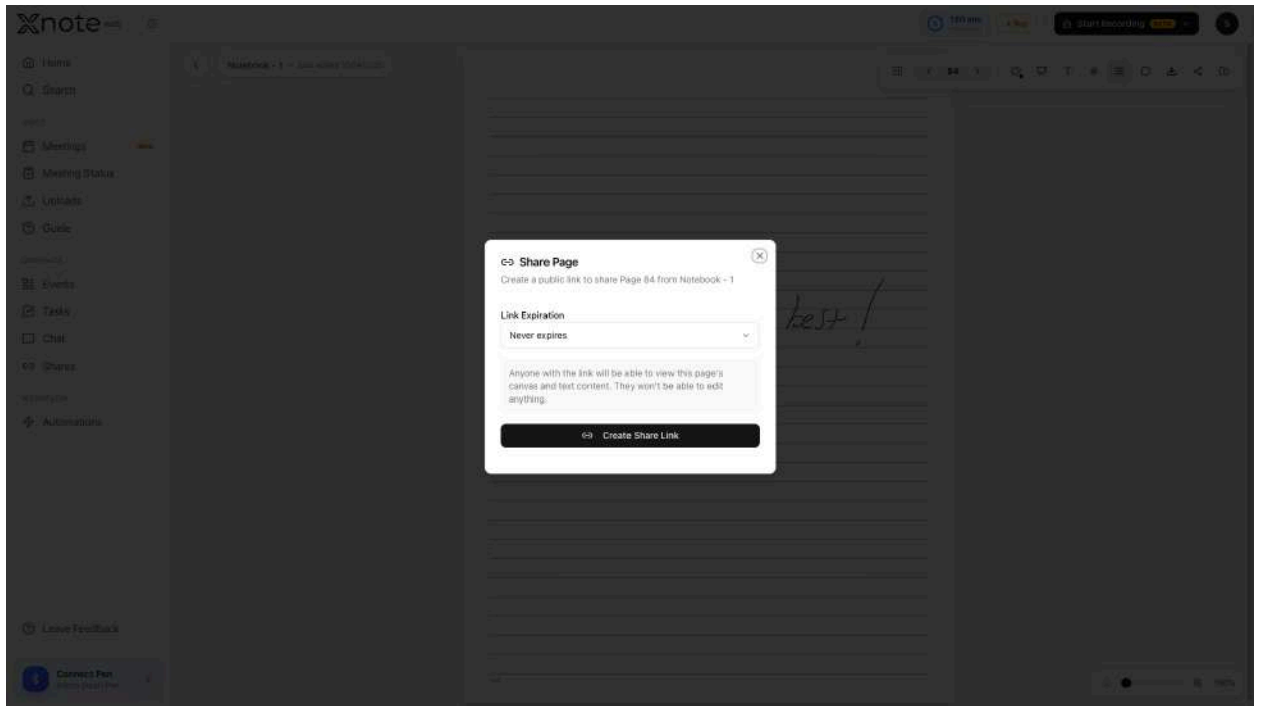

- Folder (Folder+ icon) : Add this page to a folder [\(see 3.15.4\)](#).

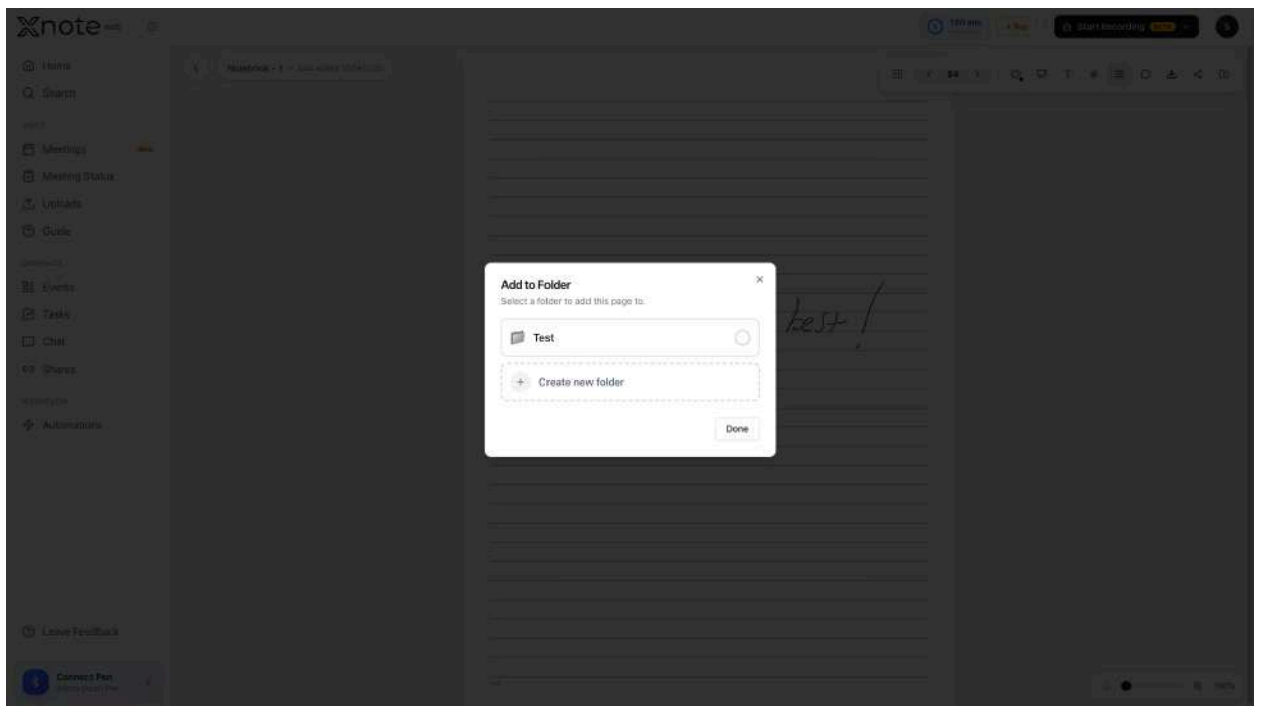

- Pen Color (Palette icon) : Change the display color of your handwriting. Opens your device's native color picker; the dot on the icon shows the current color.



- Presentation Mode : Click the screen icon in the toolbar to open the current page in a distraction-free, full-screen view for presenting. Move between pages with the on-screen arrows or the left/right arrow keys, and press Esc to exit. A floating control bar provides the essentials while presenting: Pen Color, Digital Text, Toggle lines, and Export. The current page number is shown so your audience can follow along.



Top-left shows a back button and the notebook title with last edited time.

Canvas drawing: Drawing on the canvas is available only via the connected XNote Pen.

### 3.7.7 Edit Page Content

Edit Text:

1. Open the text panel (click **"Aa"**).
2. Click **"Edit"** in the panel header.
3. Modify the text in the textarea. Word and character counts update in real-time.
4. Click **"Save"** to apply changes, or **"Cancel"** to discard. An unsaved changes indicator (red dot) appears while editing.

If the page contains diagrams, a **"Diagram"** tab appears next to the **"Text"** tab in edit mode, allowing you to edit diagram labels without changing the diagram structure.

Canvas: Drawing on the canvas is available only via the connected XNote Pen mouse/touch drawing is not supported on web.

Note: Editing the text does not change your handwriting on the canvas it only modifies the digital text representation used for search, export, and AI features.

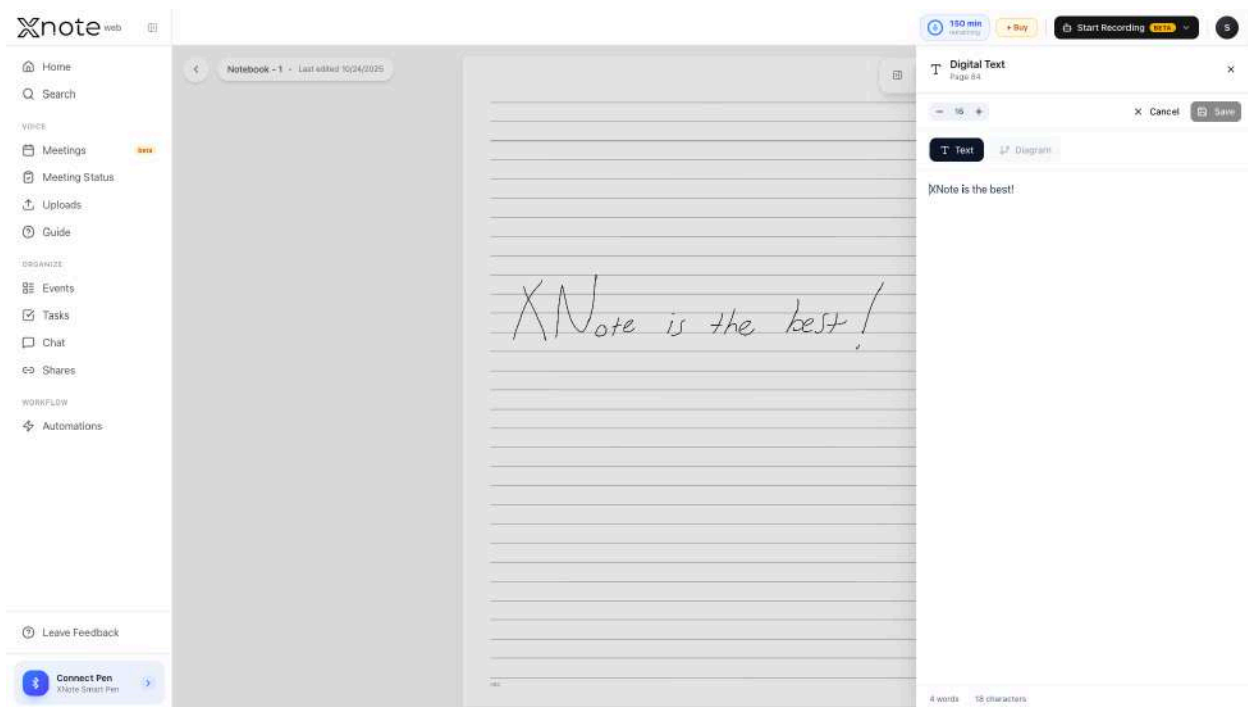

### 3.7.8 Delete a Notebook / Page

Delete a Notebook:

1. Open the notebook settings dialog (click the three-dot menu on a notebook card).
2. Click the trash icon in the top-right of the dialog.
3. Confirm in the dialog: **"Are you sure you want to delete '[notebook title]'? This action cannot be undone."**

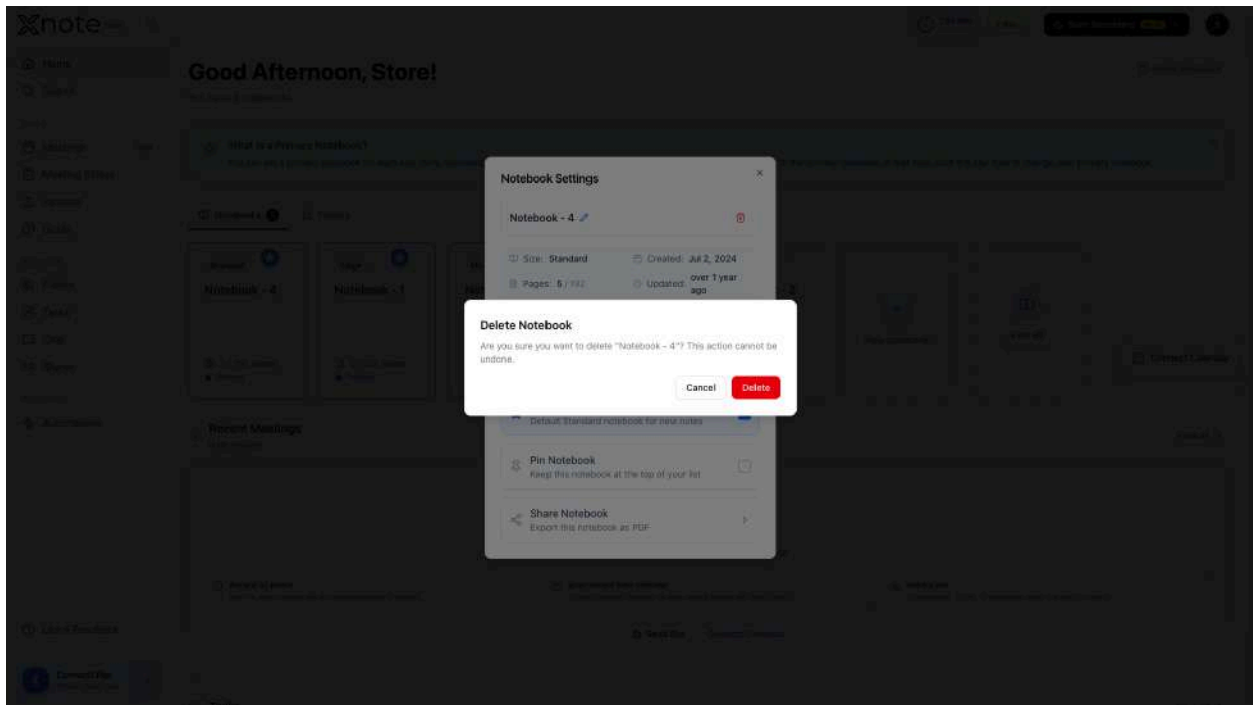

If you delete a primary notebook, XNote will automatically assign another notebook of the same size as primary.

Delete a Page: Individual page deletion is not available on web. Pages are removed when their notebook is deleted.

## 3.8 Pen Settings & Factory Reset

Manage your XNote Smart Pen's configuration. Pen Settings are only available when the pen is connected via Bluetooth.

How to access:

- From the sidebar: Click the **"Pen Connected"** button to expand the pen dropdown, then access settings.
- From Settings: Pen Settings section appears in the Settings page when the pen is connected.

### 3.8.1 Pen Settings

The Pen Settings section (visible only when pen is connected) shows:

- Device Info : Pen name and firmware version (read-only).
- Auto Power-Off : Set the idle time before pen turns off. Options range from **"Never"** to **"10 hours"** (in 1-hour increments). Default: 6 hours.
- Pen Sounds : Toggle the pen's beep sounds on or off. Default: on.

Settings are synced across all your devices. An info banner notes: **"Settings are synced across all your devices. Changes are saved automatically."**

Click **"Apply Settings to Pen"** to push the current settings to the pen. Settings are also automatically applied when the pen first connects (after a 2-second delay).

Note: Unlike the mobile app, Mirror Writing and Color Picker settings are not available on web. These are mobile-only features ([see 2.7.1](#)).

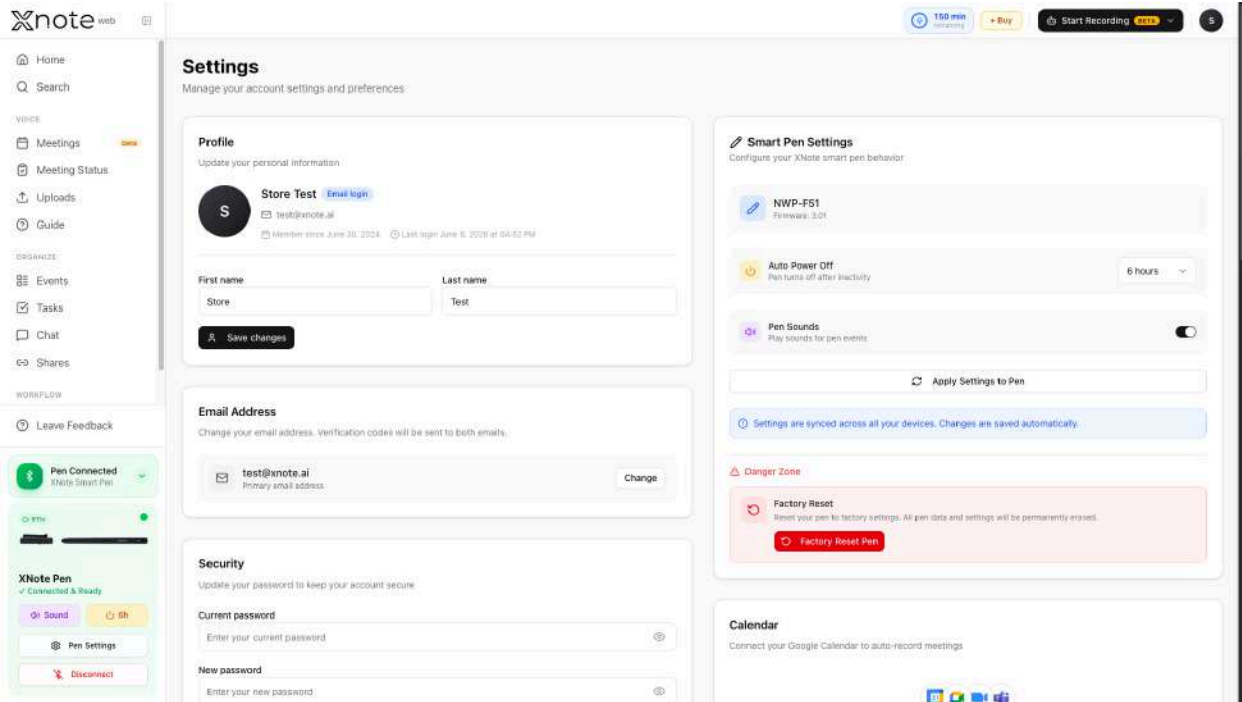

### 3.8.2 Factory Reset

Factory Reset completely resets your XNote Smart Pen to its original factory settings. This erases all pen data and settings permanently. Your account, notebooks, and synced notes are not affected.

The Factory Reset button is located in the **"Danger Zone"** section at the bottom of the Pen Settings area (red styling).

Step 1 : Click **"Factory Reset Pen"** in the Danger Zone section.

Step 2 : First Confirmation

A warning dialog will appear:

**"This will completely reset your pen to factory settings. All pen data and settings will be lost. This action cannot be undone."**

Click **"Continue"** to proceed.

Step 3 : Second Confirmation

A second dialog will ask:

**"Are you absolutely sure? This will erase all pen data permanently. The pen will disconnect and reset to factory settings. This action cannot be undone."**

Click **"Reset Now"** to confirm.

The button shows **"Resetting..."** with a spinner during the process. Once complete, the pen will disconnect automatically. You can re-pair it via Bluetooth ([see 3.4](#)).

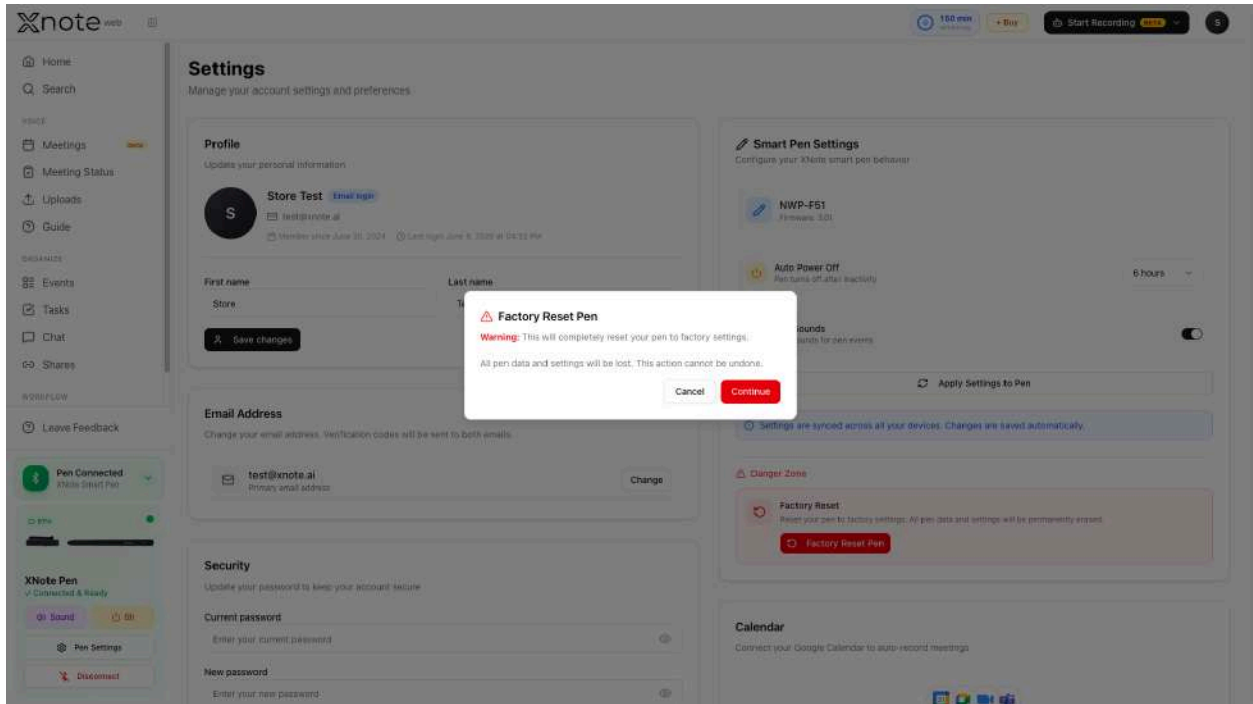

## 3.9 Meetings & Audio Sessions

XNote Web supports audio recording through the Meeting Bot and calendar integrations. Manual microphone recording is not available on web use the mobile app for that.

The Meetings page shows all your audio sessions in a responsive grid (1-3 columns). You can search sessions by title. Each card shows the provider logo, title, status badge, duration, and task count. Color-coded audio minute cards at the top show your remaining quota (green = 30+ min, blue = 6-30 min, yellow = 1-5 min, red = depleted).

In the sidebar, audio features live under the Voice group: Meetings (this section), Meeting Status (3.9.8), Uploads (3.9.9), and Guide (3.9.10).

### 3.9.1 Meeting Bot (Send Bot to Meeting)

Click "**Send Bot**" on the left header

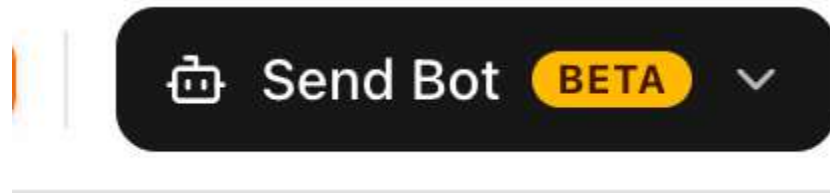

1. Enter the meeting link. XNote auto-detects the platform (Google Meet, Zoom, or Microsoft Teams) and shows a provider badge with a checkmark when the URL is valid.

2. Optionally set:

- Bot name (default: "**XNote Note Taker**"). This name will appear in the meeting participant list.
- Transcription language: Auto Detect (default) or select from 14 languages.
- When to join: "**Join Immediately**" (default) or "**Schedule for Later**" with a date/time picker and duration (15, 30, 45, or 60 minutes).

3. Click "**Send Bot**".

Your remaining audio minutes are shown in the dialog with color-coded status. If your quota is depleted, the Send Bot button is disabled.

If a bot is currently active in another meeting, an amber warning explains that you need to stop it first. If a bot is scheduled for another meeting, a blue info message notes it will be cancelled and will rejoin automatically after the new bot finishes.

On success, a green checkmark with "**Bot is joining!**" (or "**Bot scheduled!**") is displayed.

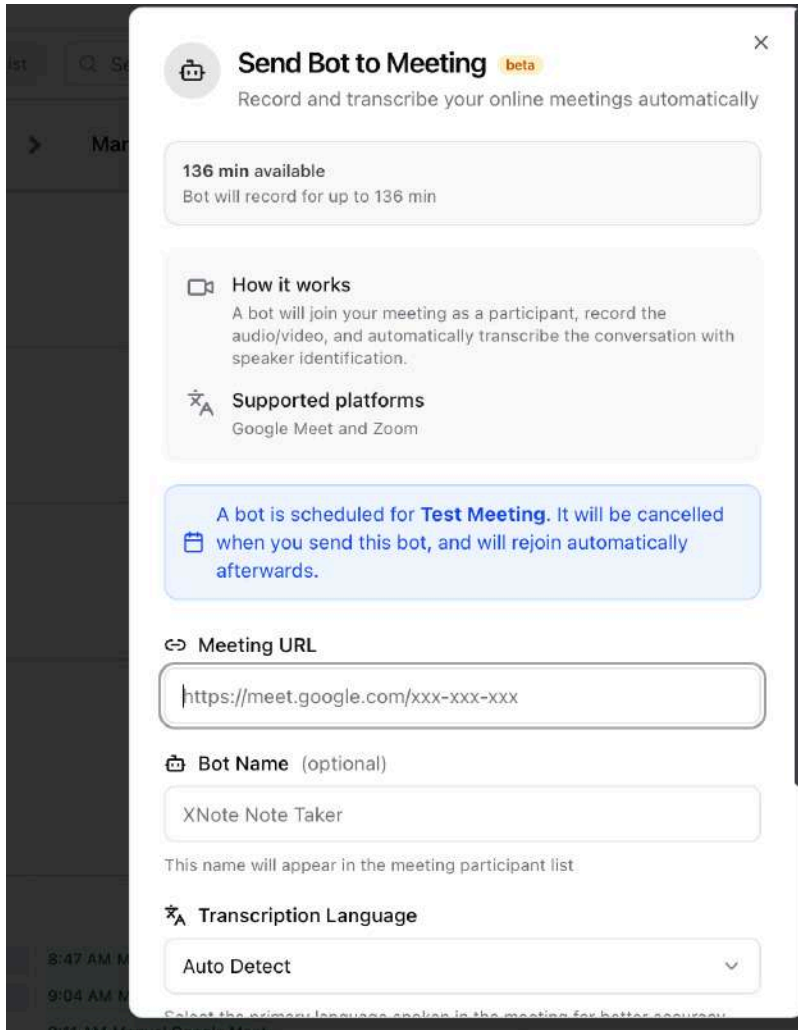

### 3.9.2 Audio Session Detail

Click any audio session to open the detail page. The detail page has parts:

Overview Part:

- Shows the AI-generated summary with markdown rendering ([see 3.9.3](#))
- Audio player with waveform, progress bar, play/pause, and current time / total time display
- Speaker selector dropdown
- Action items section with count badge ([see 3.9.5](#))

Transcript Tab:

- Full transcript grouped by speaker with colored dots
- Each segment shows speaker name (clickable to rename [see 3.9.4](#)), timestamp (clickable to seek audio), and spoken text with word-level highlighting during playback
- Click any word or timestamp to jump to that point in the audio

## Notes Tab:

- Shows notebook pages linked to this recording ([see 3.9.6](#))
- Page thumbnails with status badges (Auto, Included, New)
- Hover over a page to reveal the remove button
- **"Link Pages"** button to add more pages

## Session Header:

- Session title (click to edit inline)
- Meeting provider logo and duration
- Options menu (three dots): Delete, Download, etc.

## Share:

Click the share link button to share the recording ([see 3.9.7](#)).

The screenshot displays the Xnote web interface during a recording session. The top navigation bar includes the Xnote logo, a search bar, and a sidebar with options like Home, Meetings, and Uploads. The main content area is titled "Social Media Impact" and features a video player at the top. Below the video, there is an "AI Summary" section with three sub-sections: "Key takeaways", "Filming Challenges", and "Social Media Addiction". Each section contains a list of bullet points summarizing the recording's content. To the right of the AI summary is a "Transcript" section showing a verbatim transcript of the audio. The interface also includes a "Share" button in the top right corner and a "Connect Pen" button in the bottom left corner.

### 3.9.3 Summary & Templates

After a recording is complete, select a summary template to generate the transcript and AI summary.

1. Click **"Generate"** on the recording.
2. Choose a template from the dropdown (Default, Meeting Notes, Action Items, etc.).
3. The summary appears in the main area, rendered as formatted markdown text.

To edit the summary: Click **"Edit"** to switch to a textarea. Modify the text and click **"Save"**, or **"Cancel"** to discard.

To regenerate: Click the regenerate button to re-trigger summarization with the current or a different template.

### 3.9.4 Speaker Identification & Renaming

Speakers are automatically identified as Speaker 1, Speaker 2, etc., with unique colored dots.

To rename a speaker:

1. Click the speaker name in the transcript.
2. A rename modal appears with the current name and an input field.
3. Enter the new name and click **"Save"**.

The name updates across the entire transcript instantly.

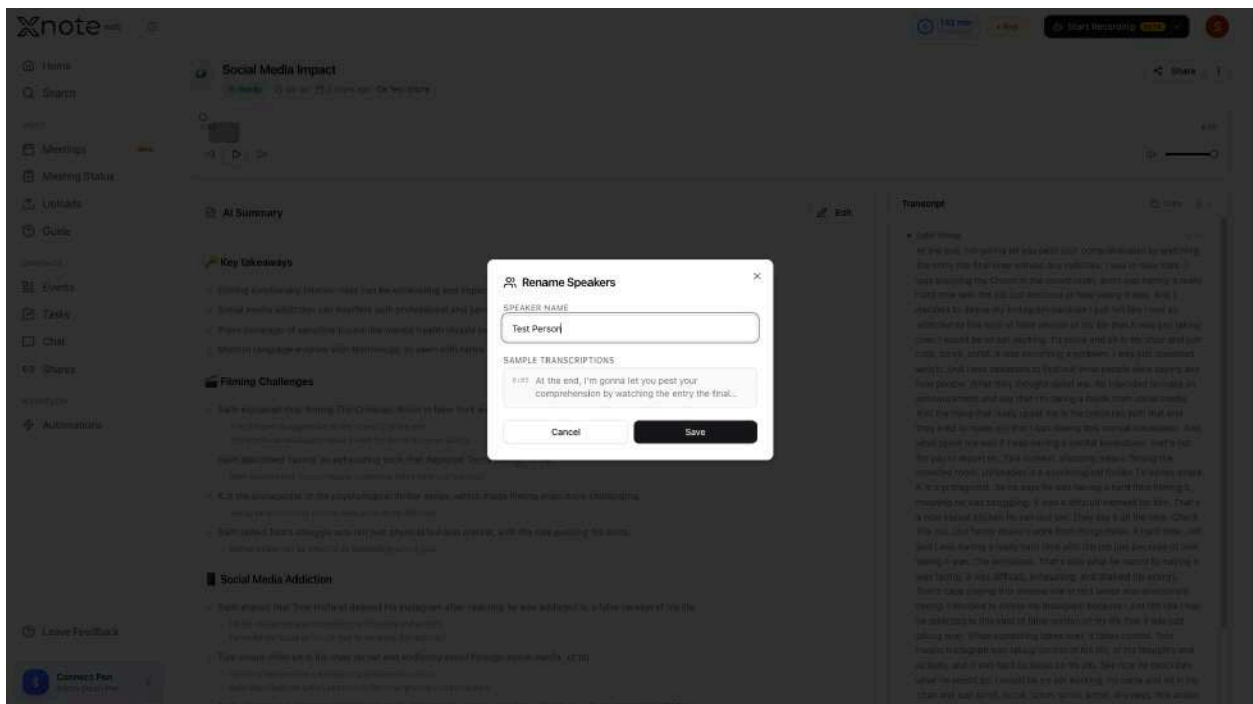

### 3.9.5 Action Items

If action items are extracted, a count badge appears in the Overview tab.

Each action item shows:

- Task description with checkbox
- Assigned person (if identified)
- Due date (if mentioned)
- Priority level (high / medium / low)
- **"Add to Tasks"** button

Click **"Add to Tasks"** on an action item to save it to your Tasks [\(see 3.12\)](#). When all action items are added, a completion indicator appears.

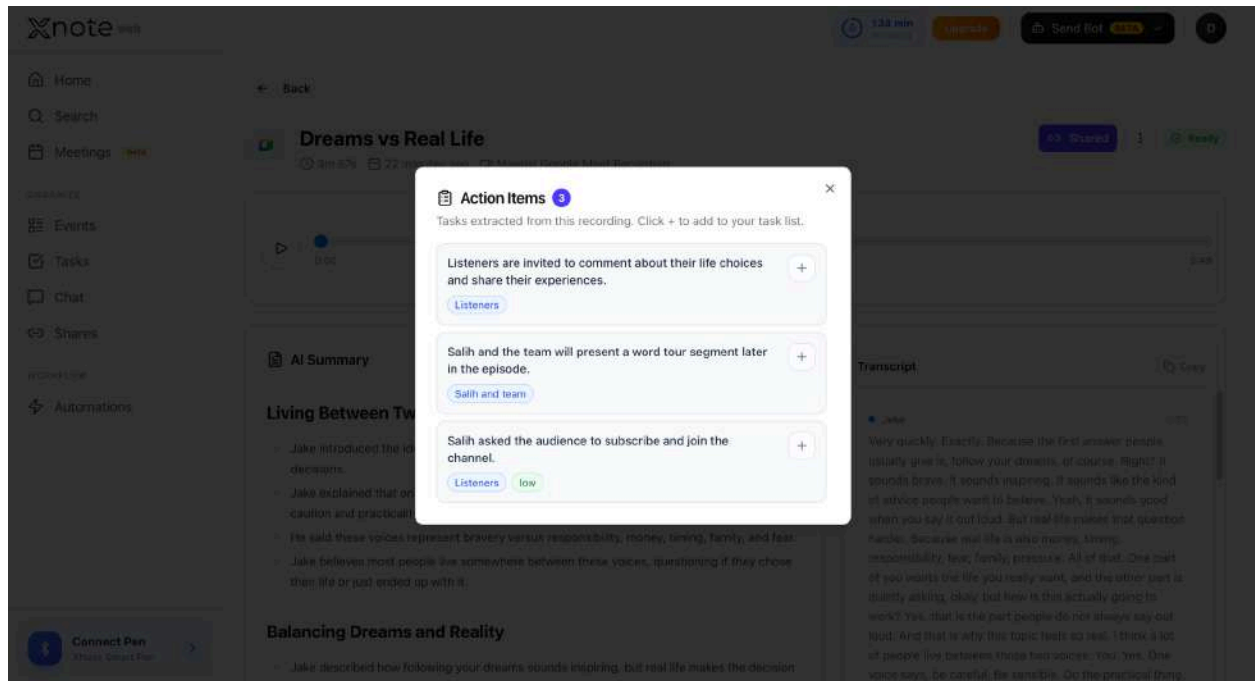

### 3.9.6 Link Pages to Recording

Link notebook pages to a recording for context.

1. In the Notes tab, click **"Link Pages"**.
2. A modal opens with your notebooks listed on the left (collapsible). Click a notebook to show its pages as a thumbnail grid (2-4 columns).
3. Click pages to select them. Selected pages show a blue border and checkmark.
4. Status badges appear on each page:
  - Auto : Automatically linked based on writing during the recording
  - Included : Included in the previous AI summary context
  - New : Newly selected, not yet included in the summary
5. Click **"Link X Pages"** to confirm.

A page counter shows how many pages are selected (e.g., **"3 pages selected"**).

If pages are added or changed after the summary was generated, a banner prompts you to regenerate the summary with the updated pages.

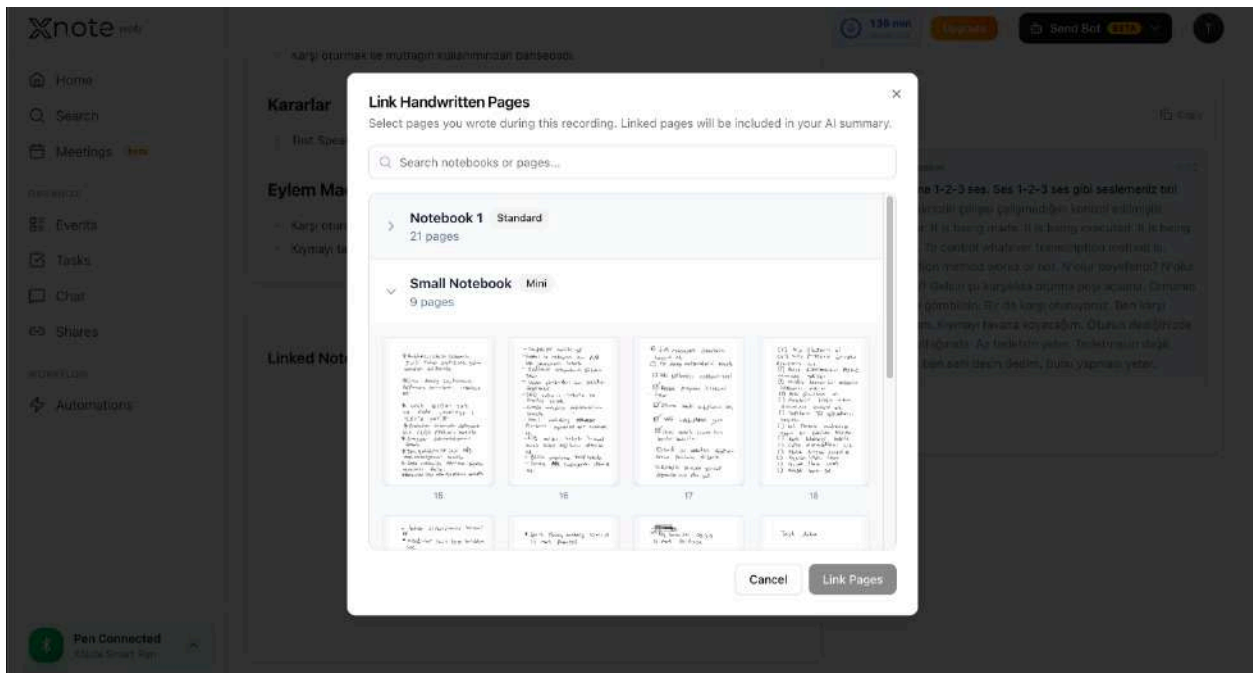

### 3.9.7 Share & Audio Minutes

Share a Recording:

1. Open an audio session and click the share link button.
2. Select an expiration:
  - 7 days (default)
  - 30 days
  - 1 year
  - Never
3. Optionally enable email notification to share with attendees.
4. Click **"Create Share"**.

The shared link includes the AI-generated summary. The audio file remains private.

Once a link is created, you can:

- Copy the link to clipboard
- Open the link in a new tab
- Revoke the link to disable access

A **"Shared Links"** dropdown in the bottom-right shows all active shares for this recording, with copy, open, and revoke options for each.

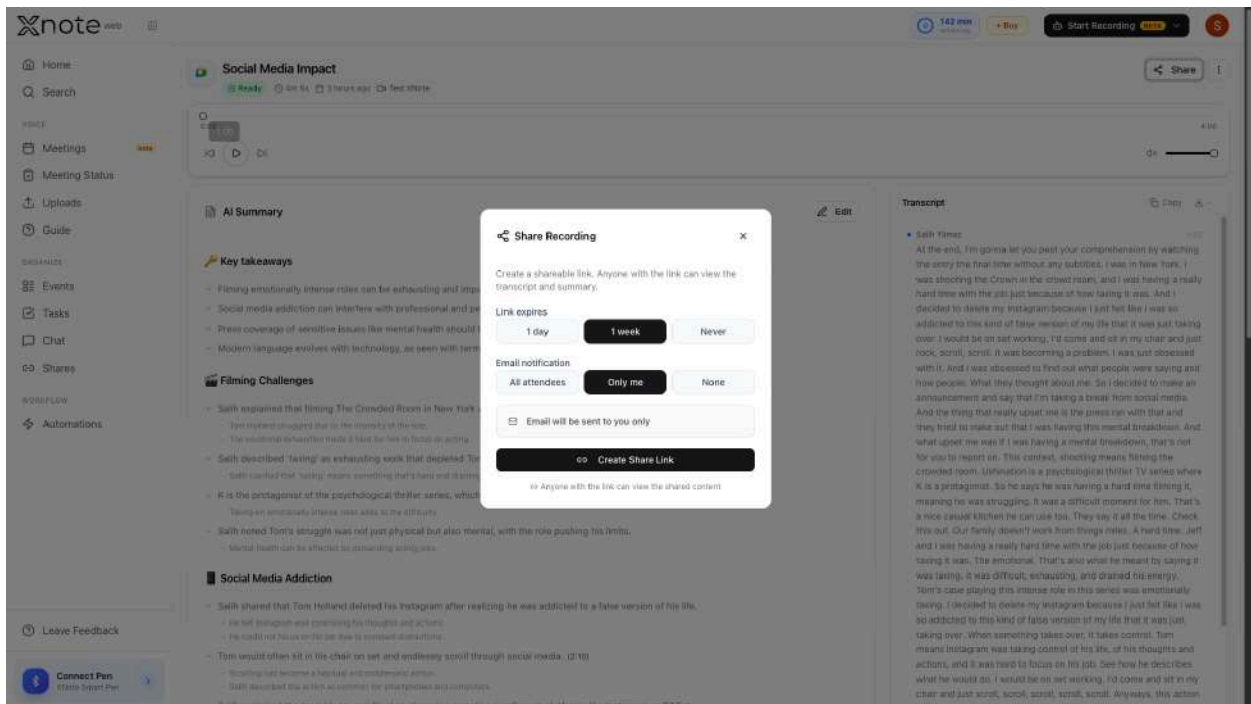

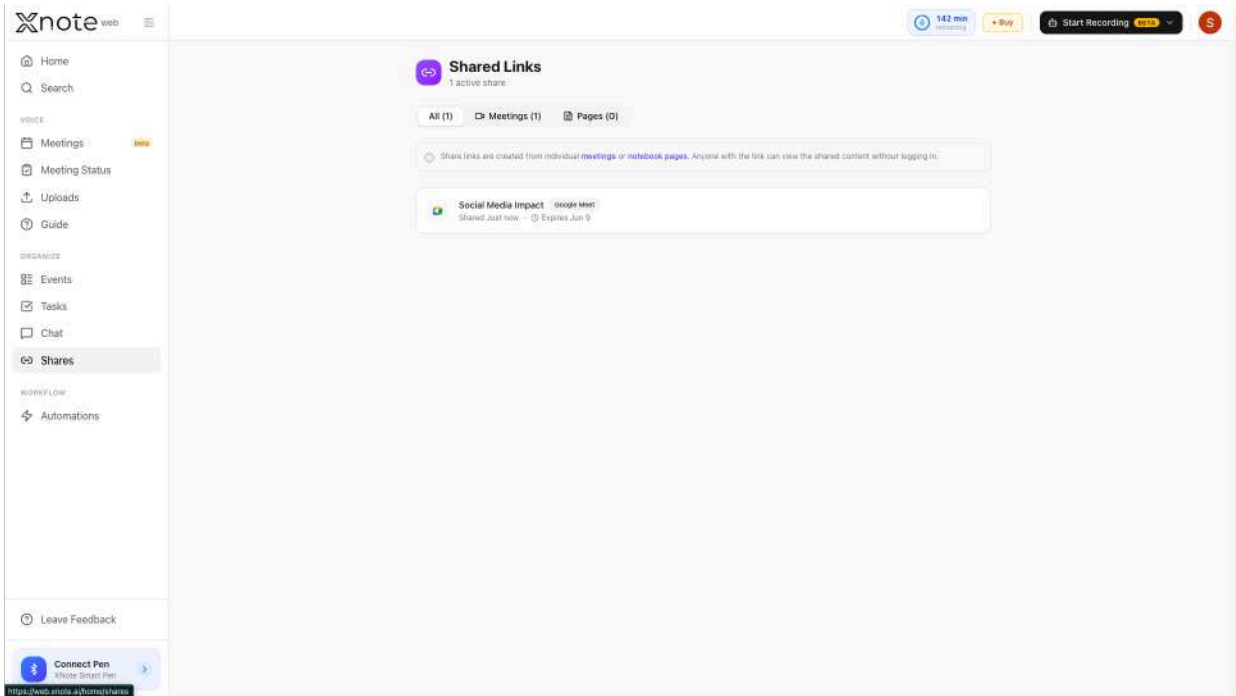

### Audio Minutes & Limits:

Audio minutes are shared across bot recordings and calendar recordings.

Each card shows the exact remaining minutes and quick action buttons: **"View Plans"** or **"Add More Minutes"**.

To get more minutes, upgrade your plan or purchase add-on minutes from Settings -> Subscription.



### 3.9.8 Meeting Status

The Meeting Status screen (Voice → Meeting Status) tracks the live and recent state of your recording bots in one place. A red dot appears on the sidebar item whenever a bot is active.

Ongoing. Bots that are currently working appear at the top with a live status such as Recording or Joining, a Live badge, and a control to stop the bot.

Sessions list. Below, all recording sessions are grouped by week. Filter with the toggles; Ongoing, Completed, Needs Transcription, Failed or click All. Search by title or keyword, switch between list and grid view, and sort weeks by date or titles within each week.

Retry. If a bot failed for a retryable reason, a Retry button lets you send it again.

When there are no sessions, the screen shows "No recording sessions yet."

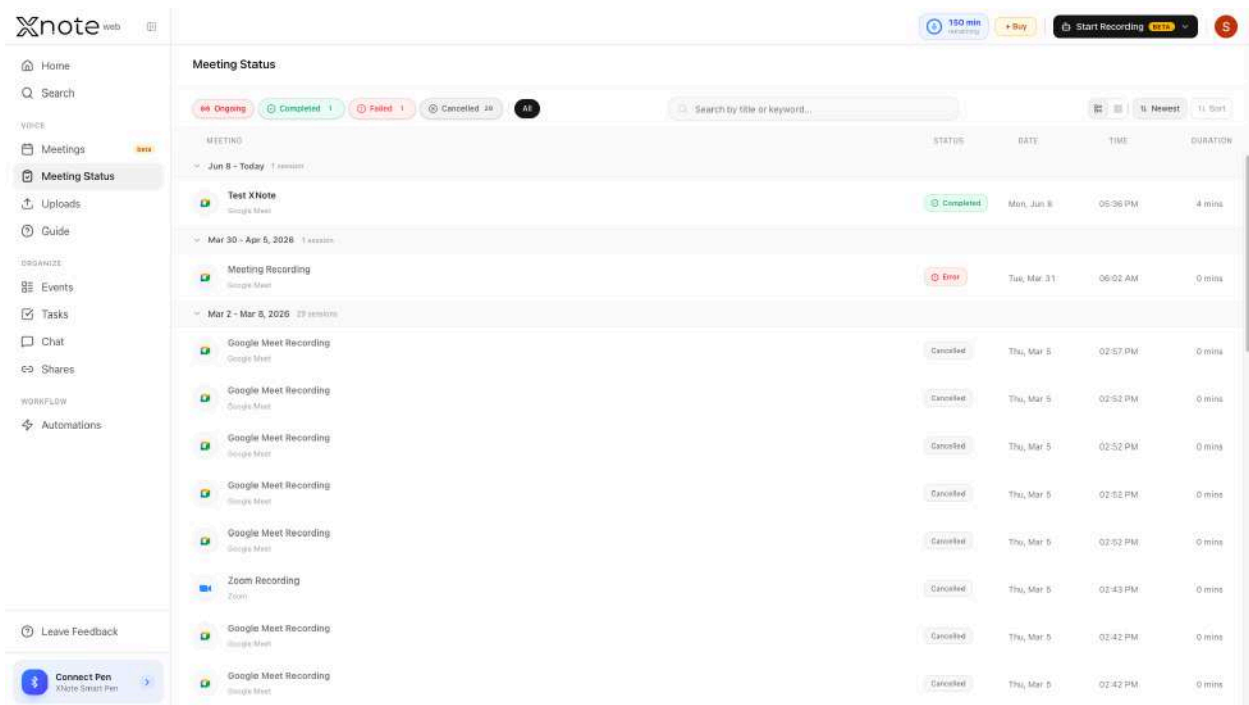

### 3.9.9 Uploads

The Uploads screen (Voice → Uploads) lists voice recordings captured and uploaded from the XNote mobile app .For example, in-person meetings or lectures recorded on your phone. Each upload is automatically transcribed and summarized.

Sessions are grouped by week, each showing a processing status Uploading..., Transcribing..., Summarizing..., Needs Transcription, Needs Summary, Completed, or Failed. Filter with the Completed / Needs Transcription / Failed toggles (or All), search by title or keyword, switch between list and grid view, and sort by date.

Click any upload to open its detail view, where the transcript, AI summary, speakers, and action items work exactly like a meeting recording (see [3.9.2–3.9.5](#)).

When the list is empty, the screen shows "No uploads yet . Use the XNote mobile app to record and upload voice recordings."

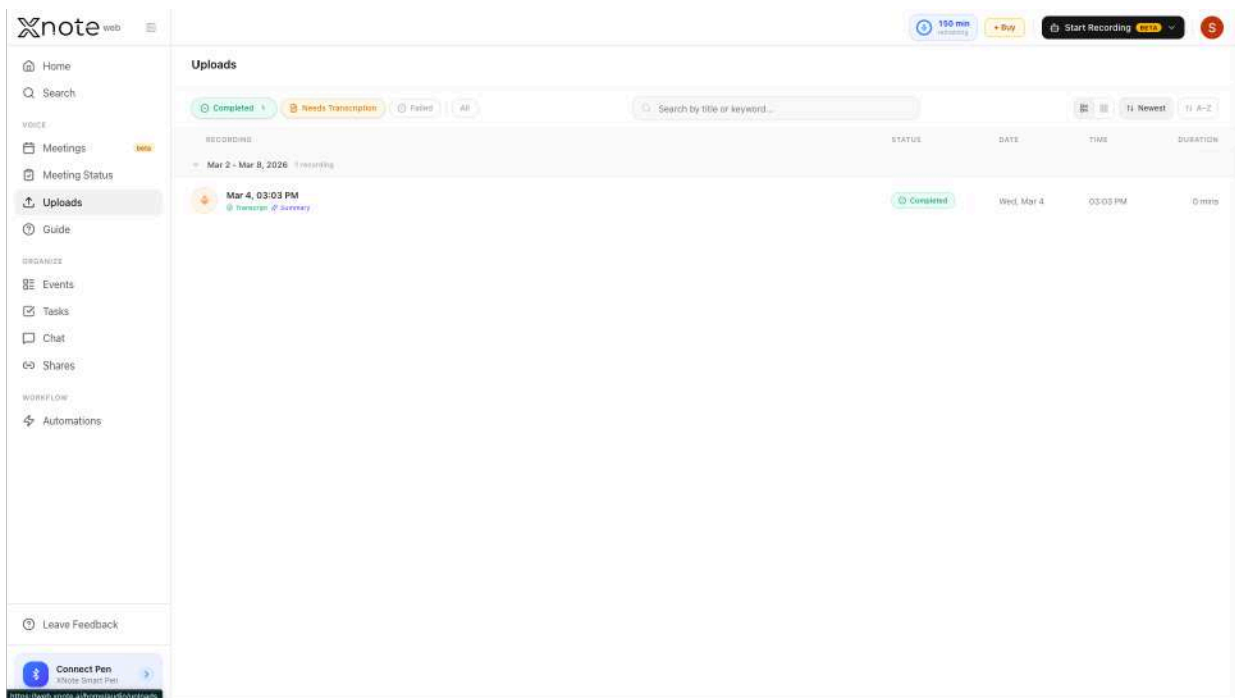

### **3.9.10 Guide**

The Guide screen (Voice → Guide, also reachable via How it works in the Note Taker panel) explains how XNote's meeting bot works end to end. It covers:

- Auto-Record Meetings: how to enable automatic recording and the required Calendar settings.
- Supported platforms: Google Meet, Zoom, and Microsoft Teams.
- During the meeting: how the bot joins, records all attendees, and the controls available at any point.
- After the meeting: viewing the recording, transcript, summary, and Shared Links.

Use this screen as a quick reference when setting up automated meeting notes for the first time.

## 3.10 AI Chat

XNote Web includes a full-page AI assistant accessible from the left sidebar navigation.

### 3.10.1 Start a Conversation

Click **"Chat"** in the sidebar to open the chat page. The empty state shows a greeting with four quick-access feature cards in a 2x2 grid:

- Summarize (violet) : Create a summary from your notes
- Flashcards (amber) : Generate study flashcards
- Translate (emerald) : Translate to another language
- Create Chart (blue) : Visualize your data

Below the cards, suggestion pills appear with common prompts.

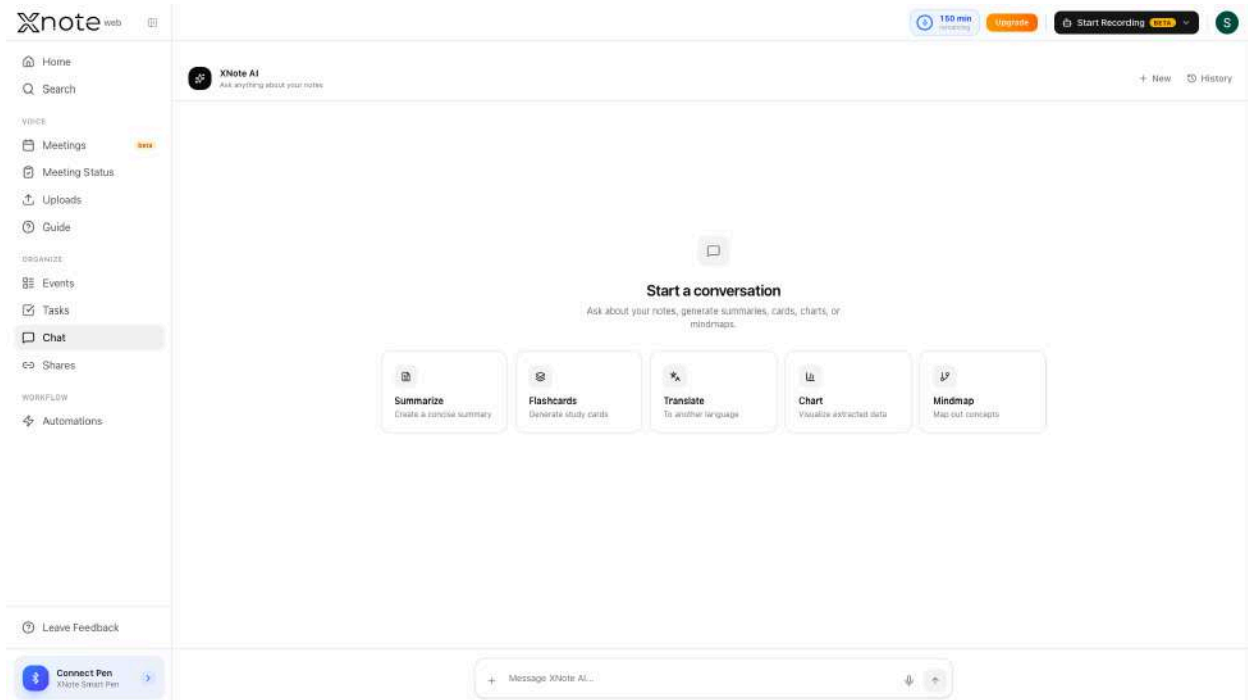

Type your message in the input field at the bottom. Press Enter to send (Shift+Enter for newline). The send button (arrow icon) appears when text is entered. AI responses stream in real-time with markdown rendering.

To start a new conversation, click the **"New"** button (plus icon) in the header.

Note: Voice input is not available on web. Use text input only.

- Home
- Search
- VOICE
- Meetings
- Meeting Status
- Uploads
- Guide
- ORGANIZE
- Events
- Tasks
- Chat
- Shares
- WORKFLOW
- Automations

XNote AI Ask anything about your notes + New History

Hi, what is XNote

XNote is an app developed by XNote Inc. that bridges physical note-taking with digital workflows. It works with a special pen or stylus to turn handwritten notes into searchable digital knowledge, enabling seamless syncing and integration with other apps and tools.

Leave Feedback

Connect Pen XNote Smart Pen

SUGGESTIONS

How does the special pen work? What platforms is XNote available on? Can I use XNote without the pen?

+ Message XNote AI...

### 3.10.2 Mention Pages in Chat

Click the "+" button (left of the input field) to open the page mention dropdown.

1. Your notebooks are listed with color badges and page counts. Primary notebooks are marked with a **"Primary"** label.

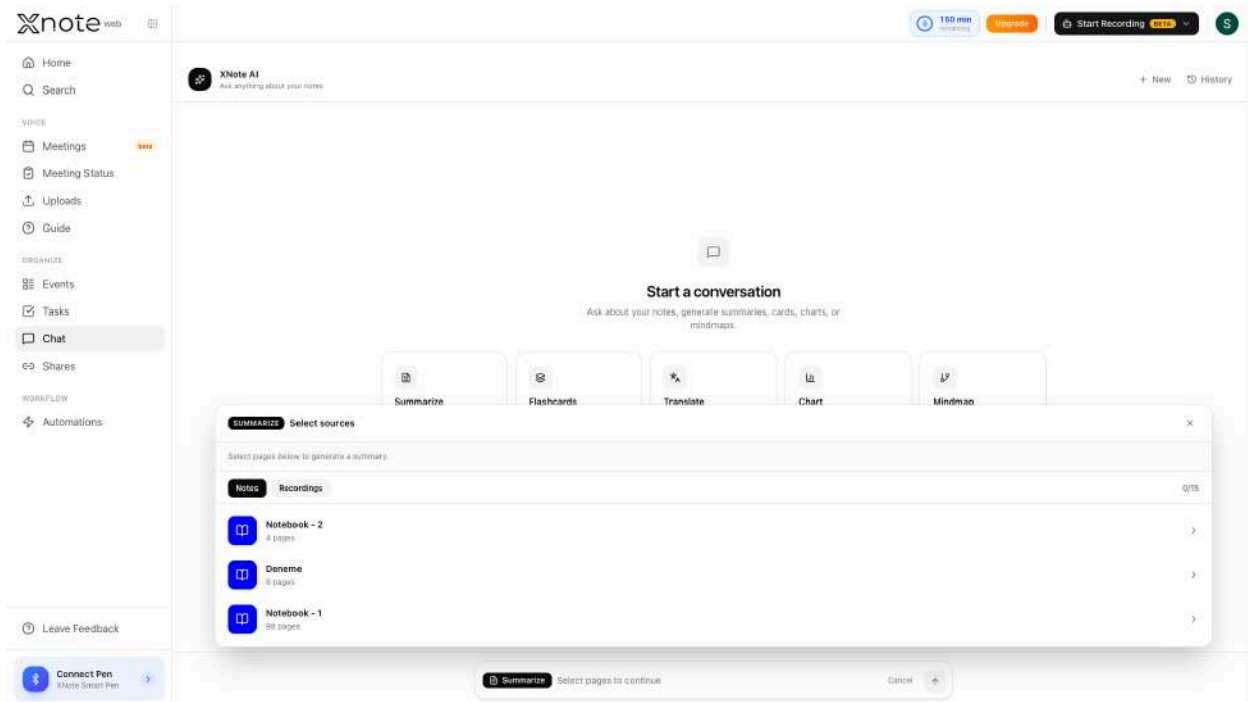

2. Click a notebook to show its pages as a thumbnail grid (2-4 columns).

3. Click pages to select them a blue border and checkmark appear.

4. Selected pages appear as small chips above the input field (e.g., **"P1"**, **"P3"**).

You can mention up to 15 pages per message. A counter shows the current count (e.g., **"3/15"**).

Click X on a chip to remove a page.

- Home
- Search
- Meetings beta
- ORGANIZE
- Events
- Tasks
- Chat
- Shares
- WORKFLOW
- Automations

XNote AI Ask anything about your notes

Small Notebook

15

Handwritten notes on page 15, including a list of items and some paragraphs.

16

Handwritten notes on page 16, featuring a list and a paragraph.

17

Handwritten notes on page 17, with a list and a paragraph.

18

Handwritten notes on page 18, containing a list and a paragraph.

19

Handwritten notes on page 19, with a list and a paragraph.

20

Handwritten notes on page 20, featuring a list and a paragraph.

21

Handwritten notes on page 21, with a list and a paragraph.

P15 X P16 X 2/15

+ Summarize these pages

Connect Pen  
XNote Smart Pen

Press Enter to send, Shift+Enter for new line

### 3.10.3 Summarize

1. Click the Summarize card in the empty state, or click "+" and select "Summarize".
2. The Select sources panel opens with two tabs:
  - Notes : choose a notebook, then click pages to add them.
  - Recordings : choose from your audio sessions (meetings and uploads).
3. You can mix notes and recording.

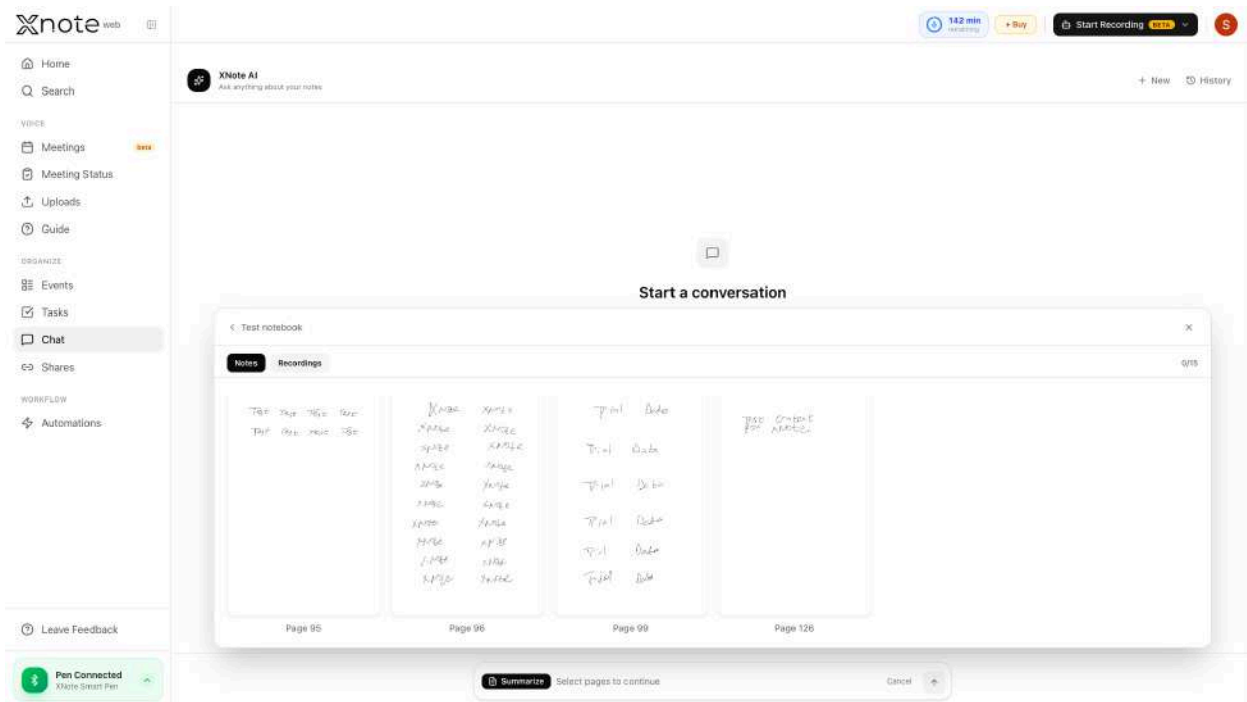

4. AI returns a summary displayed in the conversation.

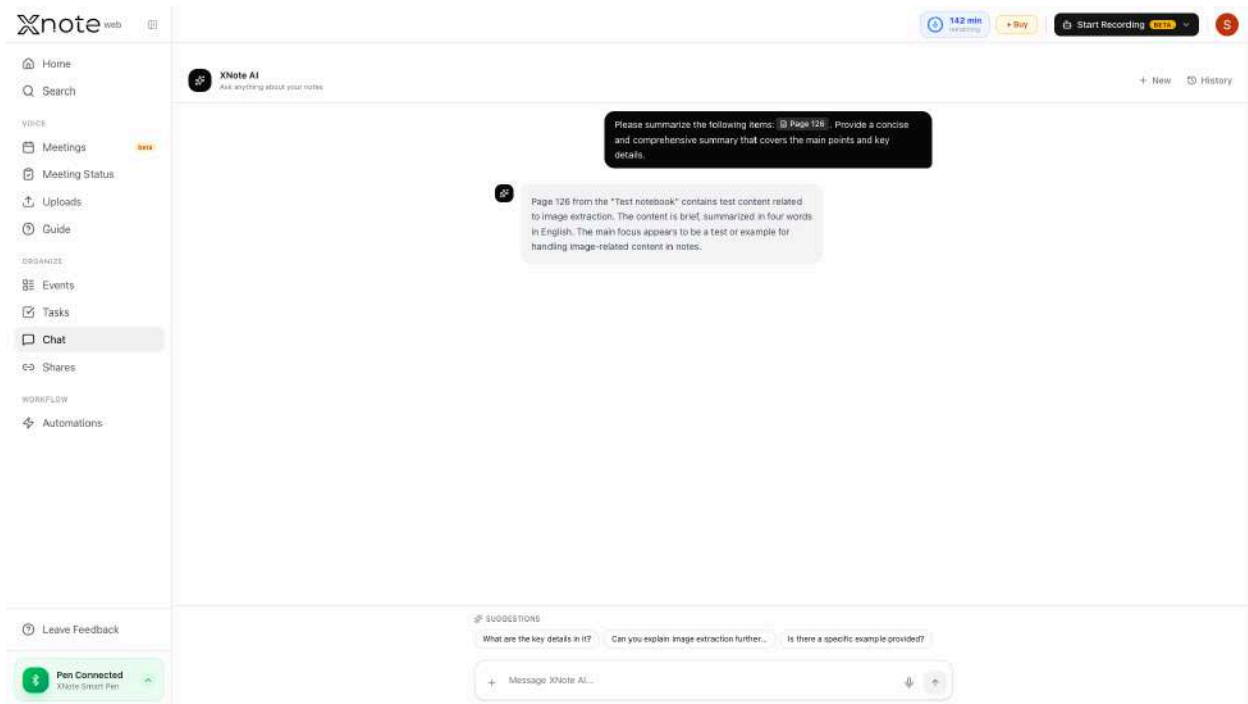

### 3.10.4 Flashcards

1. Click the Flashcards card, or click "+" and select **"Flashcards"**.
2. Choose how many flashcards to generate: 5, 10, 15, 20, or 25. Buttons are displayed in a row.
3. Select sources from the Notes and Recordings tabs — pages and/or recordings, up to 15 total (see [3.10.3](#)).

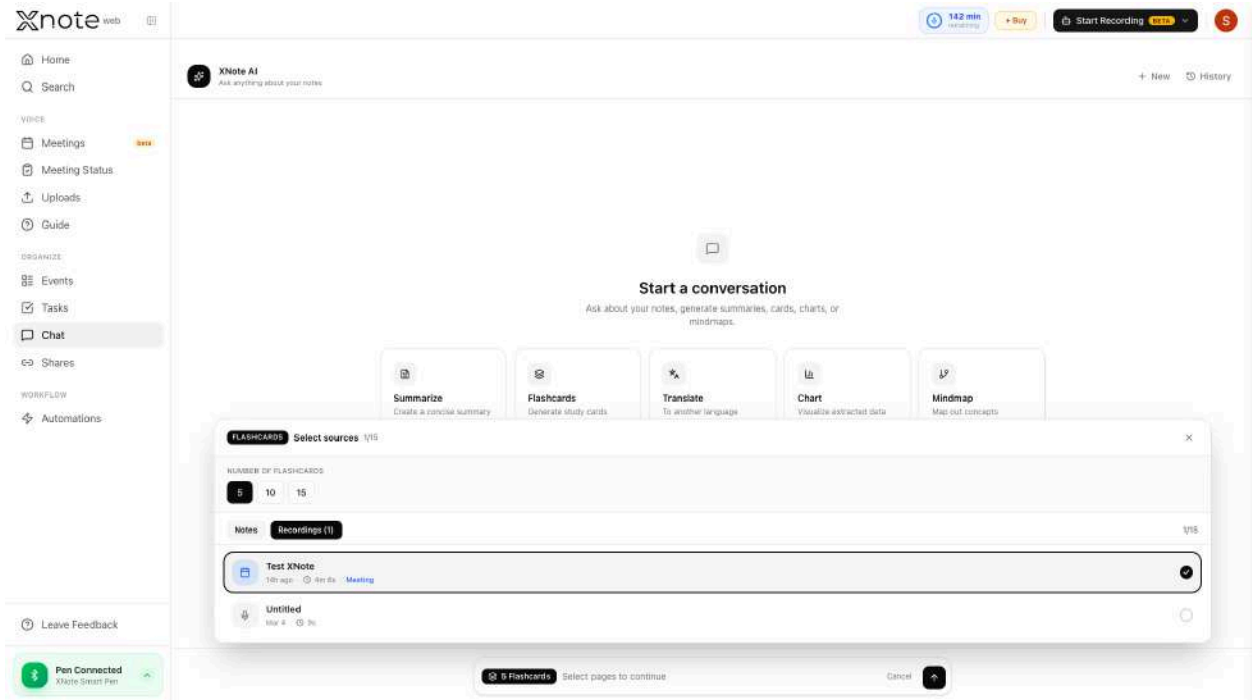

4. AI generates question-and-answer pairs displayed in the conversation.

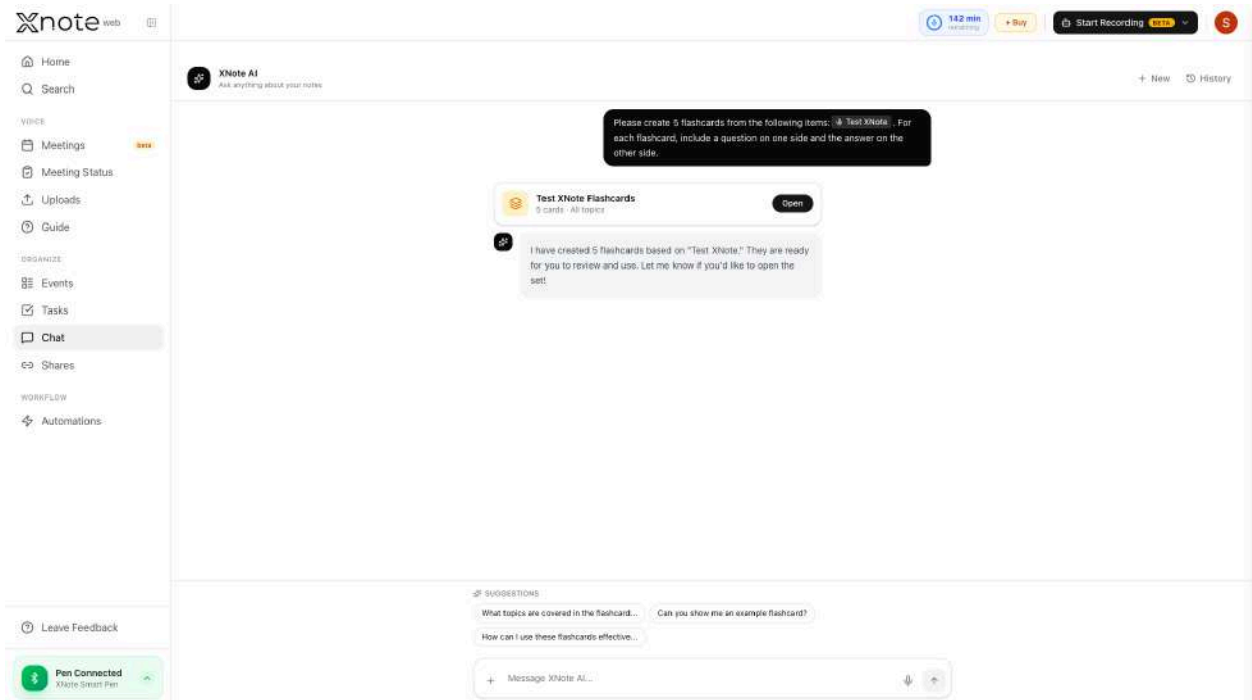

### 3.10.5 Translation

1. Click the Translate card, or click "+" and select "Translate".
2. Search and select the target language from the list (16+ languages with native names). A search input lets you filter languages.

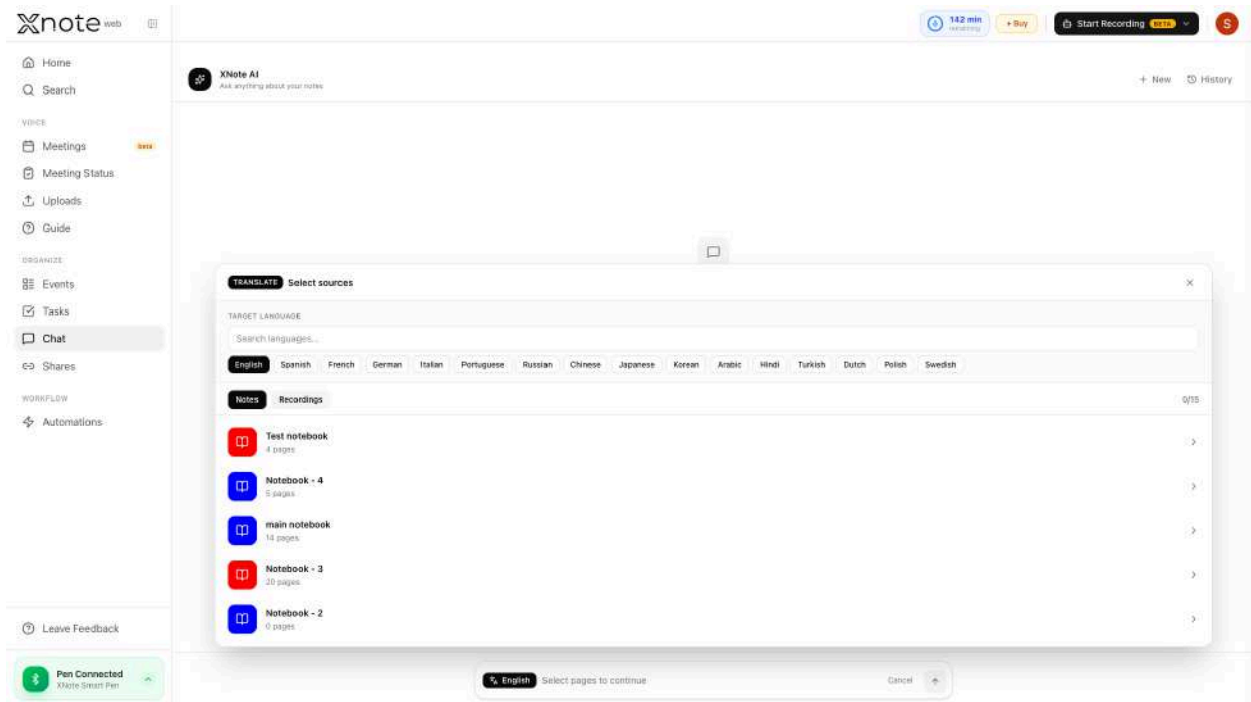

3. Select sources from the Notes and Recordings tabs — pages and/or recordings, up to 15 total (see [3.10.5](#)).

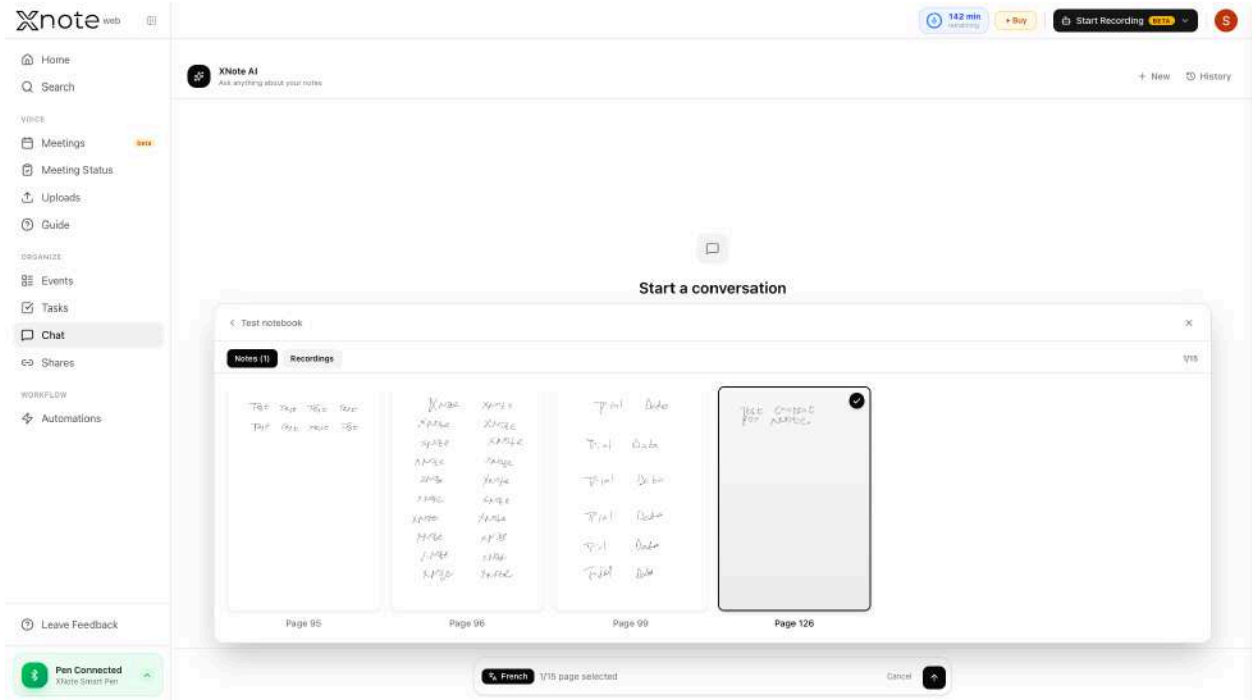

#### 4. AI returns the translated content in the conversation.

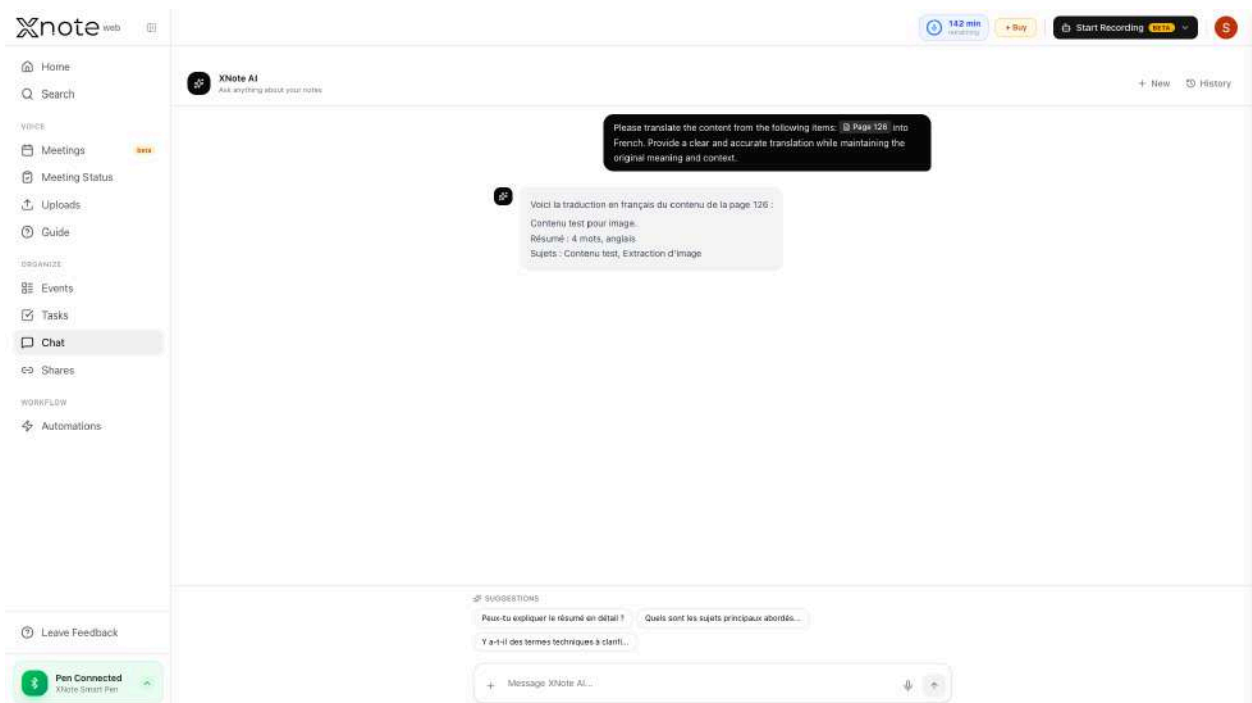

### 3.10.6 Chart Generation

1. Click the Chart card, or click "+" and select "Create Chart".
2. Choose a chart type from the buttons: Bar, Line, Pie, or Scatter.

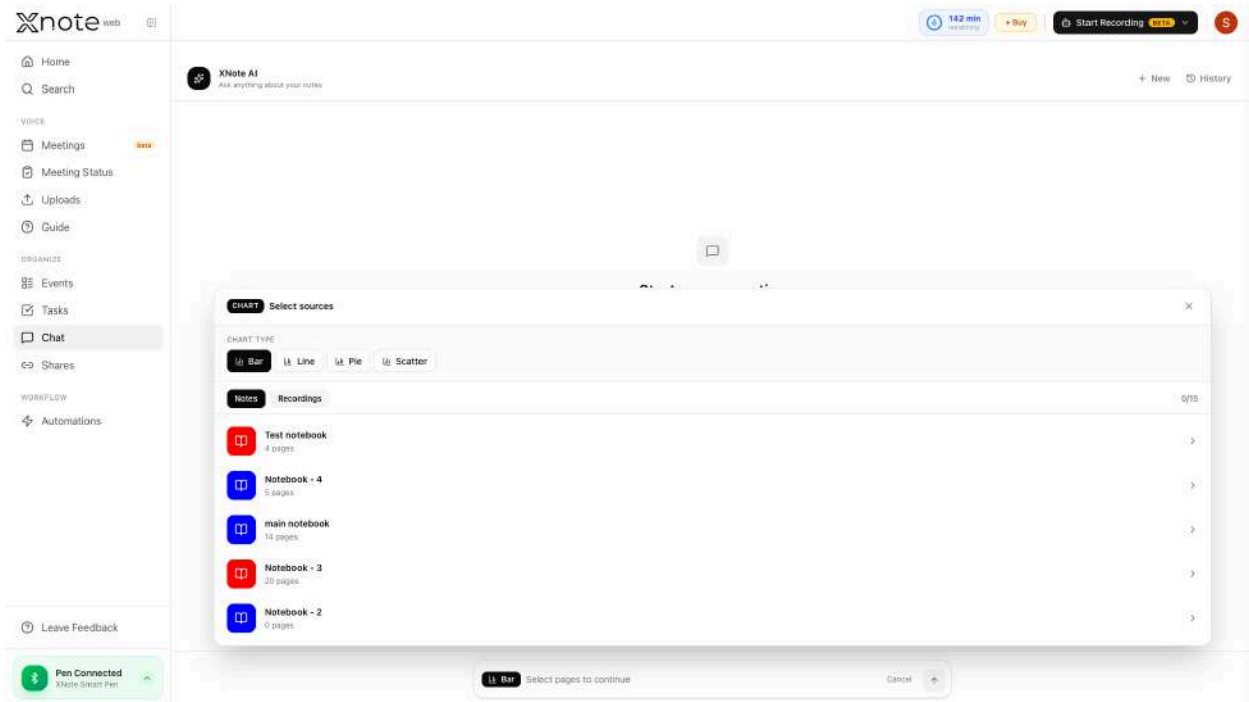

3. Select sources from the Notes and Recordings tabs — pages and/or recordings, up to 15 total (see [3.10.6](#)).

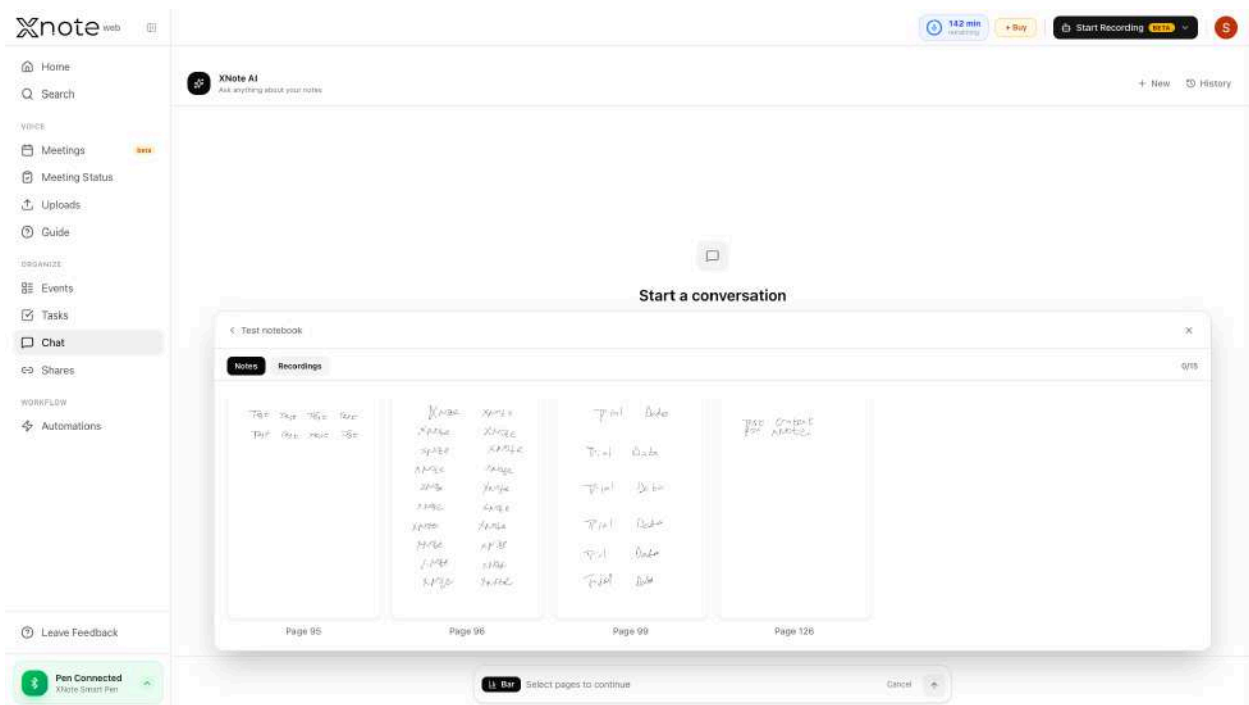

#### 4. AI generates an interactive chart displayed in the conversation with tooltips and legends.

The screenshot displays the XNote AI web interface. On the left is a navigation sidebar with categories like HOME, WORKSPACE, ORGANIZE, and WORKFLOW. The main content area shows a chat conversation. At the top, a system message reads: "Please use the createChart tool to create a bar chart visualization from the data in the following items: Page 99, Page 96". Below this, a tool-generated bar chart is shown. The chart has two bars: a blue bar for "Trial Date" with a value of 12, and a green bar for "Apple Ment..." with a value of 9. A tooltip below the chart states: "This bar chart displays counts of the phrases 'Trial Date' and 'Apple' collected from the respective sources." The AI's response in the chat says: "I have created a bar chart that visualizes the counts of the phrases 'Trial Date' and 'Apple' from the content on Page 99 and Page 96 respectively. The chart shows 12 mentions of 'Trial Date' and 9 mentions of 'Apple.' You can view this bar chart to get a clear comparison. Let me know if you need any other visualizations or details!" At the bottom, there are suggestions for further interaction: "Can you explain the chart's data points?", "What other visualizations can you create...", and "How do I interpret the bar chart?".

142 min remaining | Buy | Start Recording

Home | Search | Meetings | Meeting Status | Uploads | Guide | Events | Tasks | Chat | Shares | Automations

XNote AI - Ask anything about your notes

Please use the createChart tool to create a bar chart visualization from the data in the following items: Page 99, Page 96

Bar Chart

Phrase	Count
Trial Date	12
Apple Ment...	9

This bar chart displays counts of the phrases 'Trial Date' and 'Apple' collected from the respective sources.

I have created a bar chart that visualizes the counts of the phrases "Trial Date" and "Apple" from the content on Page 99 and Page 96 respectively. The chart shows 12 mentions of "Trial Date" and 9 mentions of "Apple." You can view this bar chart to get a clear comparison. Let me know if you need any other visualizations or details!

SUGGESTIONS

- Can you explain the chart's data points?
- What other visualizations can you create...
- How do I interpret the bar chart?

### 3.10.7 Chat History

Click the **"History"** button in the chat header to open the right sidebar.

Past conversations are grouped by time:

- Today
- Yesterday
- This week
- Earlier

Each session shows a sparkles icon (for the current chat) or message icon (for others), chat title, last message preview, and relative time. Use the search bar to find a specific conversation by title. Click a chat to reopen it. Click **"Load More"** at the bottom for older conversations.

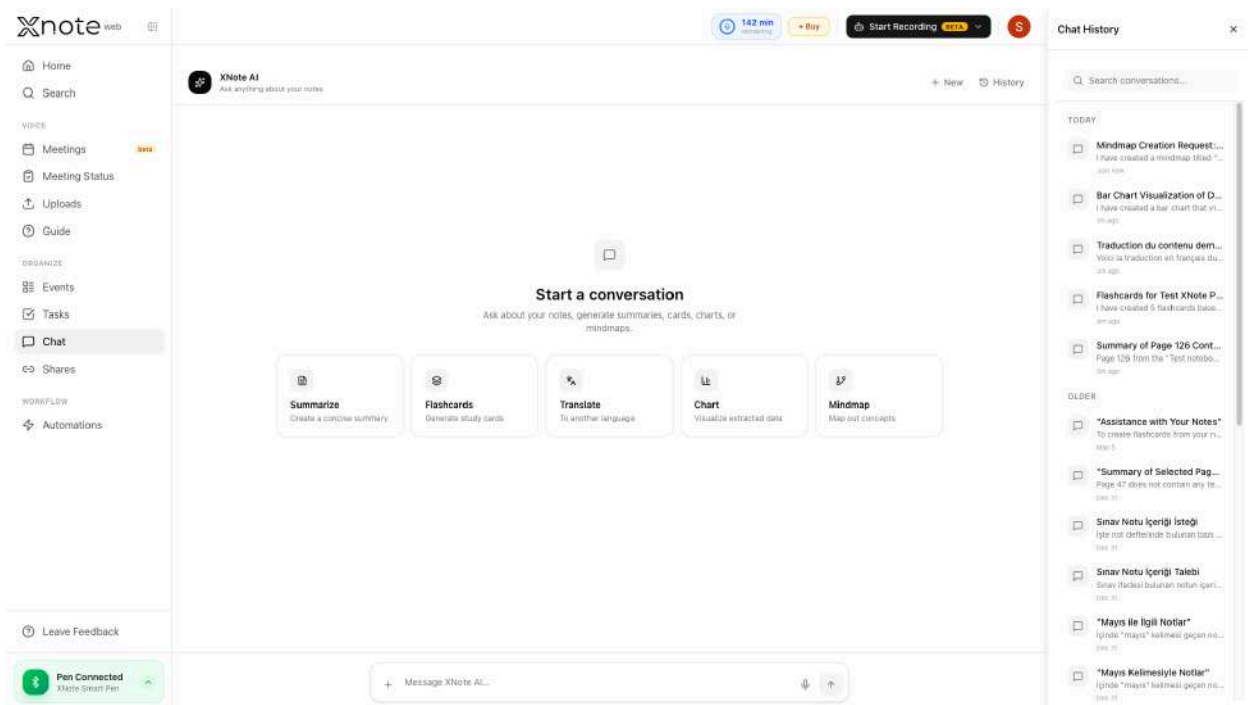

### 3.10.8 Mind Map Generation

Turn your notes into a visual mind map that organizes ideas into a hierarchical structure. A mind map starts from a central topic and branches outward into related subtopics, helping you see connections and group related concepts at a glance.

1. Click the Mind Map card in the empty state, or click "+" and select Mindmap.
2. Choose the tree depth 1, 2, or 3 to control how many levels the map branches out.

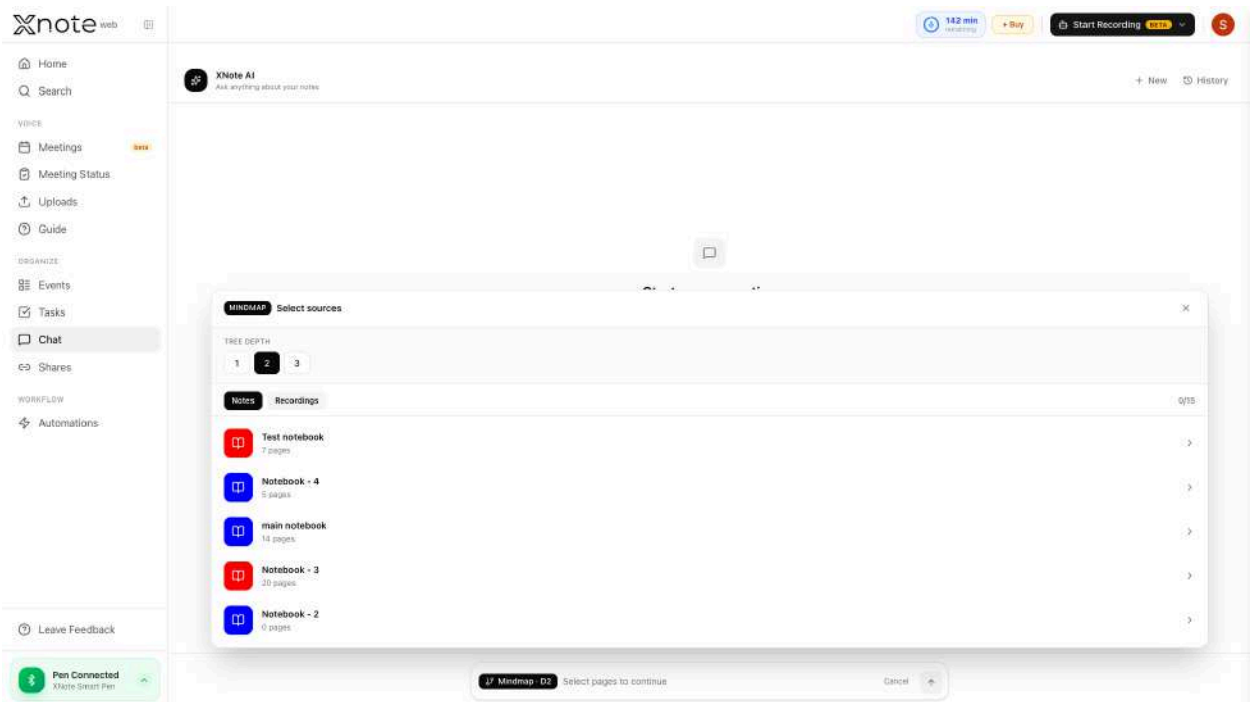

3. Select sources from the Notes and Recordings tabs, pages and/or recordings, up to 15 total AI generates the mind map and displays it in the conversation, with the central topic at the core and subtopics branching outward.

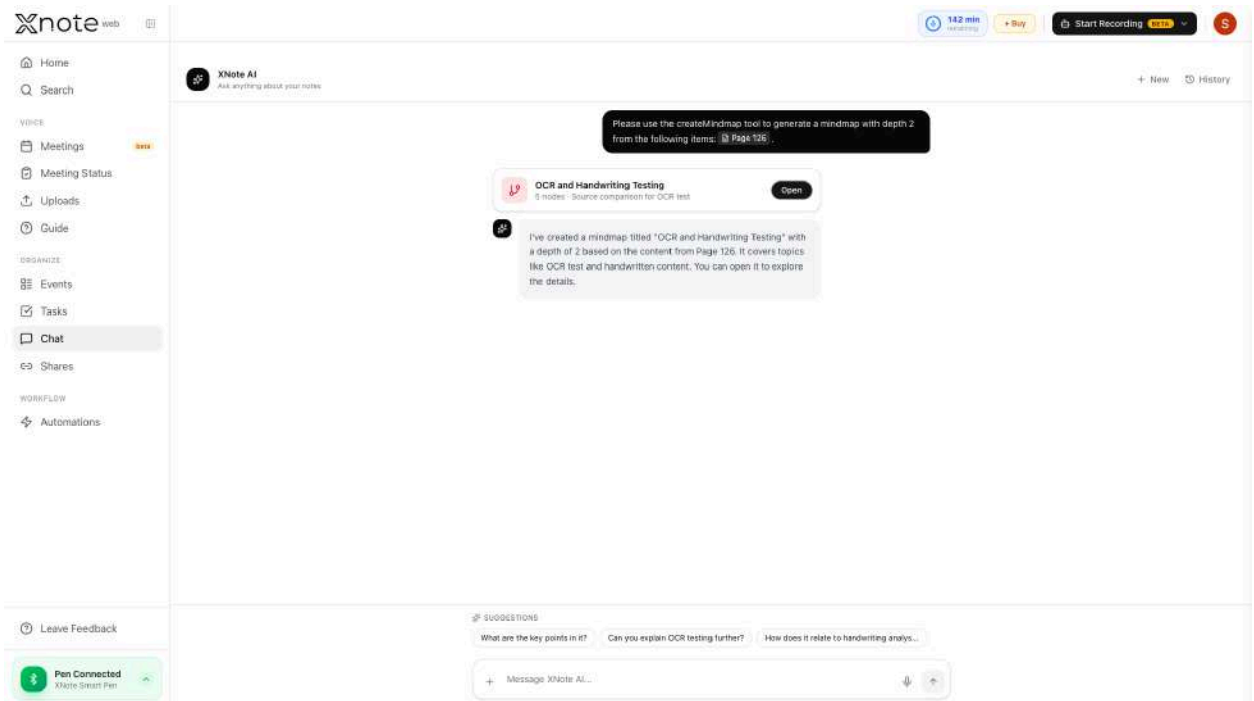
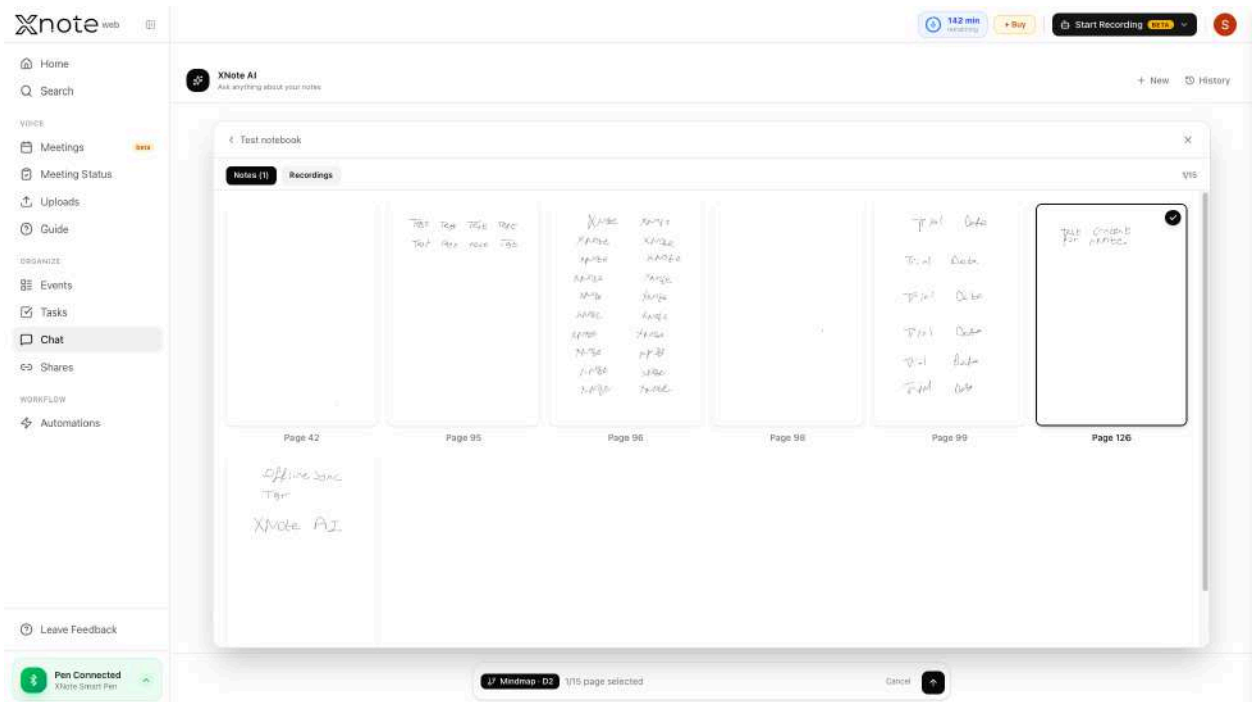

## 3.11 Search

The Search page lets you find pages across all your notebooks using text, topics, or tags. The same three-section home screen as mobile: Recent Searches, Tags, and Topics.

When a search or filter is active, an inline badge shows **"Showing results for: [query/topic/tag]"**.

### 3.11.1 Full-Text Search

Enter at least 2 characters in the search bar. Results appear as a responsive grid of page thumbnails (up to 5 columns), each showing the page preview, page number, and notebook title.

Click a result to open the page.

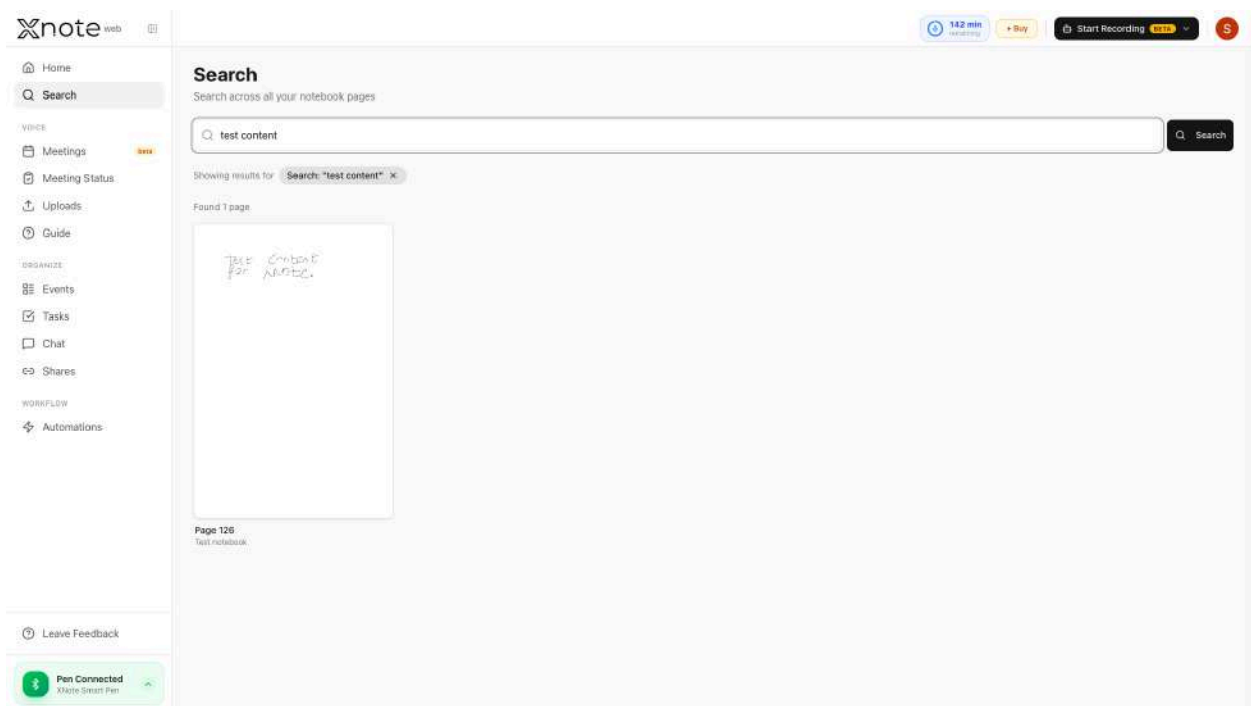

### 3.11.2 Topic-Based Search

Below the search bar, topic chips show frequently occurring topics extracted by AI. Each chip displays the topic name and page count.

Click a topic to view all related pages. Click "See all" to expand the full topic list. Click the topic again to deselect.

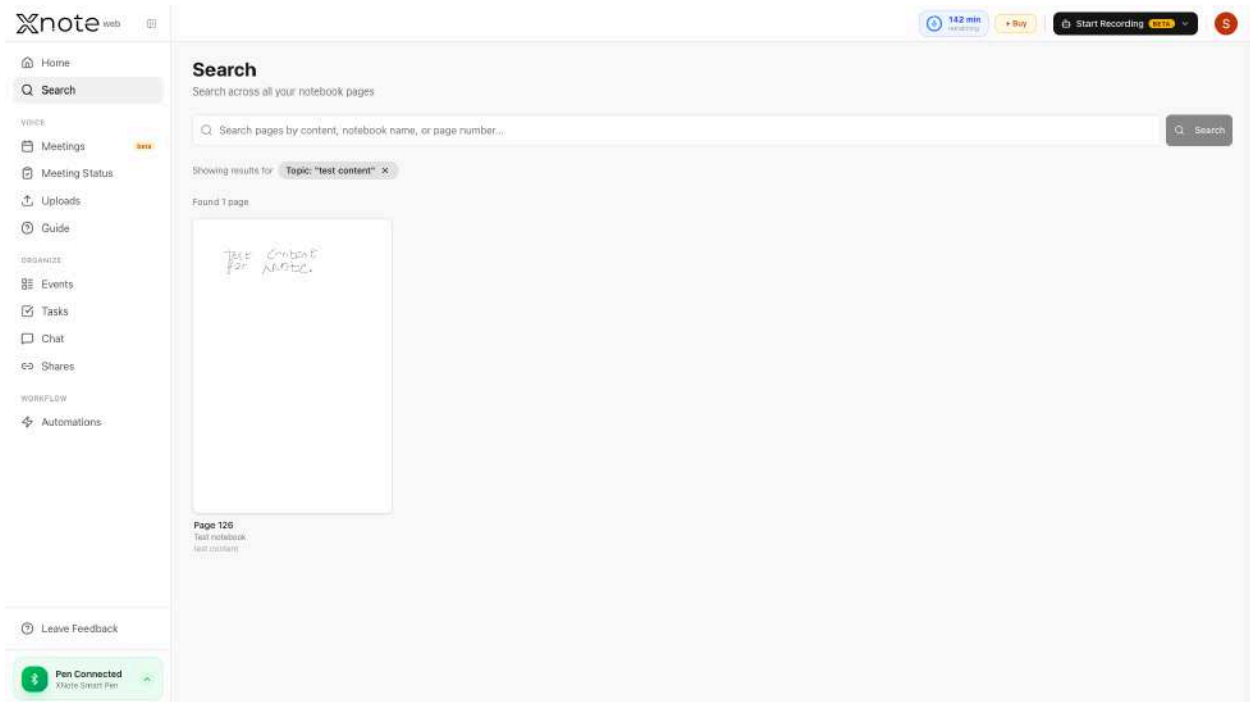
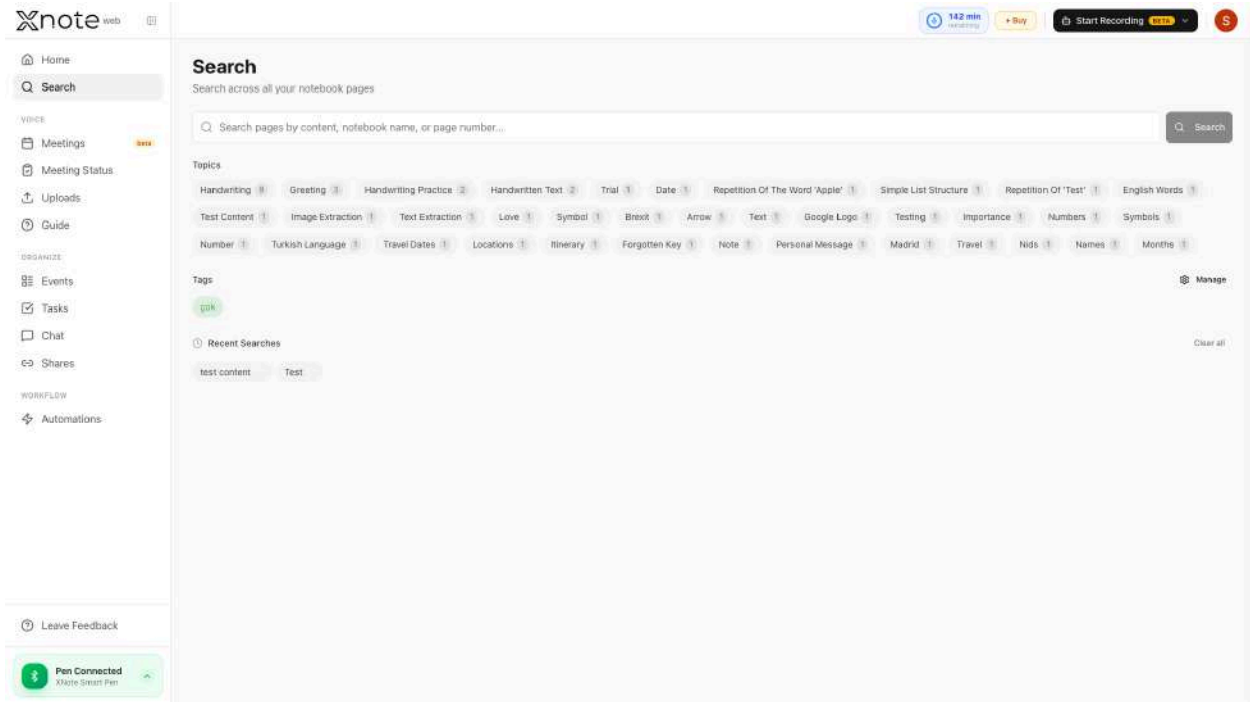

### 3.11.3 Tag-Based Filtering

Your tags are displayed as colored chips. Click a tag to filter pages by that tag.

Click **"See all"** to browse all tags. Use the Tag Management dialog to create, edit, or delete tags (name + color from 12 presets).

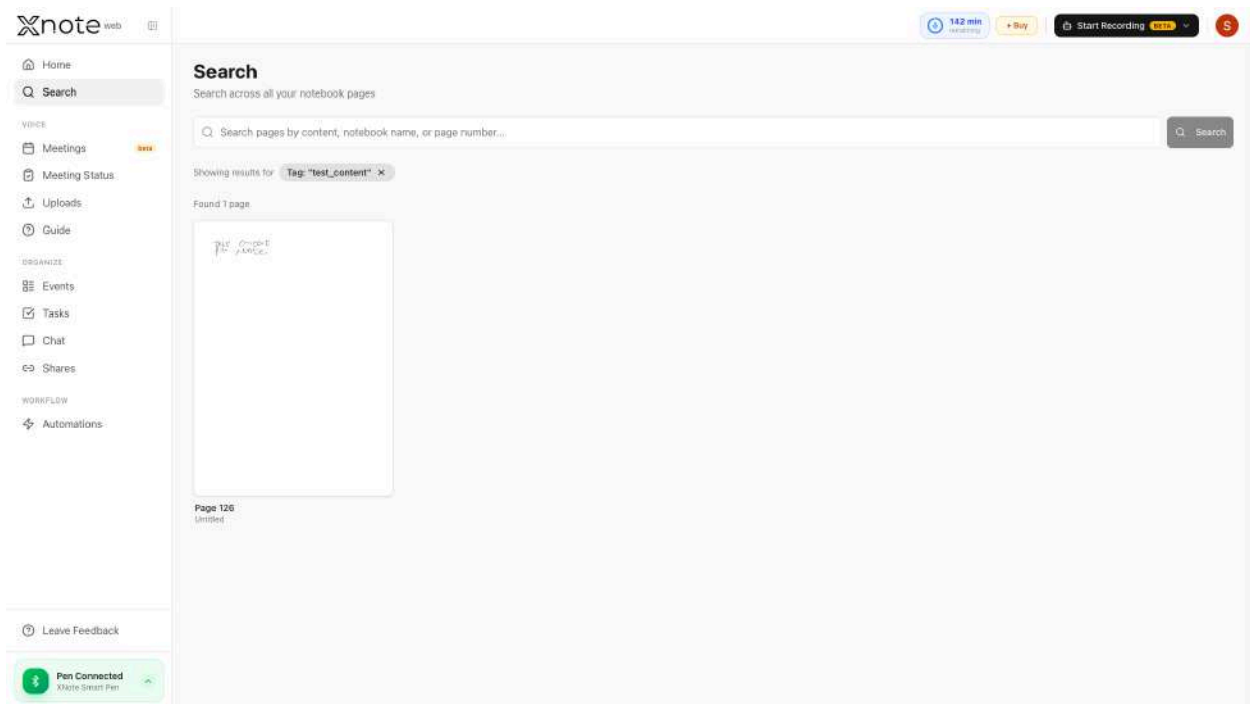
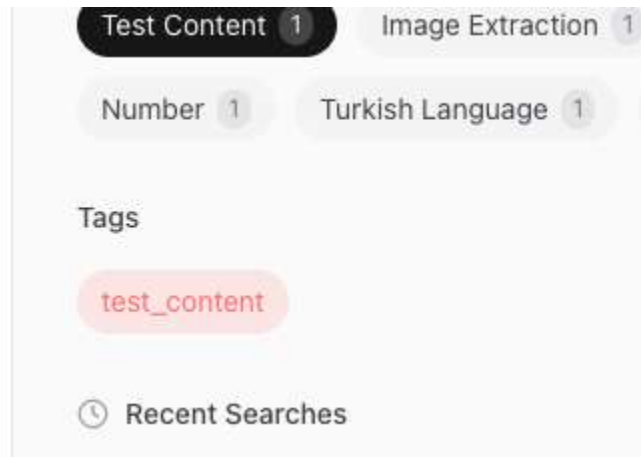

### 3.11.4 Recent Searches

Recent searches appear as clickable chips when no search is active (up to 10 stored). Click a chip to re-run the search. Click X to remove one, or **"Clear all"** to remove all.

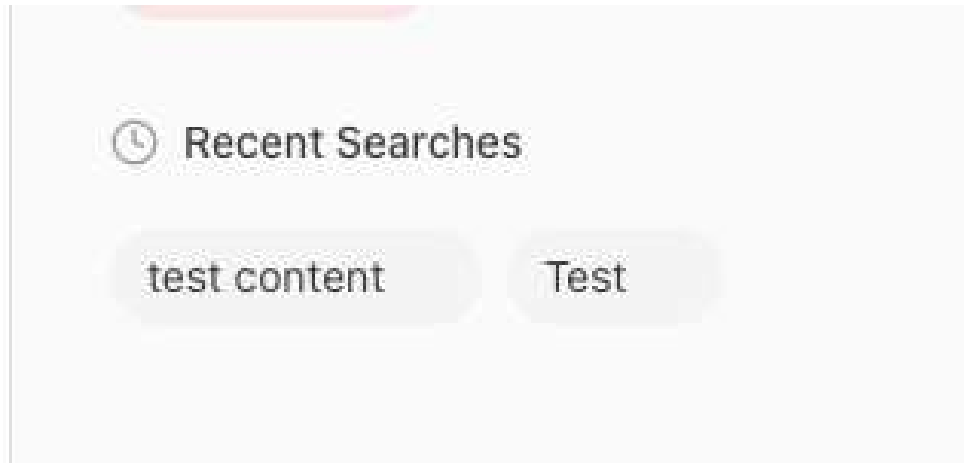

## 3.12 Tasks

The Tasks page displays all your tasks with statistics and filtering controls.

### 3.12.1 View & Filter Tasks

At the top, four stat cards show counts for: To Do, Completed, Overdue, and High Priority, each with a color-coded background. A progress bar shows overall completion percentage.

Tasks are displayed in a responsive grid (up to 4 columns). Each card shows:

- Task emoji or source icon
- Description
- Priority badge (High / Medium / Low)
- Due date (red if overdue)
- Todoist sync indicator
- Checkbox for completion

Filter by status: To Do (default), Done, or All using the tab buttons at the top.

The screenshot displays the Xnote web application interface. At the top left, the Xnote logo and 'web' are visible. The top right corner shows a recording timer at 142 minutes, a '+ Buy' button, a 'Start Recording' button, and a user profile icon. The main header area features a 'Good Morning, Test!' greeting and a 'Share Feedback' link. Below this is a notification banner titled 'What is a Primary Notebook?' explaining that users can set a primary notebook for each size (Mini, Standard, Large) and that notes are saved to the primary notebook of that size. The central area is divided into 'Notebooks' and 'Folders' sections. The 'Notebooks' section displays five notebook cards: 'Test notebook' (Mini, 8 / 144 pages), 'Notebook - 4' (Large, 5 / 192 pages), 'Notebook - 2' (Standard, 0 / 192 pages), 'Notebook - 3' (Mini, 20 / 144 pages), and 'main notebook' (Mini, 14 / 144 pages). To the right of these cards are buttons for 'New Notebook' and 'View All 8 notebooks'. Below the notebooks is a 'Recent Meetings' section with two recordings: 'Social Media Impact' (Test Xhite, 15 hours ago) and 'Untitled' (Mar 4, 3:03 PM - 9s). The 'Tasks' section shows two remaining tasks: 'Send email to customs' and 'Finish the project reports'. On the right side, there is a '0 Upcoming' section with a 'View all' link. The left sidebar contains navigation options: Home, Search, Voice (Meetings, Meeting Status), Uploads, Guide, Organize (Events, Tasks, Chat, Shares), and Workflow (Automations). At the bottom left, there is a 'Leave Feedback' button and a 'Pen Connected' notification for the Xhite Smart Pen.

### 3.12.2 Create / Edit / Delete Tasks

Tasks are primarily created automatically from audio recordings (AI-extracted action items) and page content.

Click a task card to open the detail modal showing:

- Full title and description
- Priority and due date
- Source link (recording or notebook page)
- Actions: Send to Todoist, Delete

To delete, click the trash icon on hover or in the detail modal. A confirmation dialog will appear.

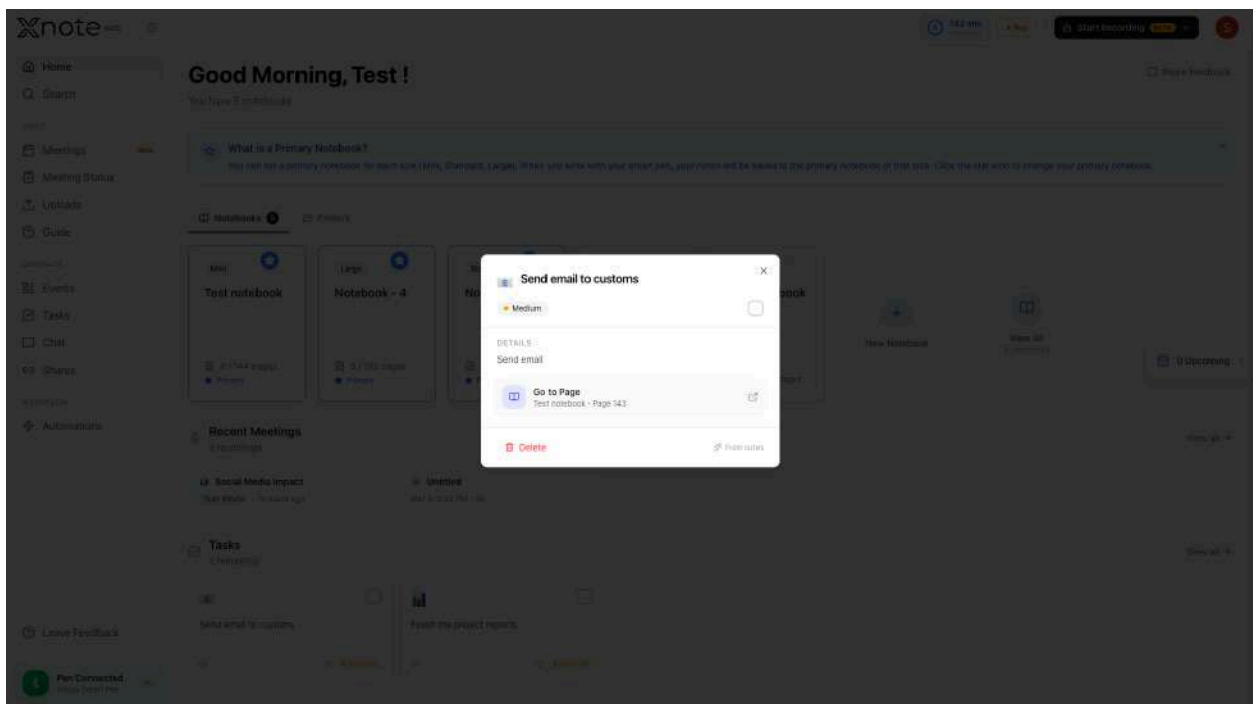

### 3.12.3 Sort & Search Tasks

Search: Use the search bar to filter tasks by title or description.

Sort options (dropdown with direction toggle):

- Due Date
- Priority (High to Low / Low to High)
- Created (Newest / Oldest)
- Title (A-Z / Z-A)

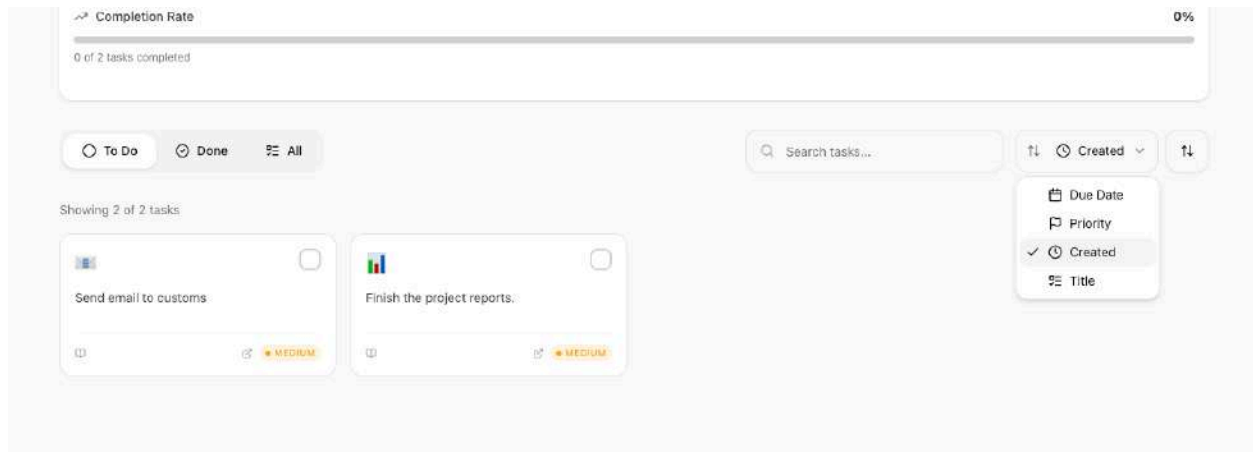

### 3.12.4 Todoist Integration

Connect your Todoist account from Settings -> Integrations.

To sync a task to Todoist:

1. Hover over a task card and click the Todoist icon, or click **"Send to Todoist"** in the detail modal.

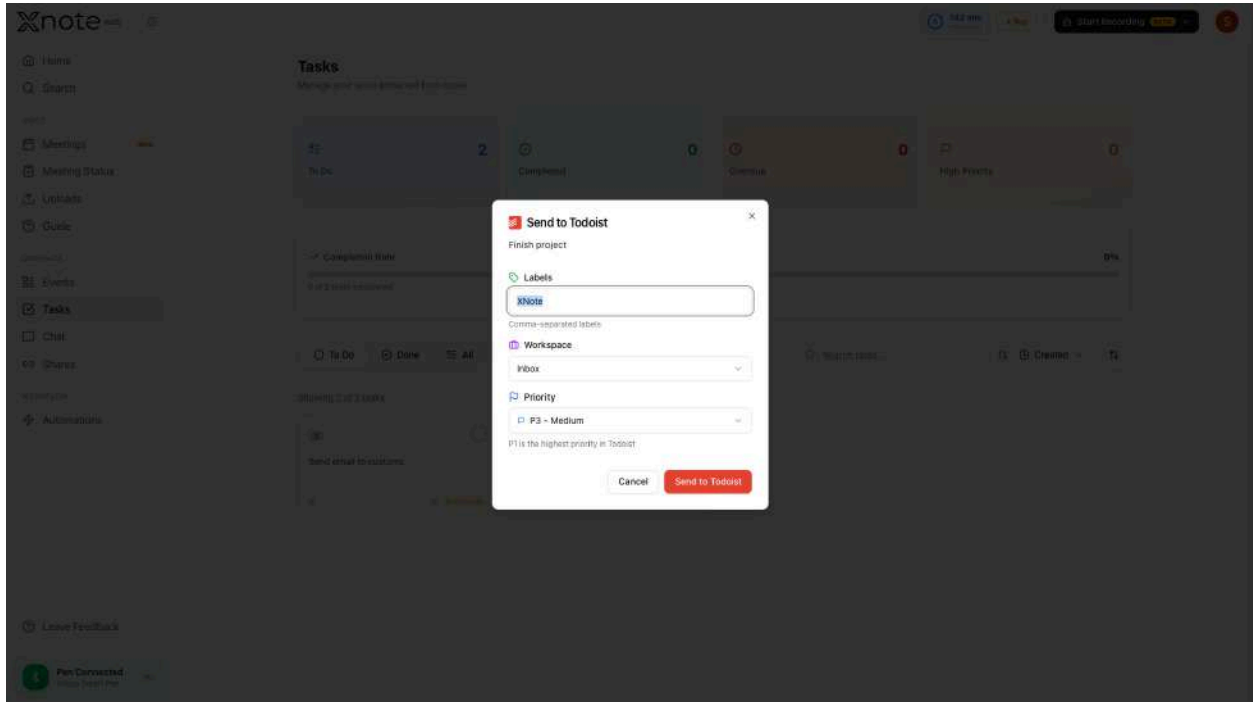

2. Select your workspace, set priority (P1-P4), and add labels.

3. Click **"Send"**.

Synced tasks show a Todoist badge. Completing a task in XNote updates its status in Todoist automatically.

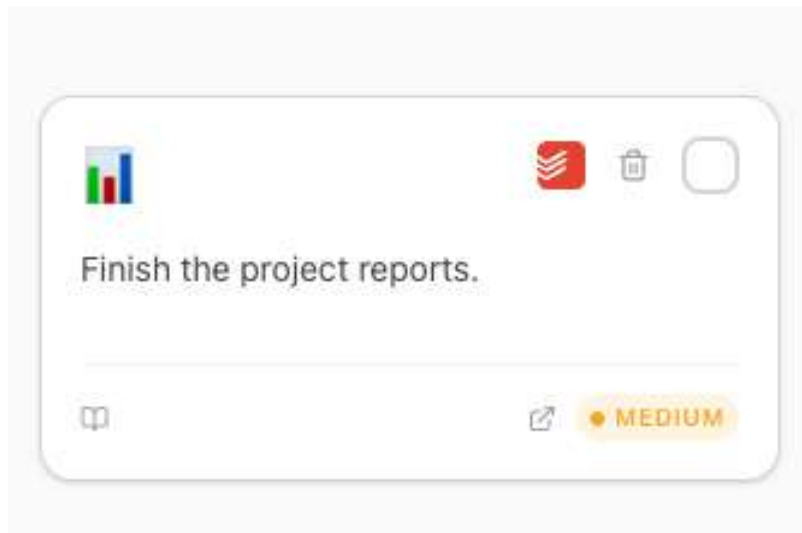
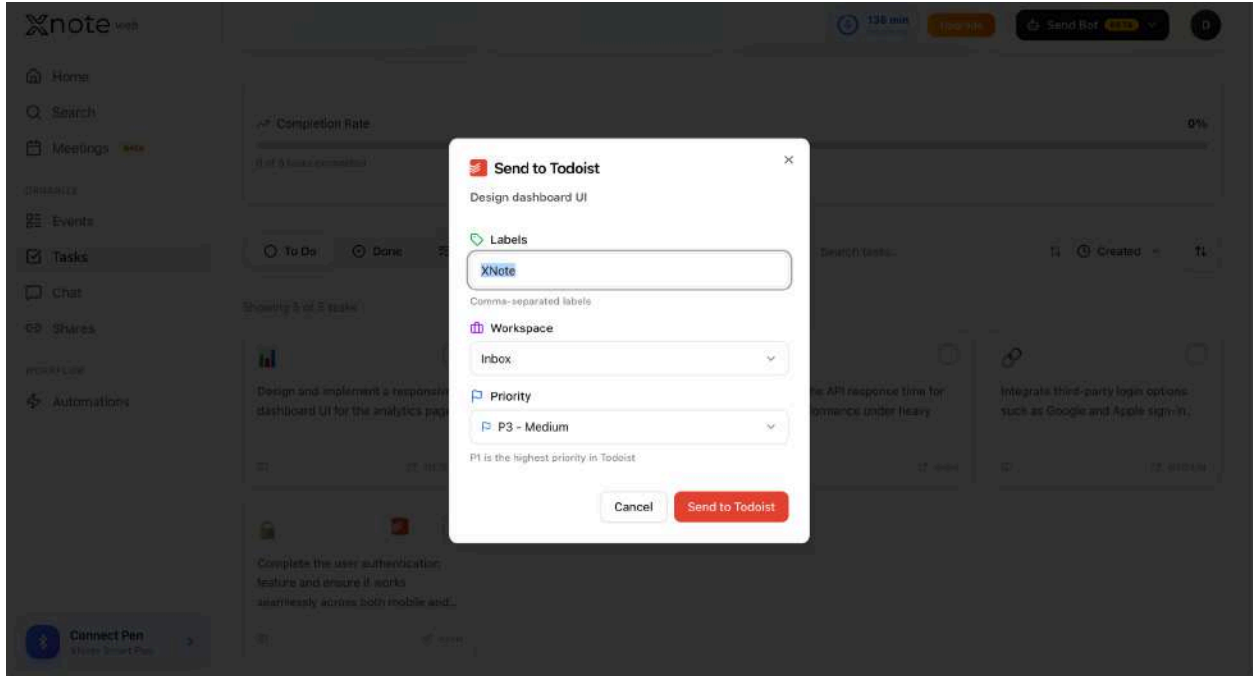

## 3.13 Events & Calendar

The Events page shows your calendar events and lets you schedule recording bots for online meetings.

### 3.13.1 Calendar View & List View

Two views are available, toggled from the header:

**Calendar View (default):** A rich monthly calendar grid showing events on each day. Events are color-coded: orange for XNote events, green for completed recordings, red for active recordings, purple for scheduled bots.

**List View:** Events grouped by week with collapsible sections.

You can search across all events using the search box. Filter toggles let you show or hide: Recordings, Meetings, and Calendar Events separately.

The screenshot displays the Xnote web interface. At the top, there's a navigation bar with the Xnote logo, a search box, and several utility buttons like '142 min', '+Buy', and 'Start Recording'. Below the navigation bar, there are tabs for 'Calendar' and 'List', and a search box for events. The main content area shows a monthly calendar grid for June 2026. The grid is color-coded: orange for XNote events, green for completed recordings, red for active recordings, and purple for scheduled bots. The calendar shows events for each day, including XNote tests, business meals, and holidays like Flag Day and Independence Day. The sidebar on the left contains navigation options like Home, Search, Meetings, Meeting Status, Uploads, Guide, Events, Tasks, Chat, Shares, and Automations. At the bottom left, there's a 'Pen Connected' notification for the Xnote Smart Pen.

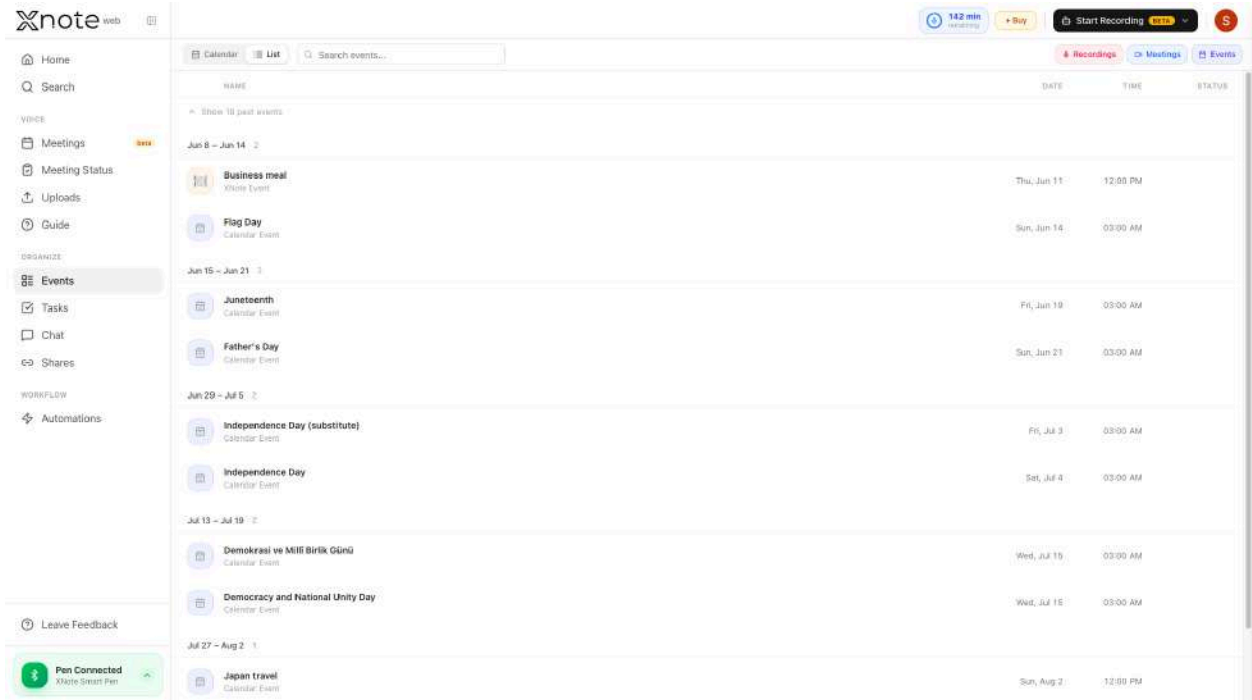

### 3.13.2 Google Calendar Integration

1. On the Calendar page, click "Connect Google Calendar".

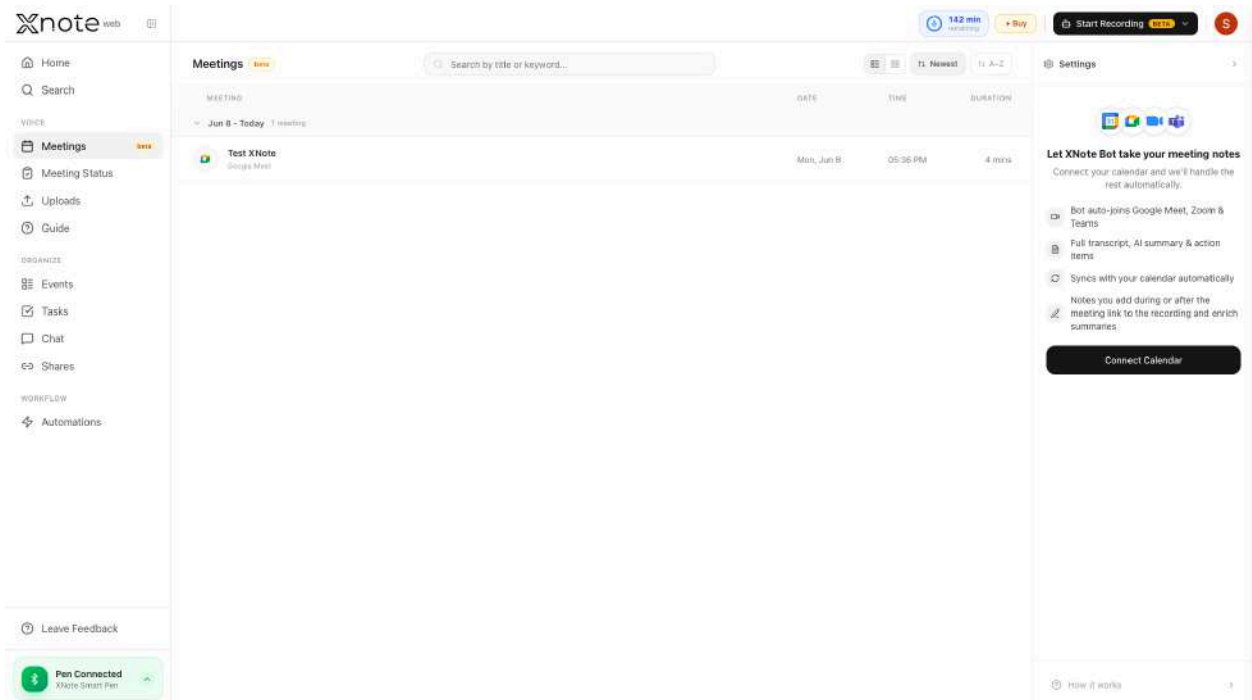

2. Sign in with your Google account in the popup window.

3. After successful connection, you will be prompted to enable Auto-Record.

Once connected, configure your bot settings (displayed inline on the calendar page):

- Bot Name : Custom name shown in meetings
- Transcription Language : 14+ languages including auto-detect
- Summary Email Preference : Only Me, All Attendees, or Don't Send
- Auto-Record Toggle : Automatically record all meetings

The screenshot displays the Xnote web interface. On the left is a sidebar with navigation options: Home, Search, Meetings (selected), Meeting Status, Uploads, Guide, Events, Tasks, Chat, Shares, and Automations. The main content area is titled 'Meetings' and features a search bar and a table of meetings. A notification at the top indicates 'Google Calendar connected successfully!' and a prompt to 'Enable Auto-Record?'. The table shows one meeting: 'Test XNote' on 'Mon, Jun 8' at '05:36 PM' for '4 mins'. On the right, the 'Settings' panel is open, showing the user 'sali@xnote.ai', an 'Auto-Record' toggle, a 'Bot Name' field with 'XNote Note Taker', a 'Language' dropdown set to 'Auto-detect', a 'Summary Email' dropdown set to 'Only Me', and a 'Summary Template' dropdown set to 'Varsayilan'. A 'Disconnect Calendar' link is also visible.

MEETING	DATE	TIME	DURATION
Test XNote Google Meet	Mon, Jun 8	05:36 PM	4 mins

### 3.13.3 Event Details

Click an event to open the detail modal showing:

- Event title and meeting provider (Zoom, Google Meet, Teams)
- Start/end time with relative countdown
- Attendees with response status (Accepted, Declined, Tentative, Pending)
- Meeting link with **"Join Meeting"** button
- Bot recording status with real-time updates and action buttons (Stop, Cancel)

If a recording is completed, click to view the audio session.

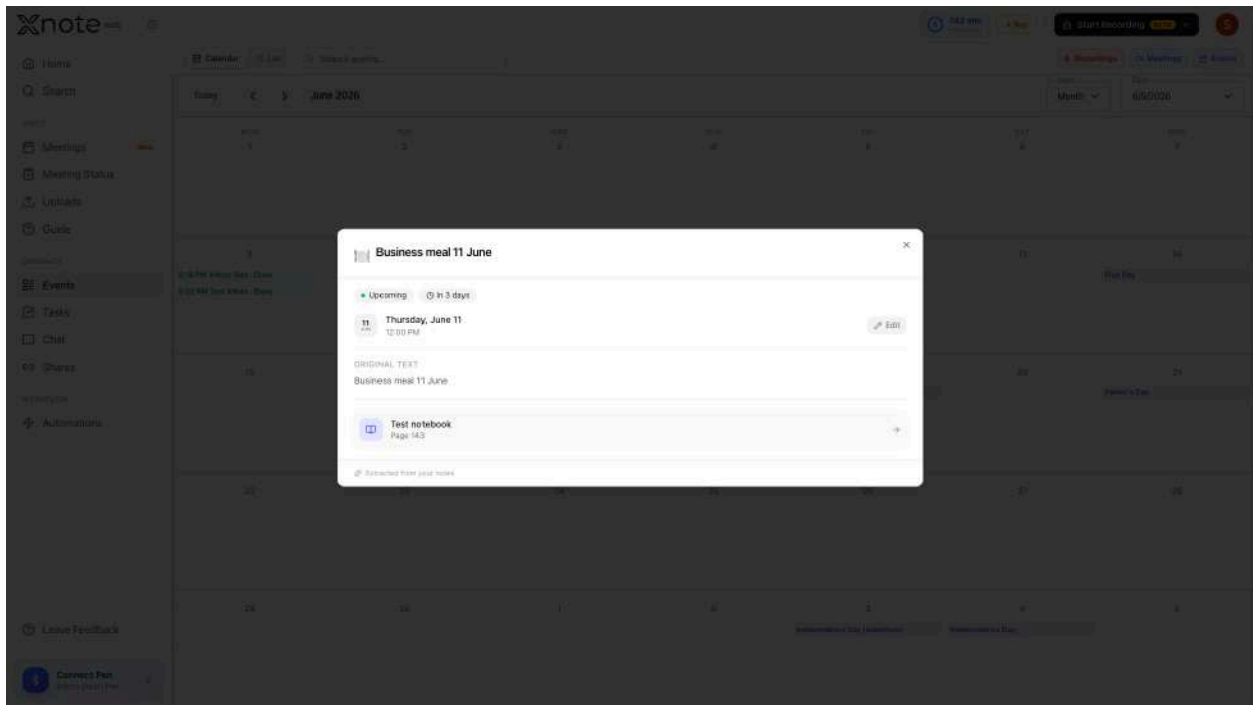

### 3.13.4 Meeting Bot Scheduling

Per-event scheduling:

In the event detail modal, toggle Auto-Record on for that specific event. Select the transcription language if needed.

Global auto-record:

On the Calendar settings, enable the global auto-record toggle. All future events with meeting links will be recorded automatically.

The bot status updates in real-time: Scheduled -> Joining -> Waiting Room -> Recording -> Completed.

## 3.14 Automations

Automations let you create rules that automatically perform actions when certain events occur in XNote.

Important: Automation availability depends on your plan ([see Section 4.1 for plan limits](#)). When the limit is reached, an **"Upgrade to unlock workflows"** button appears.

### 3.14.1 View Automations

The Automations page shows your automations as cards. Each card displays:

- Automation name and trigger type
- Action service badges with connection status (green = connected, gray = disconnected)
- Enable/disable toggle
- Three-dot menu for Edit and Delete

Header buttons:

- History : Opens the execution history panel ([see 3.14.6](#))
- Services : Opens the connected services page ([see 3.14.5](#))

If you have no automations, the Templates section is shown first to help you get started.

The screenshot displays the XNote web interface. On the left is a sidebar with navigation links: Home, Search, MEETING (Meetings, Meeting Status), Uploads, Guide, ORGANIZE (Events, Tasks, Chat, Shares), and WORKFLOW (Automations). The main content area has a top navigation bar with '142 min', 'Buy', 'Start Recording', and a profile icon. Below this is a banner for Zapier integration. The 'Automations' section shows 'Automate your workflows with triggers and actions' with buttons for 'History', 'Services', and 'New Automation'. Under 'My Automations', there is one active automation: 'Event Planning Assistant' (Event Created) with a description 'Create calendar events and notify team about travel plans' and a toggle switch. Below this is the 'Templates' section, categorized by 'All Templates', 'Productivity', 'Notifications', and 'Organization'. It features four template cards: 'Event Planning Assistant' (Organization), 'Weekly Backup Automation' (Organization), 'Emergency Alert' (Notifications), and 'Task Creation Tracker' (Product). Each card includes a brief description and a 'Use Template' button.

### 3.14.2 Create an Automation

Click "+ New Automation" to open a 4-step wizard dialog:

Step 1 : Basic Info: Enter a name (required) and description (optional).

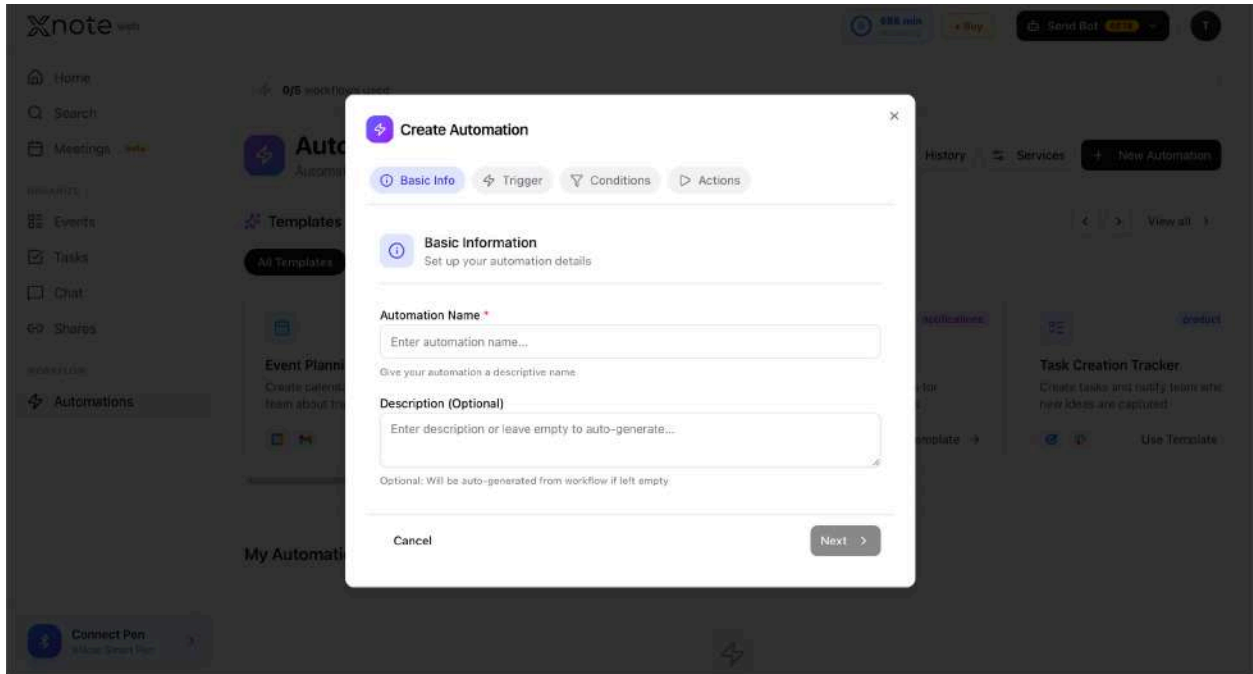

Step 2 : Trigger: Choose what starts the automation:

- Note Updated
- Task Created / Completed
- Event Created / Updated
- Time-Based (with schedule: Daily, Weekly, or Monthly + time picker)

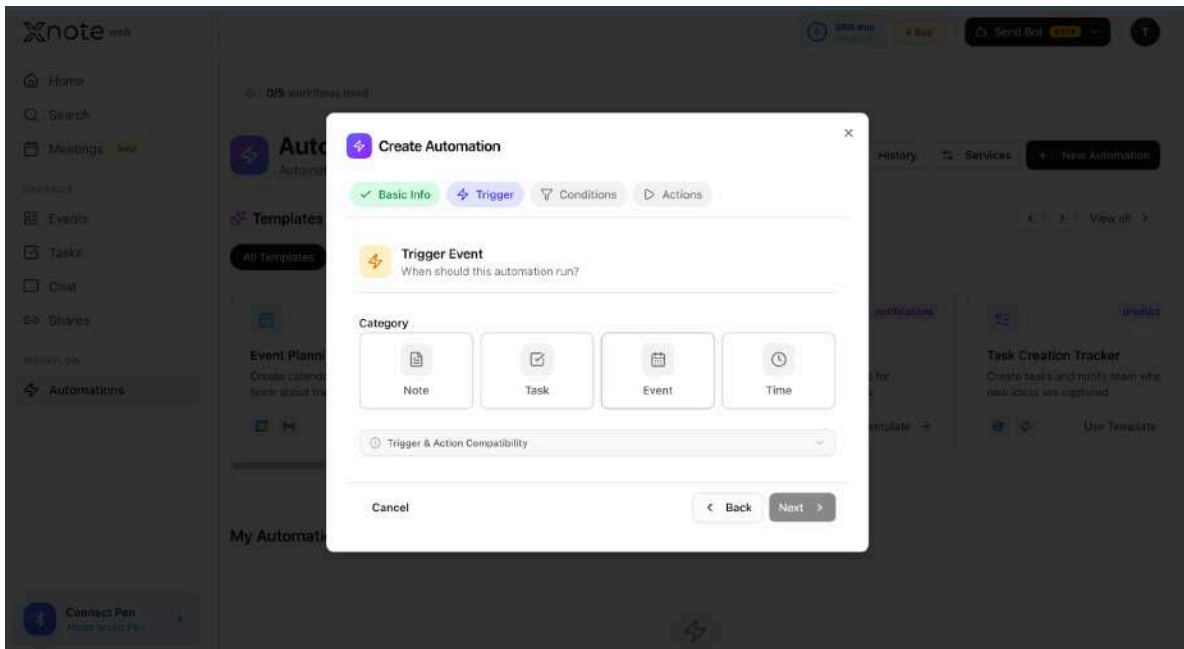

Step 3 : Conditions: Optionally add a condition (text contains, task priority, or no condition).

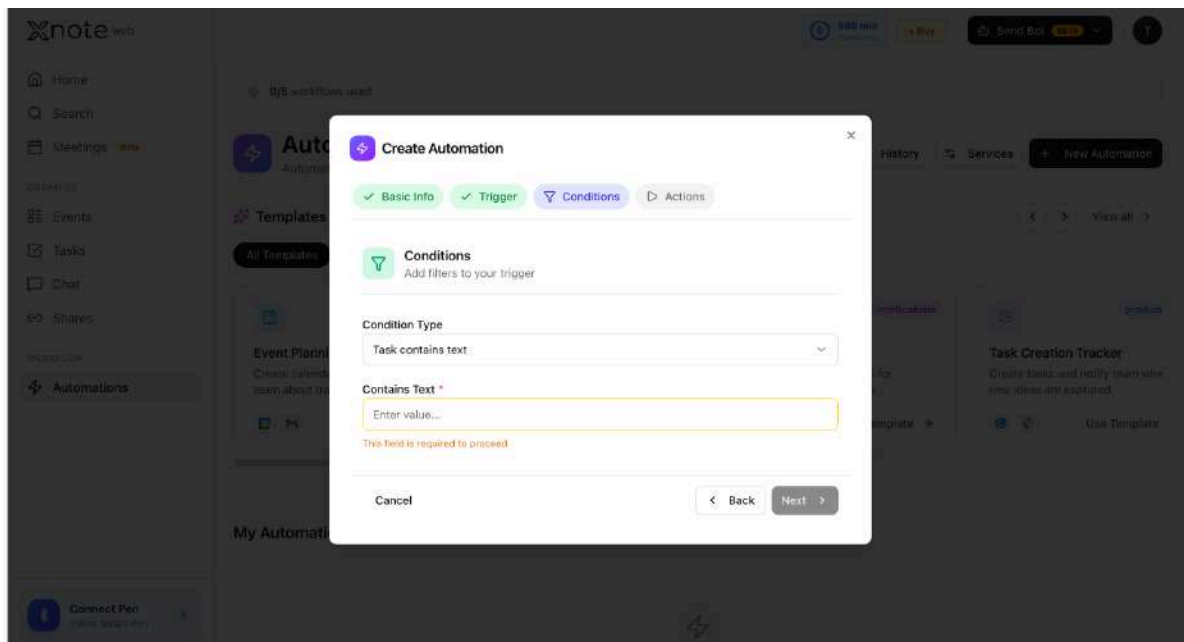

Step 4 : Actions: Select and configure actions:

- Gmail, Google Drive, Google Calendar, Google Tasks, Slack
- Each action shows its connection status. Click **"Configure"** to set up recipients, content, and details.

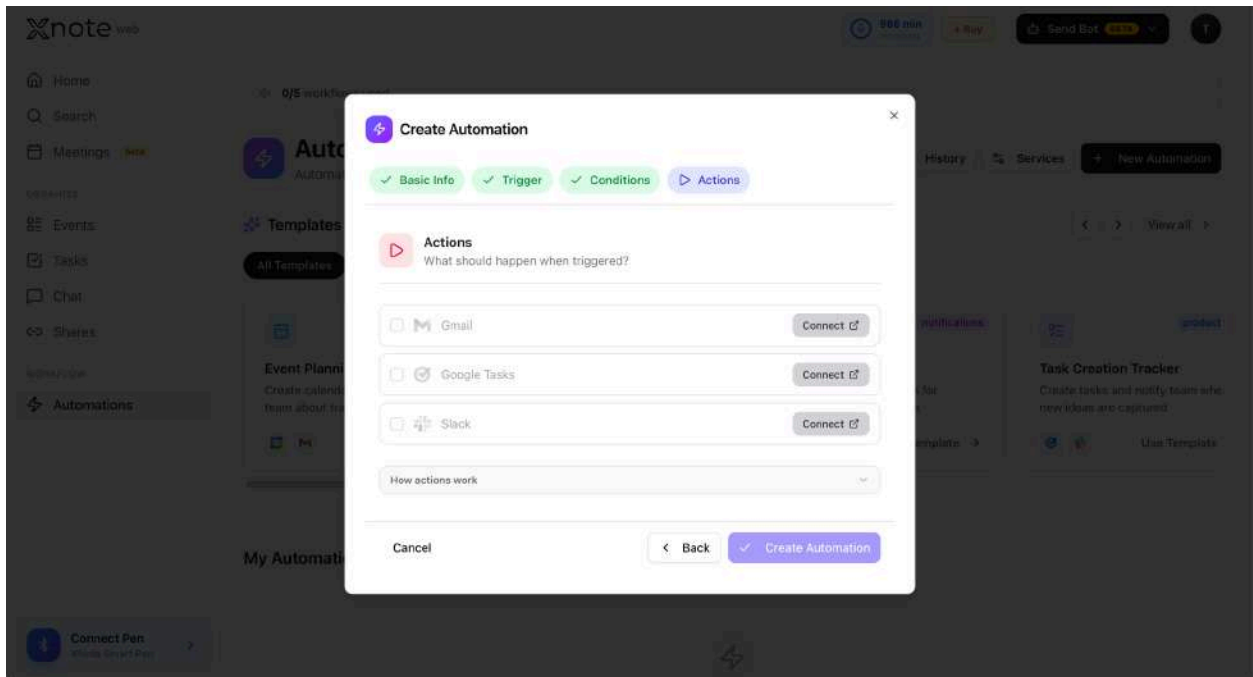

### 3.14.3 Edit an Automation

To edit an existing automation, click the three-dot menu on its card and select **"Edit"**. The same wizard opens with your current settings pre-filled.

You can change name, description, conditions, and action configurations. You cannot change the trigger category.

### 3.14.4 Automation Templates

Templates are displayed as a carousel (or grid when expanded). Filter by category: All, Organization, Productivity, or Notifications.

Each template card shows the name, trigger type, and action service badges. Click **"Use Template"** to pre-fill the creation wizard with the template's settings. 20+ templates available.

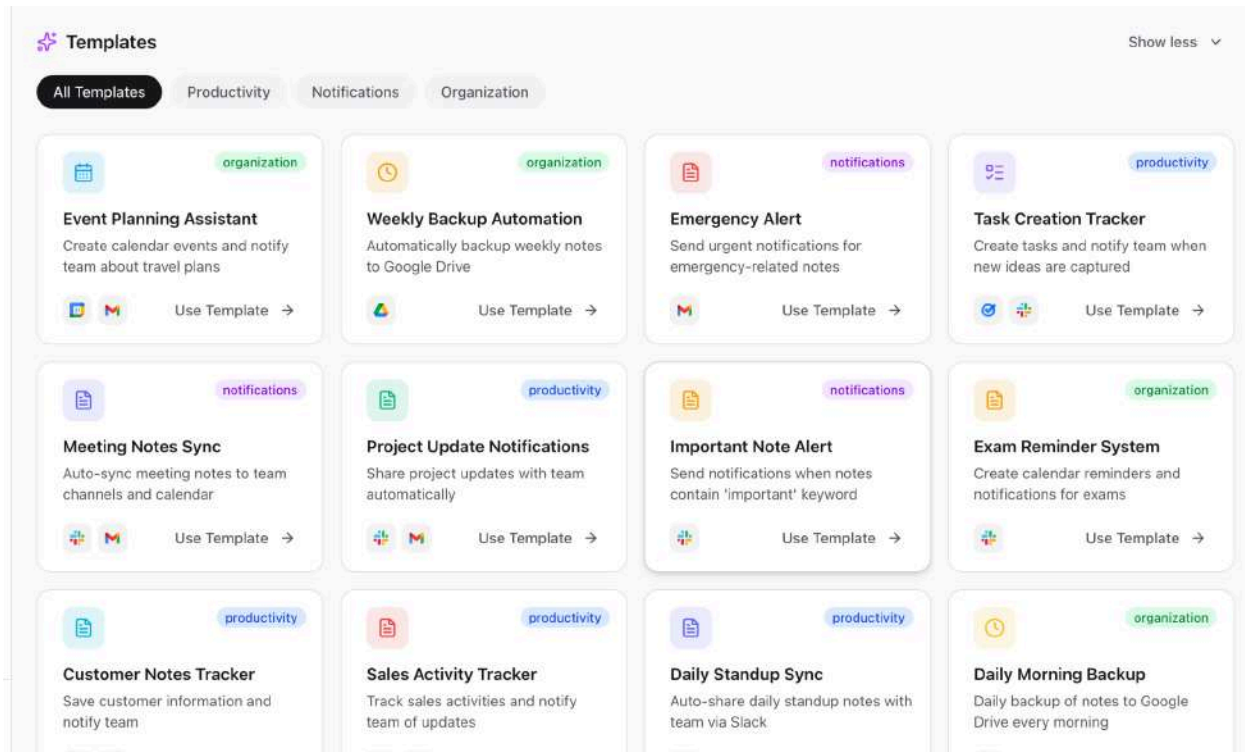

### 3.14.5 Connected Services (Google, Slack)

Click the "Services" button in the Automations header to manage connections.

Available services:

- Gmail : Send emails
- Google Drive : Create/update files
- Google Calendar : Create/update events
- Google Tasks : Create/update tasks
- Slack : Send messages to channels or DMs

Click "Connect" to authorize via OAuth. Click "Disconnect" to revoke if active automations depend on it, a warning lists the affected automations.

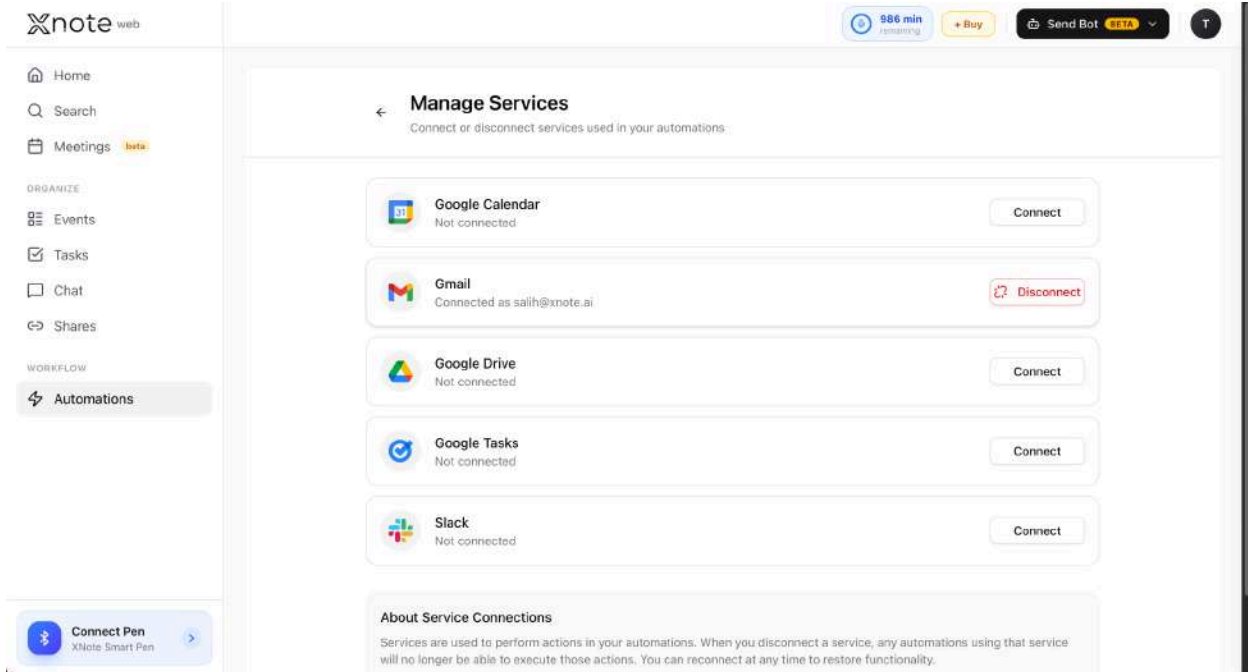

### 3.14.6 Automation History

Click the **"History"** button in the header to open the execution log panel.

Each entry shows:

- Automation name and trigger type
- Execution timestamp
- Action performed with service icon
- Status (success or failed with error message)

Filter by action type, trigger event, rule type, or sort order.

## 3.15 Folders & Tags

Folders and tags help you organize your pages across notebooks.

### 3.15.1 Create & Manage Folders

Create a Folder:

1. Click **"+ New Folder"** on the Home page (Folders tab) or All Folders page.

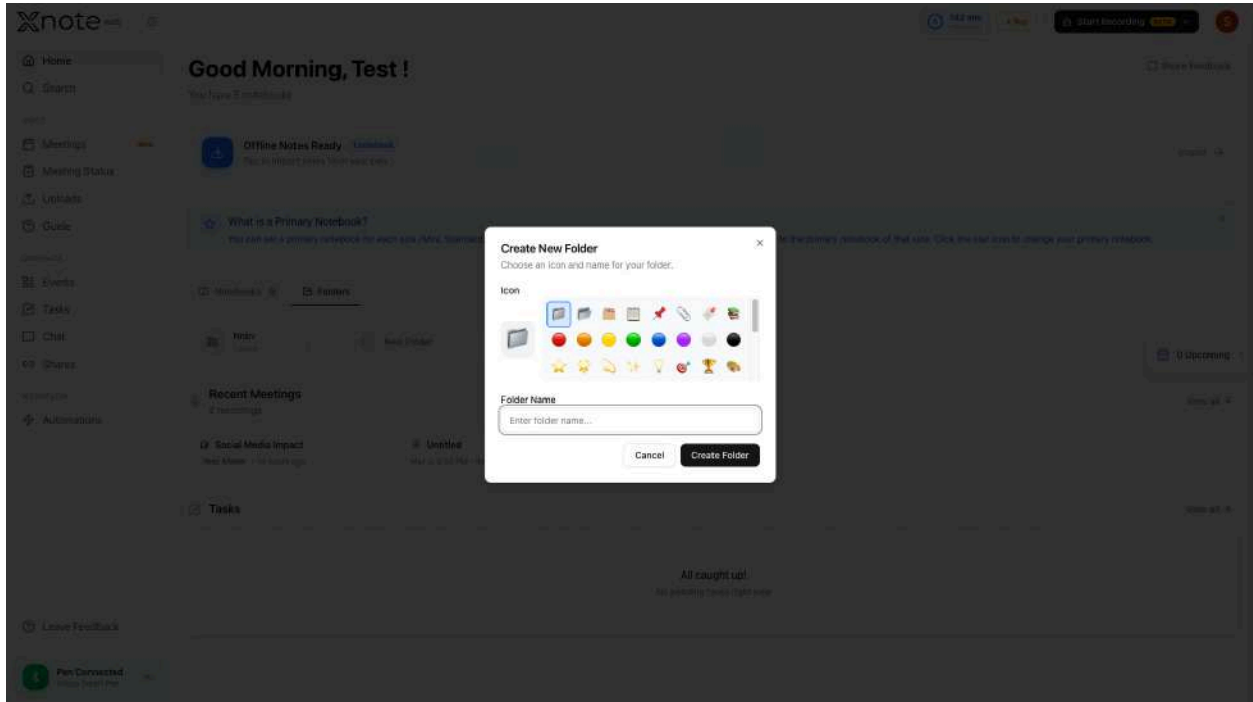

2. Enter a folder name and select an emoji in the dialog.

3. Click **"Create"**.

Rename or Change Emoji: Click the three-dot menu (or hover menu) on a folder card to open settings. Edit the name or emoji.

Delete a Folder: Click the delete option in the folder settings. Confirm in the dialog. Pages inside are not deleted.

### 3.15.2 View All Folders

Click "**View All**" in the Home Folders tab to open the All Folders page.

All your folders are displayed in a grid/flex layout. Each folder card shows:

- Folder emoji
- Folder name
- Page count

Click a folder to view its pages [\(see 3.15.3\)](#).

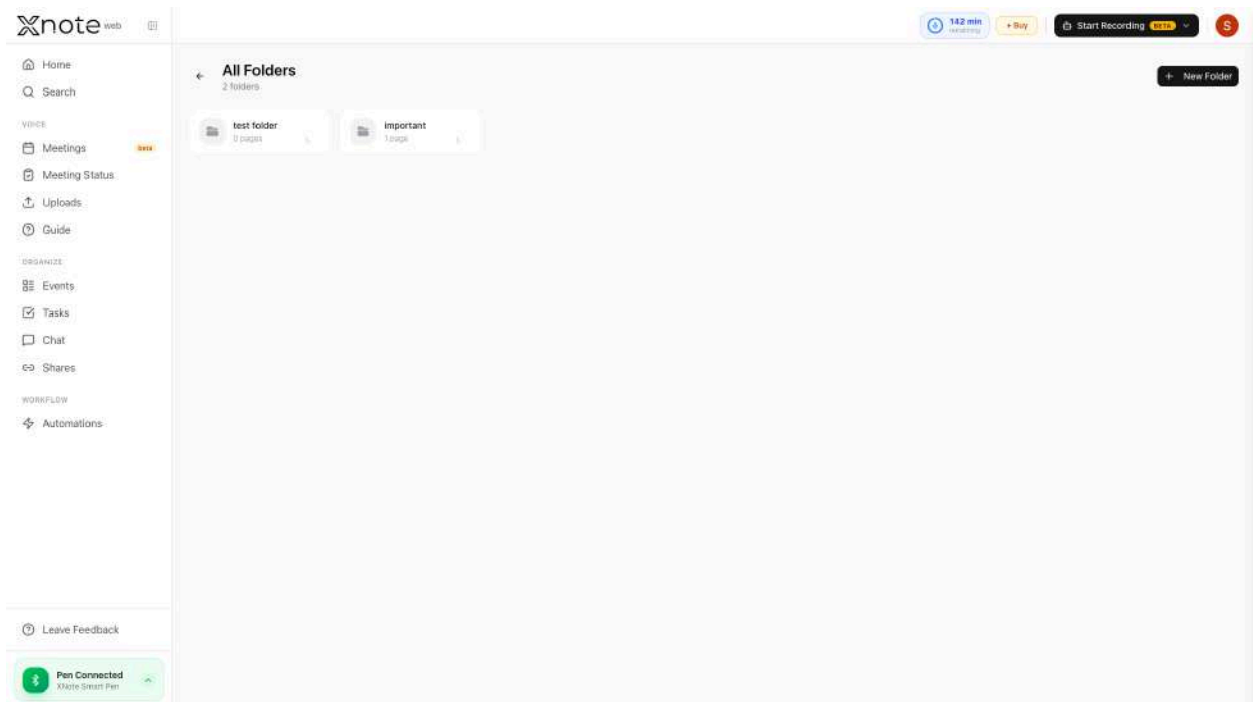

### 3.15.3 Folder Detail (View Pages in a Folder)

Click a folder to open the Folder Detail modal. Pages from different notebooks can appear in the same folder.

Each page shows:

- Page thumbnail
- Page number and notebook name
- Remove button (visible on hover)

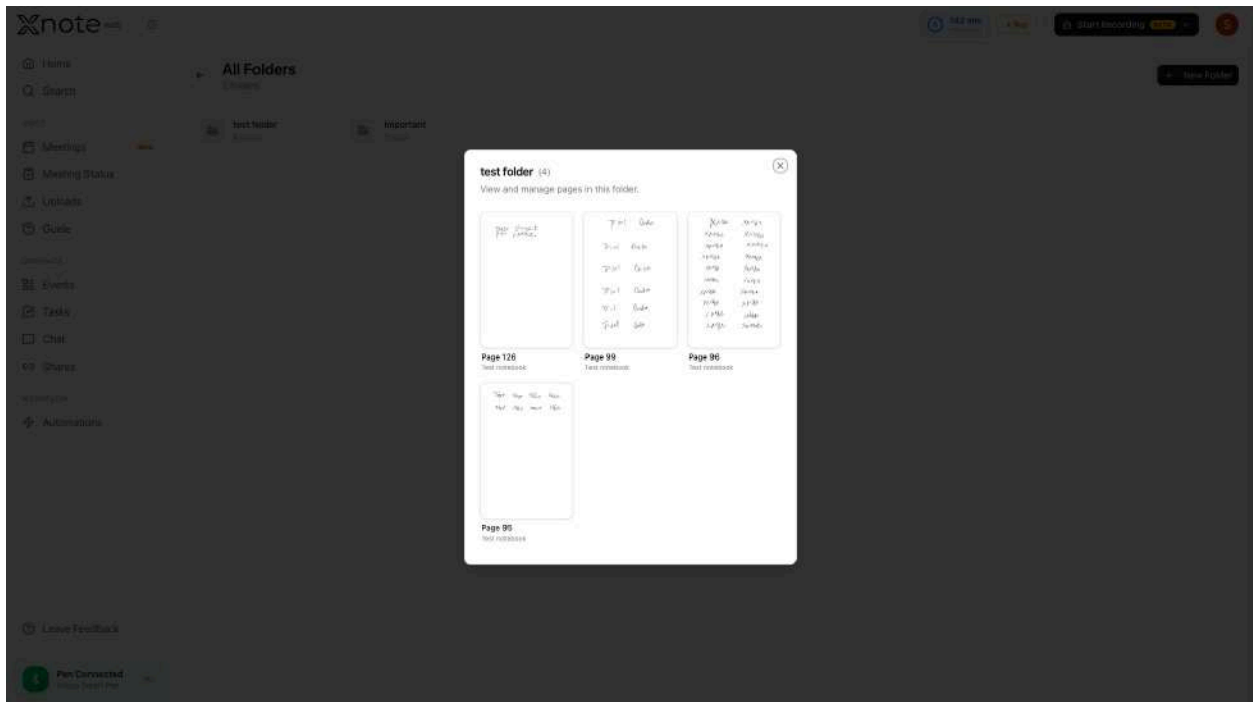

### 3.15.4 Add Pages to Folders

1. On the page detail toolbar, click the Folder icon.
2. Select a folder from the Add to Folder modal, or create a new one.
3. The page is added to the selected folder.

To remove a page from a folder, open the folder and click the remove option on the page.

### 3.15.5 Create & Manage Tags

Tags are managed from the Search page via the Tag Management dialog.

Create a Tag: Click **"Manage"** in the tags section. Enter a name (2-50 characters) and select a color from 12 presets. Click **"Create"**.

Edit a Tag: Click an existing tag in the management dialog. Modify the name or color and click **"Update"**.

Delete a Tag: Click the delete icon next to a tag and confirm.

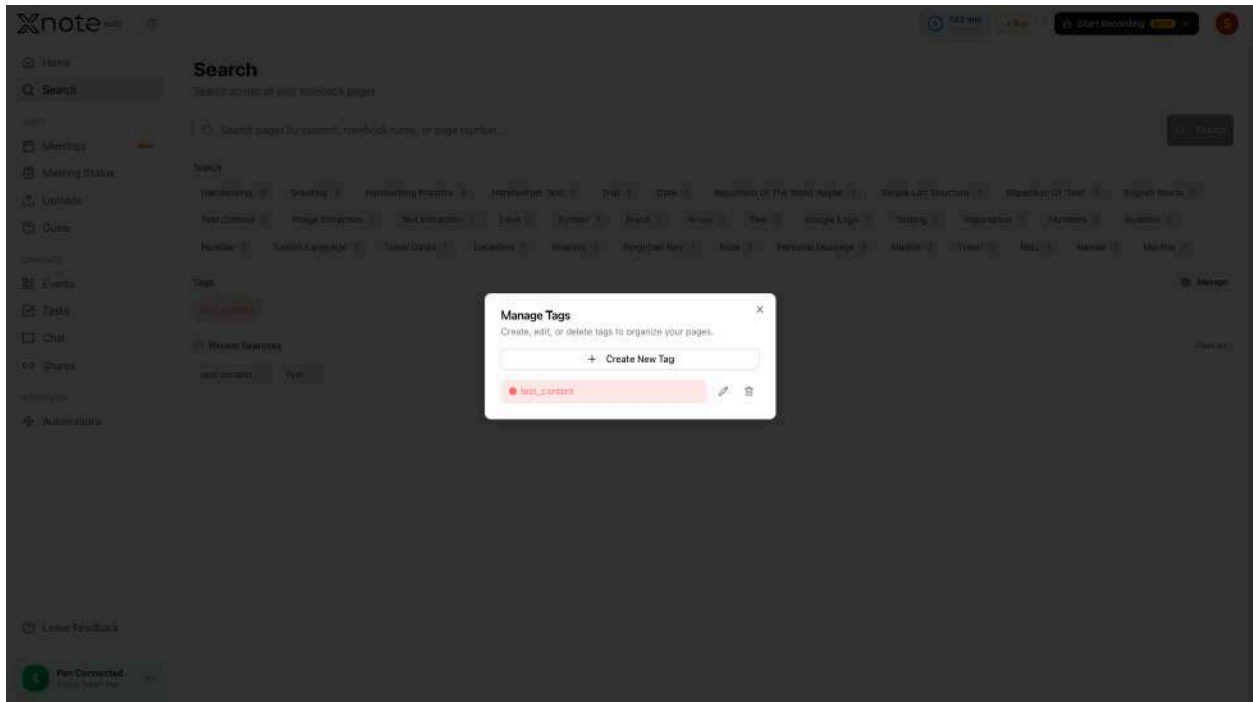

### 3.15.6 Tag Pages

1. On the page detail toolbar, click the Tags icon.
2. All your tags are displayed. Click a tag to apply it a checkmark appears.
3. Click again to remove the tag.

A page can have multiple tags. Tagged pages can be found through tag-based filtering on the Search page ([see 3.11.3](#)).

## 3.16 Share & Export

Share your pages and recordings via public links, or export pages in multiple formats.

### 3.16.1 Share a Page (Link)

1. On the page detail toolbar, click the Share icon.
2. Select an expiration: 7 days, 30 days, or Never.
3. Click **"Create Link"**.

Copy the link or use the share button to send it. Anyone with the link can view the page without logging in.

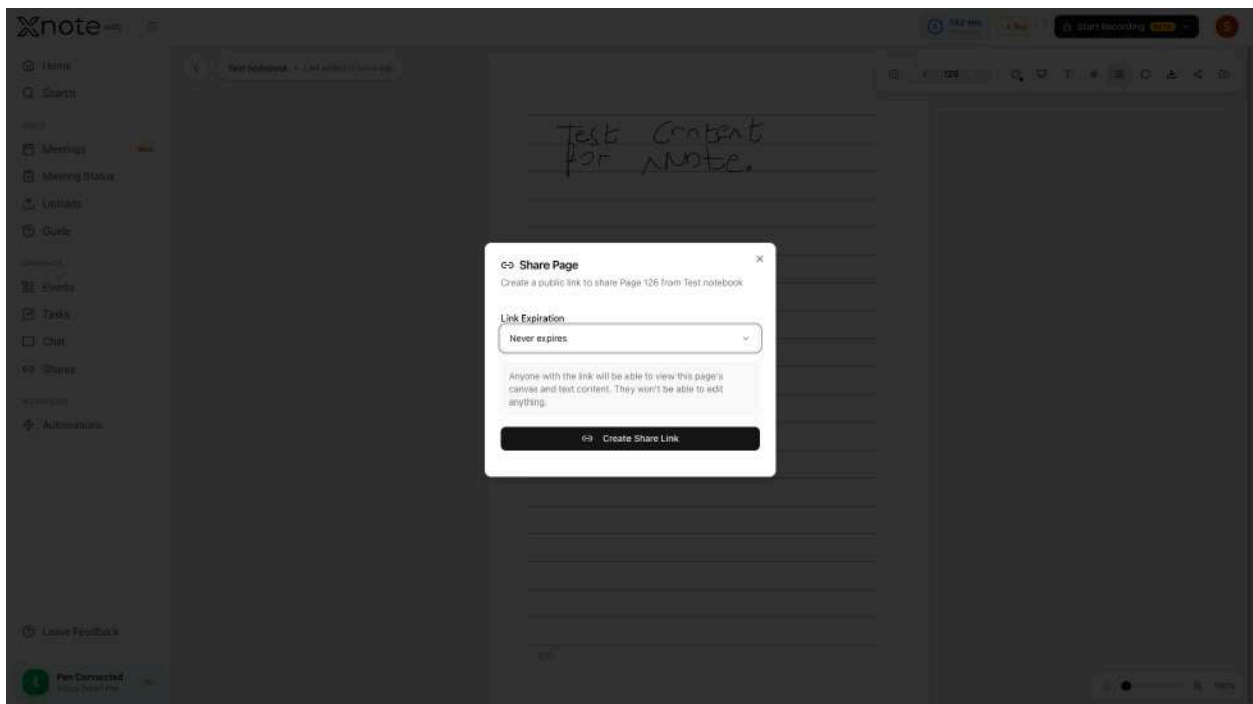

## 3.16.2 Share a Recording (Link)

1. Open an audio session and click Share.
2. Select an expiration: 7 days, 30 days, 1 year, or Never.
3. Choose email notification preference: Only Me, All Attendees, or None.
4. Click **"Create Link"**.

The shared link includes the AI-generated summary. The audio file remains private.

For recordings, a **"Shared Links"** dropdown shows all active shares with copy, open, and revoke options.

The screenshot displays the Xnote web application interface. A central dialog box titled "Share Recording" is open, showing a green "Link is active" status, a URL "https://web.xnote.ai/share/zntknP9tTUV", a "Copy Link" button, and a "Revoke Link" button. The background shows a meeting recording titled "Social Media Impact" with an AI Summary section containing key takeaways and a transcript on the right.

### 3.16.3 Manage Shares

XNote Web has a dedicated Shares page (accessible from the sidebar) showing all your shared links in one place.

The Shares page has tabs: All, Meetings, and Pages. Each share shows:

- Title and type
- Provider badge (for recordings)
- Creation date and expiration date
- Copy link, open link, and revoke buttons

To revoke a share, click the revoke button and confirm. The link is immediately disabled.

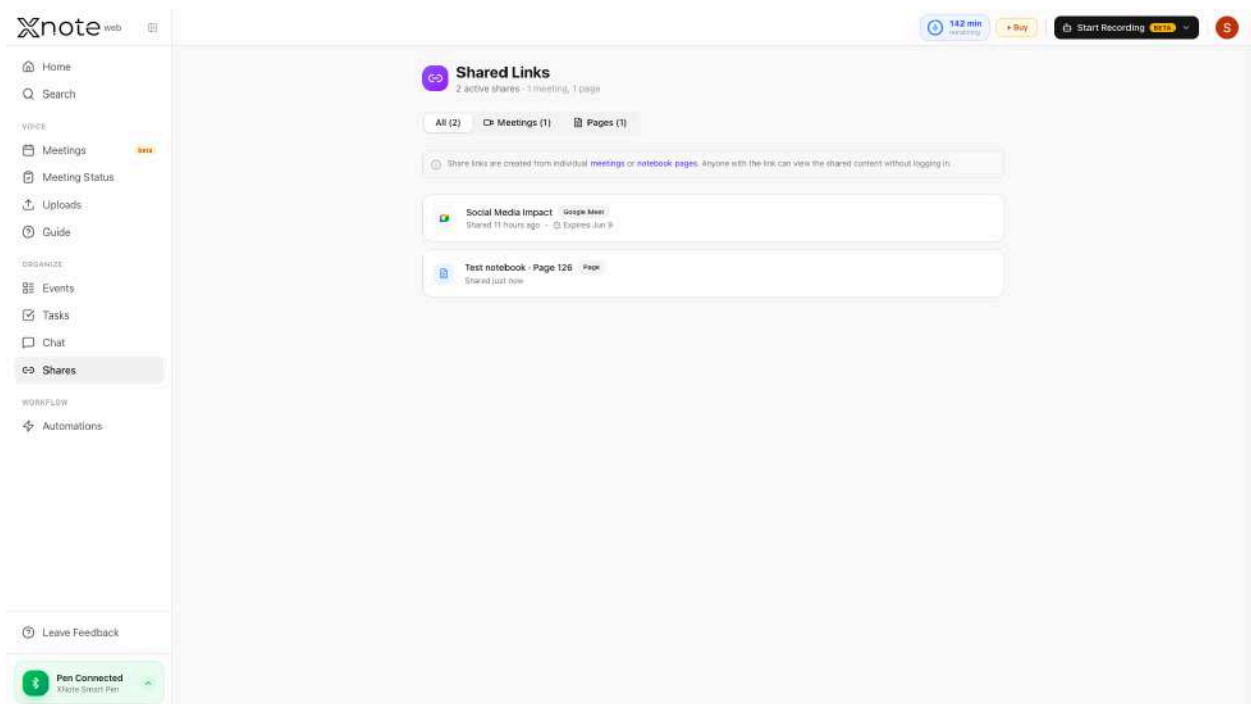

### 3.16.4 Export Pages (PDF, PNG, SVG, DOCX, Markdown)

On the page detail toolbar, click the Export icon for a quick export dropdown.

Quick Export: One-click export of the current page as Handwriting PDF or Digital Text DOCX. You can toggle whether to include the notebook title and page number in the header.

Advanced Export: Select specific pages and choose a format:

Handwriting formats:

- PDF : Handwriting (strokes)
- PNG : Handwriting as image
- SVG : Handwriting as scalable vector

Digital Text formats:

- PDF : Text-only PDF
- DOCX : Word document
- Markdown : Plain text markdown

Toggle "Show notebook background" on or off for handwriting exports.

Note: Unlike the mobile app, exporting an entire notebook as a single PDF is done from the notebook settings dialog (click the three-dot menu on a notebook card → "Share Notebook").

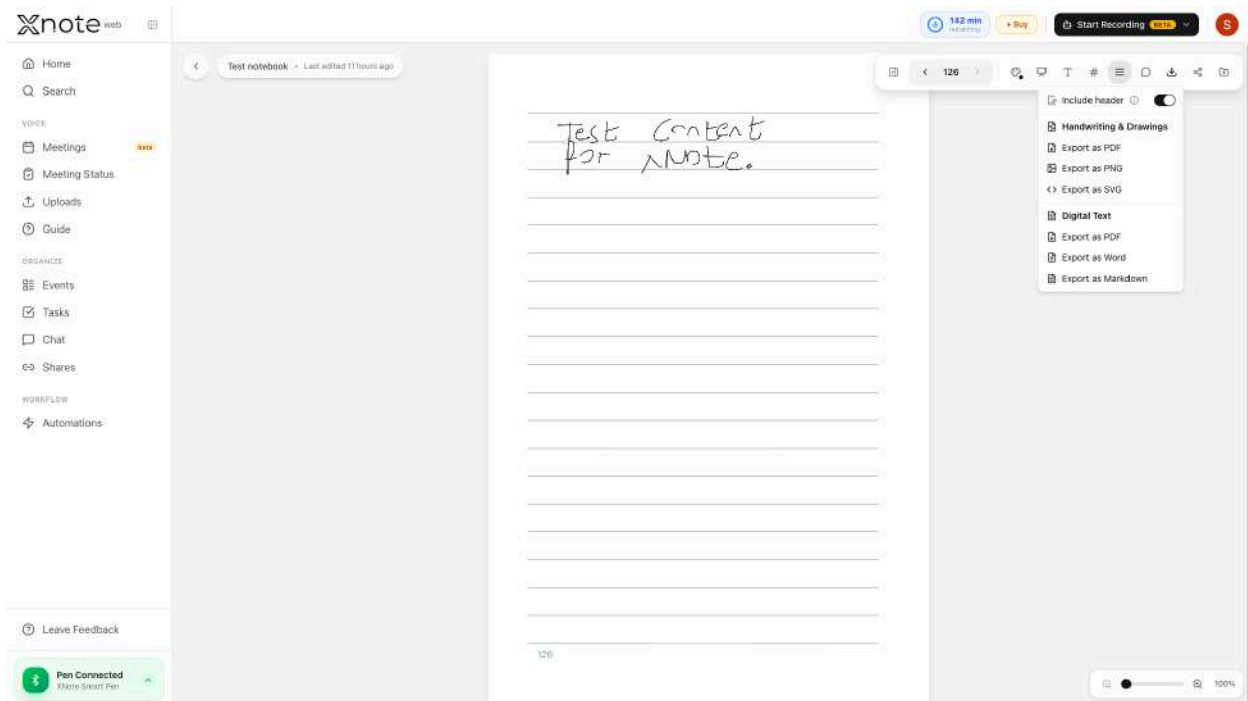

### 3.16.5 Bulk Export (Multiple Pages)

1. On the notebook pages grid, click **"Export Pages"** to enter selection mode.
2. A selection banner appears with **"Select All"** / **"Deselect All"** toggle.
3. Check the pages you want.
4. Click **"Export"** in the floating action bar at the bottom.
5. Choose a format.

Multi-file exports (PNG, SVG) are packaged as a ZIP archive. Text-based exports (DOCX, Markdown) combine all pages into a single document.

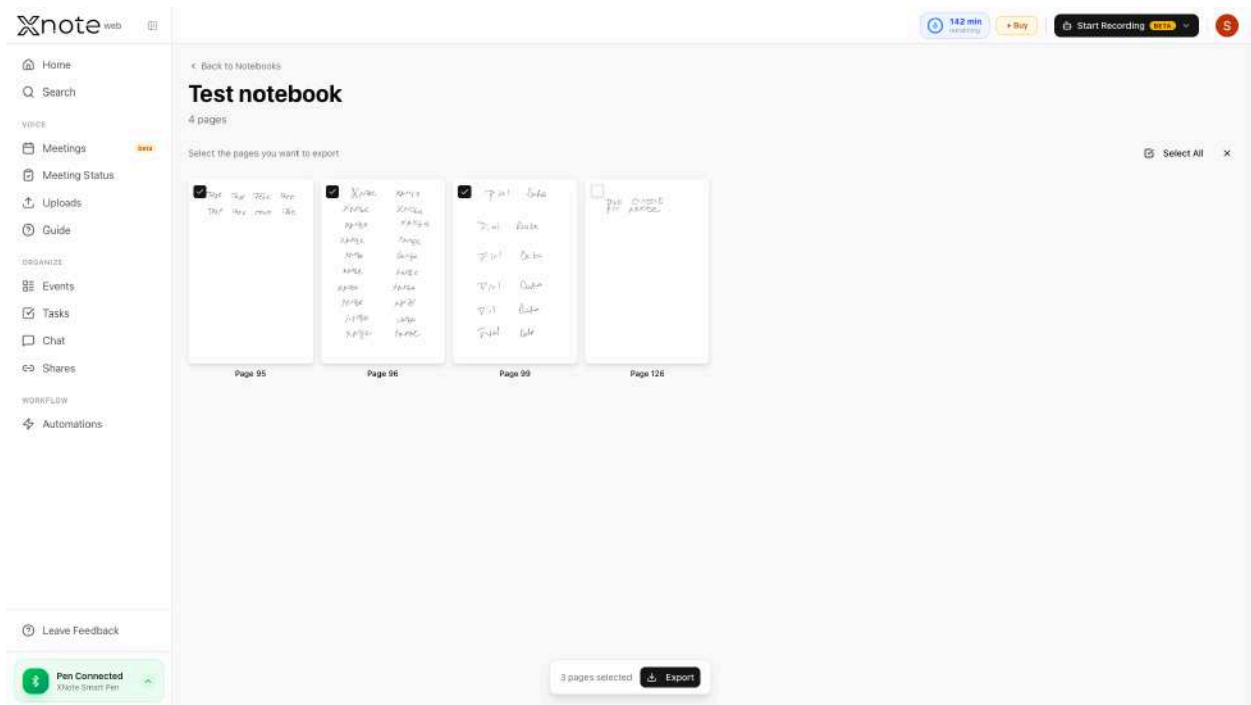

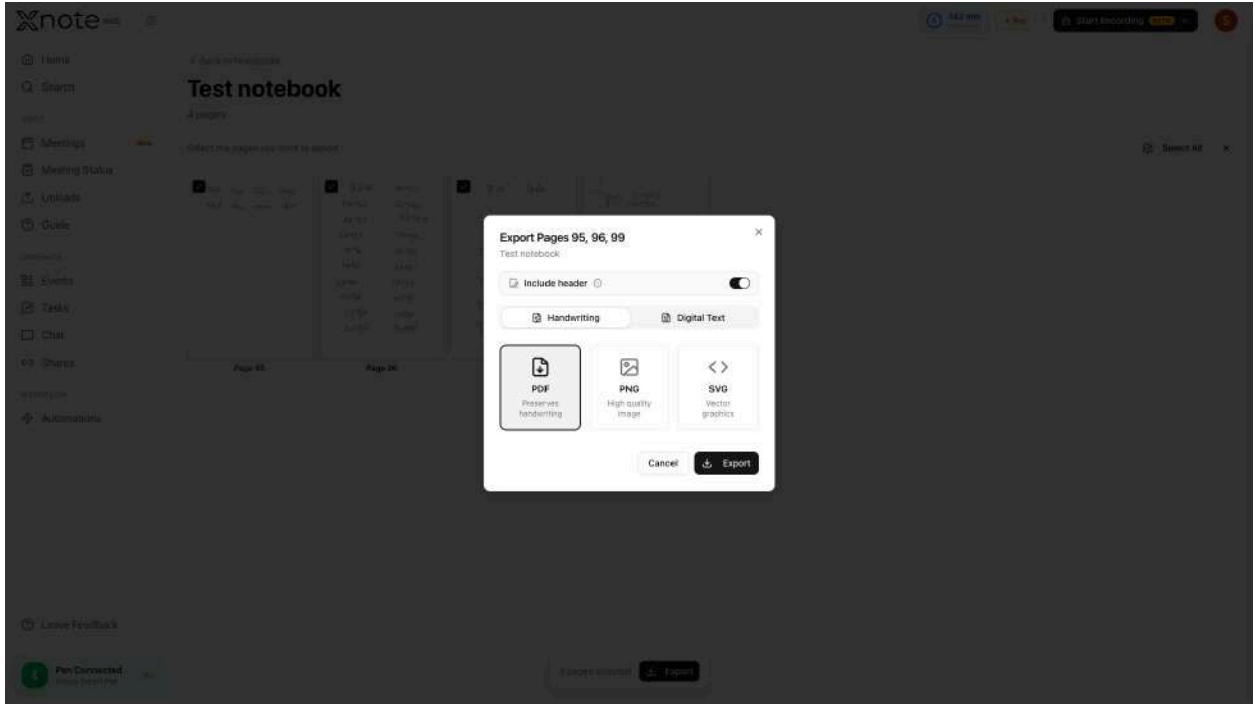

## 3.17 Offline Sync

Sync handwritten notes from your XNote Pen to XNote Web via Web Bluetooth (Chrome, Edge, or Opera required).

### 3.17.1 Home Screen Sync Banner

When unsynced data exists on your pen, a blue gradient banner with a pulse animation appears on the Home page showing the count of offline notebooks ready to import. Click the banner to open the Offline Sync page.

The screenshot displays the XNote Web interface. At the top, there's a navigation bar with the XNote logo, a search bar, and utility buttons like '142 min', '+ Buy', 'Start Recording', and a profile icon. The main content area is titled 'Good Morning, Test!' and shows 'You have 5 notebooks'. A prominent blue gradient banner with a pulse animation reads 'Offline Notes Ready' and 'Tap to import notes from your pen'. Below this is a help box titled 'What is a Primary Notebook?'. The 'Notebooks' section shows five notebooks: 'Notebook - 4' (Large, 5/192 pages, Primary), 'Test notebook' (Mini, 4/144 pages, Primary), 'Notebook - 2' (Standard, 0/192 pages, Primary), 'Notebook - 3' (Mini, 20/144 pages), and 'main notebook' (Mini, 14/144 pages). There are also buttons for 'New Notebook' and 'View All Notebooks'. The 'Recent Meetings' section shows two recordings: 'Social Media Impact' and 'Untitled'. The 'Tasks' section is currently empty. A 'Pen Connected' indicator is visible at the bottom left, and a status message at the bottom center says 'All caught up! No pending tasks right now.'

### 3.17.2 Sync from Pen

The Offline Sync page shows notebooks on the pen that have unsynced pages. Each notebook card displays the notebook type badge and page count.

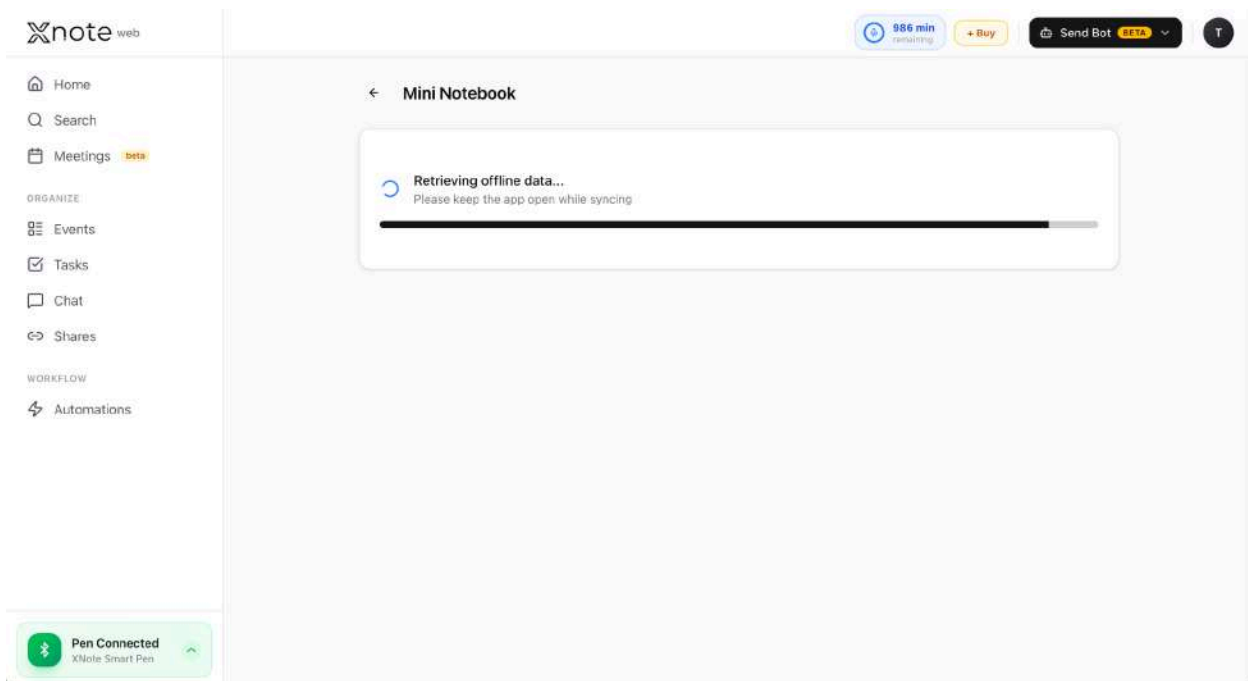
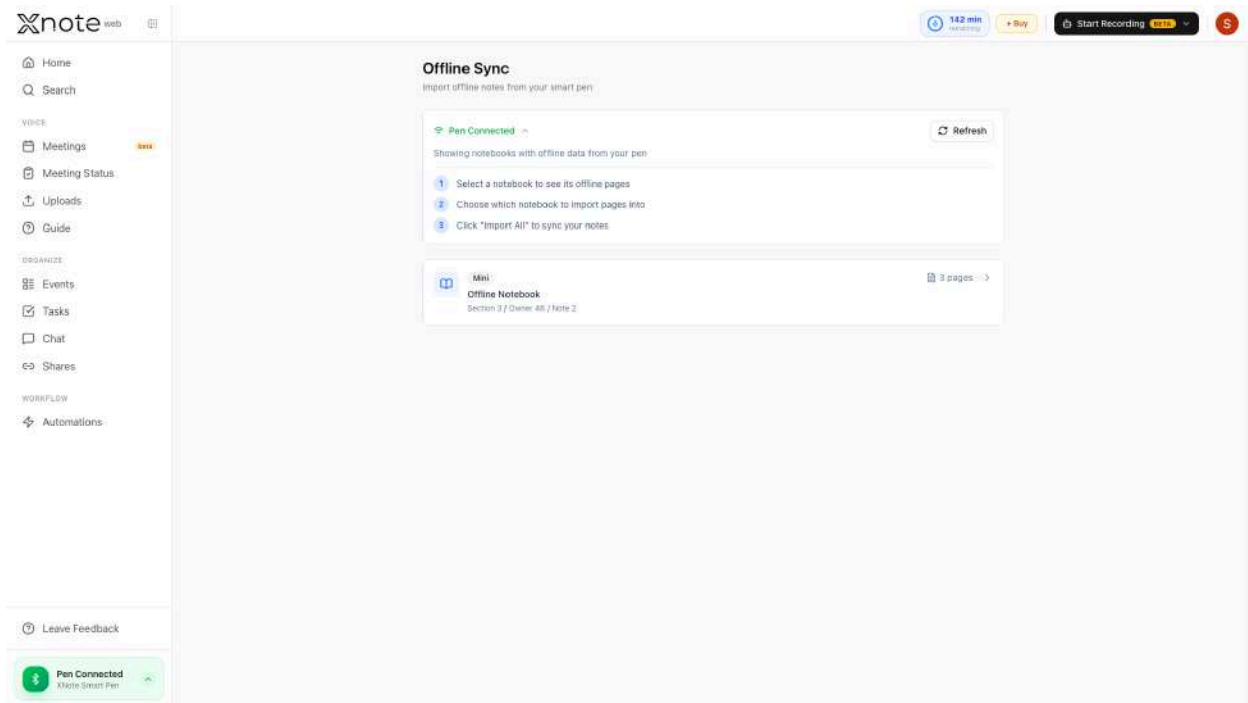

1. Make sure your pen is connected via Bluetooth.

2. Select the pages you want to save and choose a target notebook. Your primary notebook of the matching size is auto-selected.

3. Click **"Save All"** to sync.

If the pen is not connected, the page redirects you to connect first.

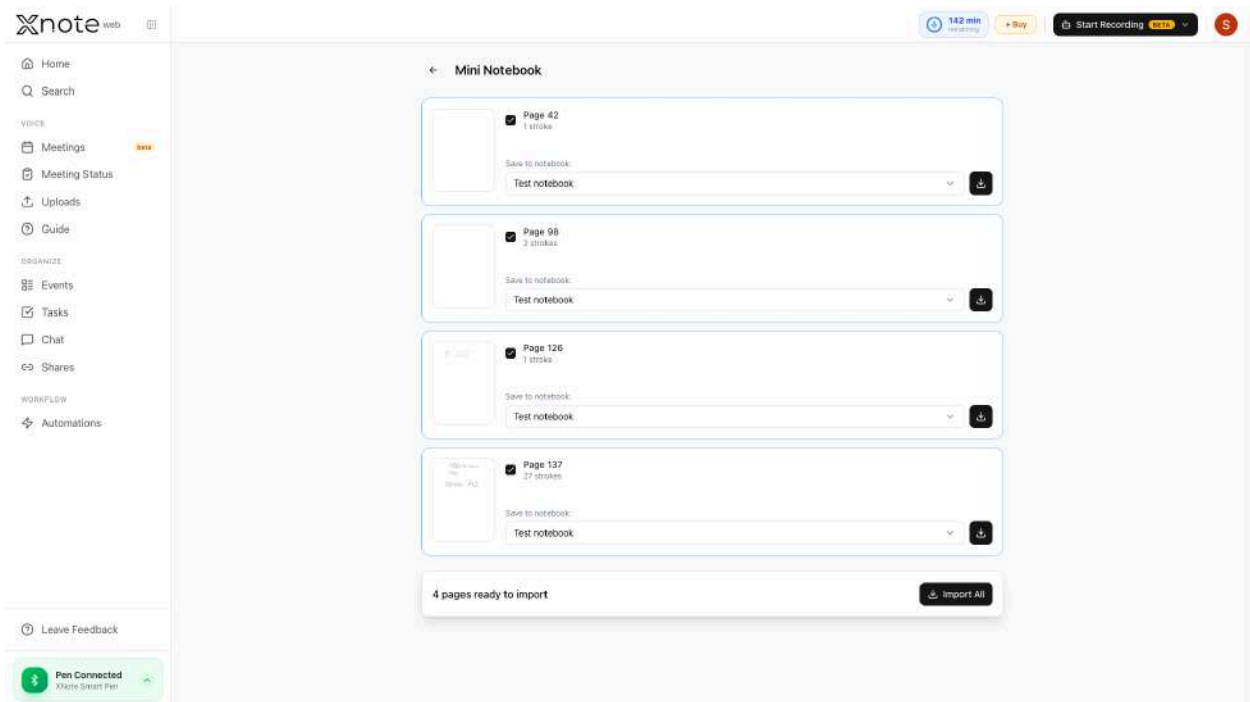

### 3.17.3 Sync Progress & Results

During sync, a progress bar shows the save progress per page with a **"Saving..."** indicator.

The Home page shows a blue sync banner when offline notebooks are pending import, displaying the count of notebooks ready to sync.

Real-time sync status with the server is managed automatically changes are uploaded and downloaded in the background via PowerSync.

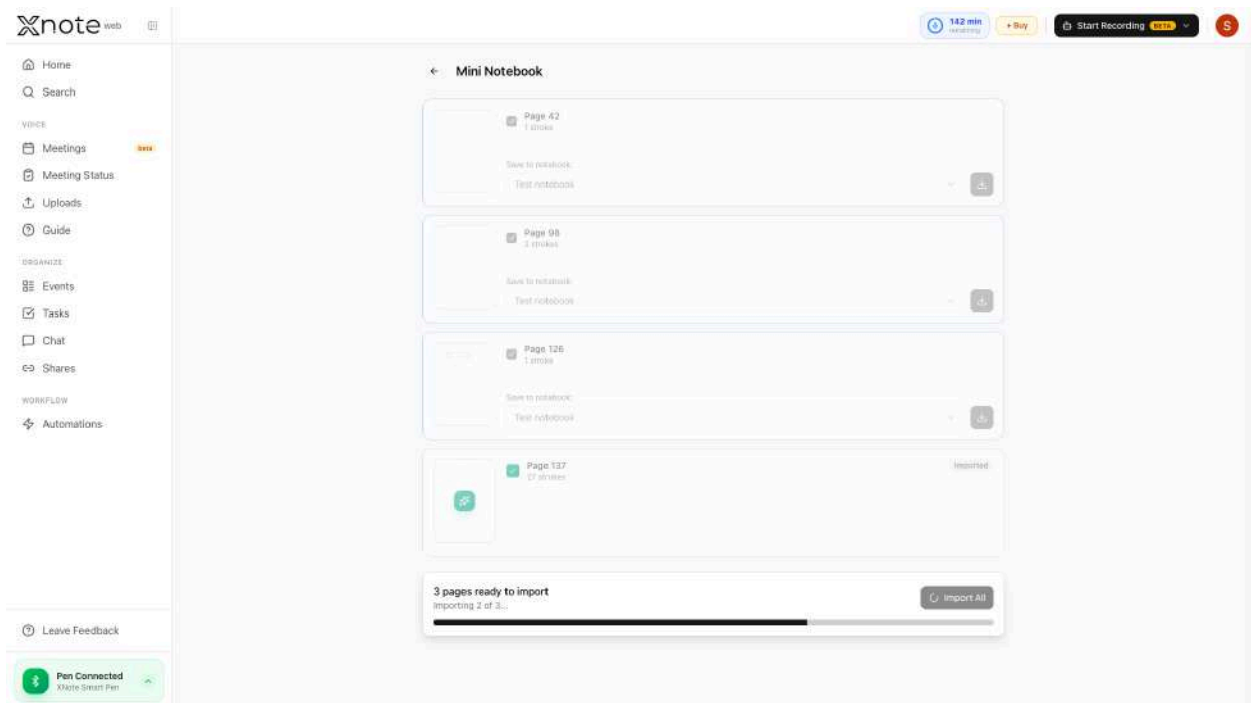

## 3.18 Settings

Click your profile avatar in the top-right corner to open the account menu. It shows:

- A Mobile App card with App Store and Google Play links.
- Your name, email, and current plan (Free, Pro, Unlimited, or Lifetime).
- Audio Minutes remaining (e.g. "142 min left / 150 min", or Unlimited) and your Workflows usage (e.g. "0 / 5" or "0 / Unlimited"), each with a progress bar. Free users also see an Upgrade button.
- A Language selector to change the app's display language.
- Settings, Subscription, and Logout.

Click Settings to open the Settings page, which uses a responsive two-column layout on desktop.

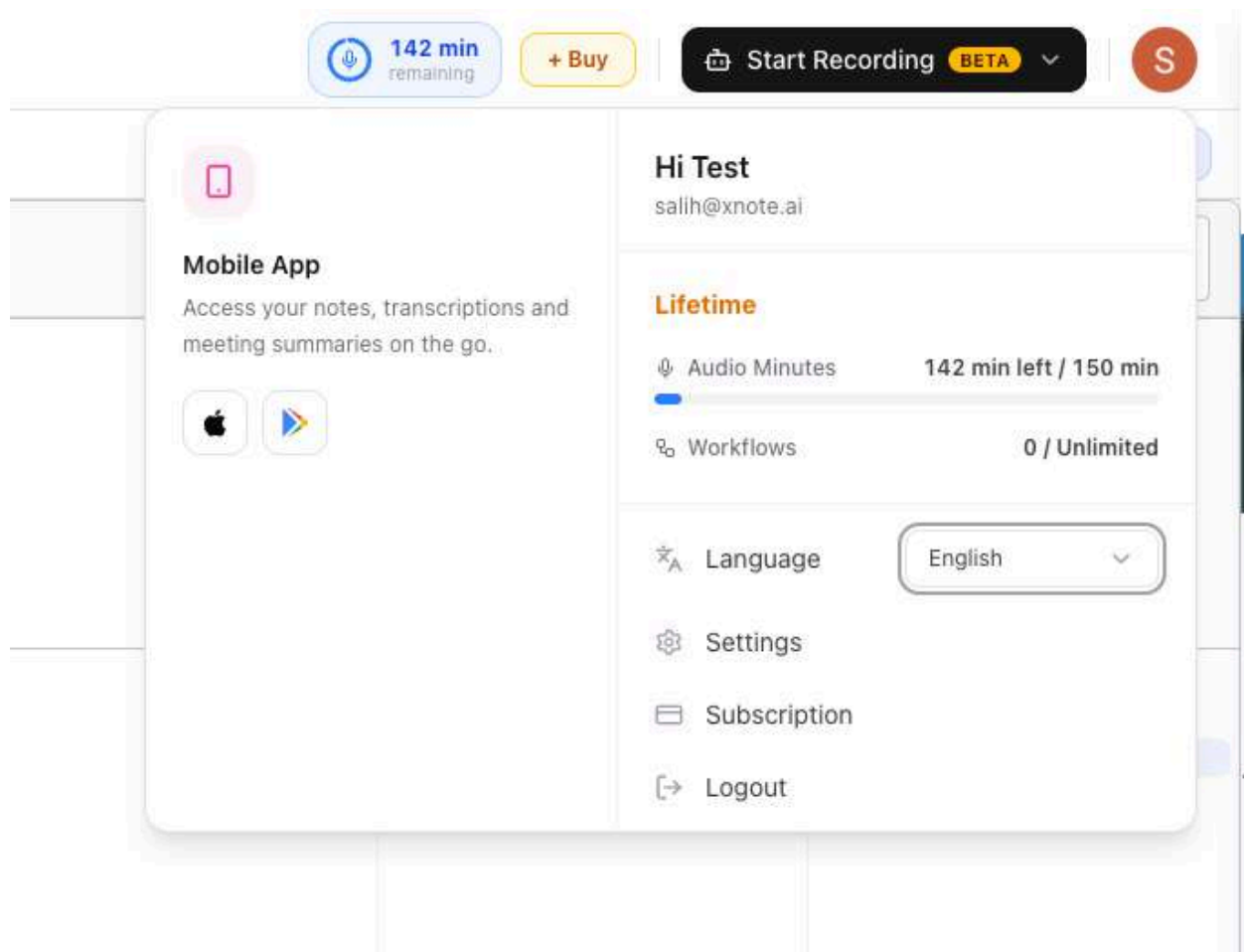

### 3.18.1 Profile

Go to Settings -> Profile to view and edit:

- Name : Click to change your display name.
- Email : Shown with your login method (Email, Google, or Apple).
- Avatar : Profile photo or initials.
- Member since and last login dates.

## Profile

Update your personal information



**Test** [Email login](#)

✉ test@xnote.ai

📅 Member since March 24, 2026

🕒 Last login March 25, 2026 at 07:05 AM

---

**First name**

**Last name**

 Save changes

### 3.18.2 Email & Notifications

Change Email (email/password accounts only):

1. Go to Settings -> Change Email.
2. Verify your current email with a 6-digit OTP code.
3. Enter your new email and verify it with another OTP code.

#### Email Address

Change your email address. Verification codes will be sent to both emails.

 **test@xnote.ai**  
Primary email address

**1** Enter your new email address

#### New email address

 Verification codes will be sent to both your current email (test@xnote.ai) and your new email. You must verify both to complete the change.

 **Send verification codes**

### 3.18.3 Password & Security

Go to Settings -> Change Password.

Enter your current password and set a new one. If you signed up with Google or Apple, you can add a password for email/password login.

Password requirements: 8+ characters, uppercase, lowercase, number, and special character.

## Security

Update your password to keep your account secure

**Current password**

**New password**

**Confirm new password**

 **Update password**

### 3.18.4 Connected Accounts

Link or unlink your Google and Apple accounts. This allows you to sign in with multiple methods.

- Click "**Link Google Account**" or "**Link Apple Account**" to connect an additional sign-in method.

- Click "**Unlink**" to remove a connected account (you must have at least one sign-in method active).

Note: This is a web-specific feature. On mobile, connected accounts are managed through the sign-in flow, not as a separate settings section.

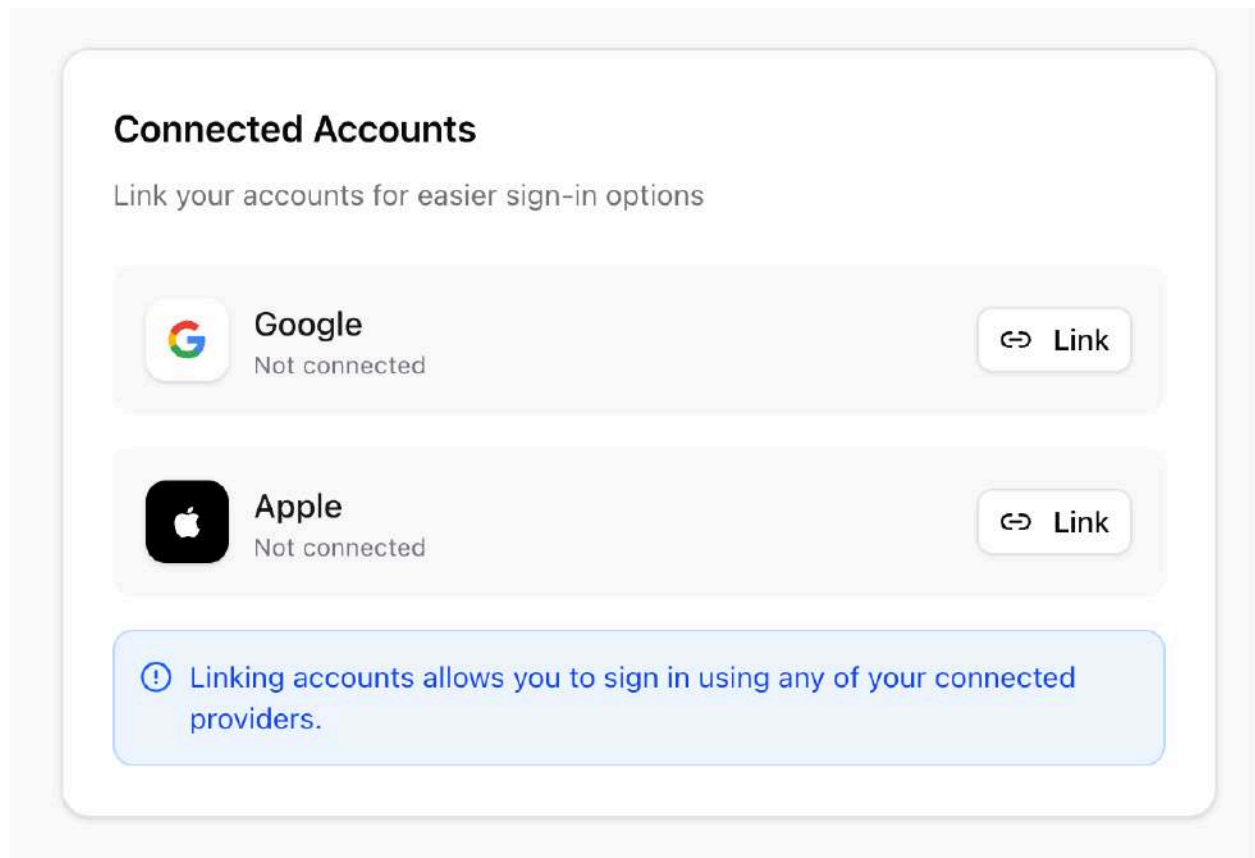

### 3.18.5 Pen & Notebooks

- Pen Settings : Visible only when pen is connected. For full details, [see 3.8.1](#).
- Primary Notebooks : Assign a primary notebook for each size using dropdown selectors. See 3.5 for full details.

Note: Unlike the mobile app, Deleted Notebooks recovery is not available on web.

### 3.18.6 Integrations

- **Todoist** : Connect your Todoist account to sync tasks. For setup details, [see 3.12.4](#).
- **Zapier** : Connect XNote with 5,000+ apps via Zapier to automate your workflows. Unlike other integrations, Zapier uses an API key (not OAuth).

Creating your Zapier Key on XNote Web:

1. Go to Settings → Zapier.
2. Click "Create Zapier Key". A unique API key will be generated for your account.
3. Copy the key (displayed in masked format with a copy button).

To regenerate your key: Click "Regenerate" in the Zapier settings. A confirmation dialog warns that this will invalidate the current key — any existing Zapier automations using the old key will stop working until you update them with the new key.

#### What's next?

After generating your key, you need to set up your automation on the Zapier platform. This includes selecting XNote as a trigger app, pasting your API key, choosing trigger events (such as Task Created, Note Updated, etc.), and configuring actions. The full step-by-step Zapier platform setup is described in Section [2.17.5](#) under "Setting Up Your Zap on Zapier".

## Integrations

Connect XNote with your favorite apps



**Todoist**

Not connected

↔ **Connect**

ⓘ Connect your Todoist account to sync tasks from XNote. Your tasks will be sent to your Todoist inbox with customizable labels and priorities.



**Zapier Integration**

No API Key

🔑 **Create Key**

🔗 How to Connect



ⓘ Connect XNote to Zapier to automate your workflows. Trigger actions in other apps when you create tasks, complete tasks, or update notes.

### 3.18.7 Support & Resources

- User Guide : Opens the XNote support site
- Bug Report & Feedback : Opens a feedback form
- Additional Resources : App version, privacy policy, terms of service

### 3.18.8 Account Deletion

Go to Settings -> Danger Zone -> Delete Account.

1. Click "**Delete Account**".
2. Confirm in the first dialog.
3. Confirm in the second dialog: "**Your account and all data will be deleted permanently.**"

Account deletion is scheduled with a 14-day grace period. If you sign back in within 14 days, your account will be restored. After 14 days, deletion is irreversible.

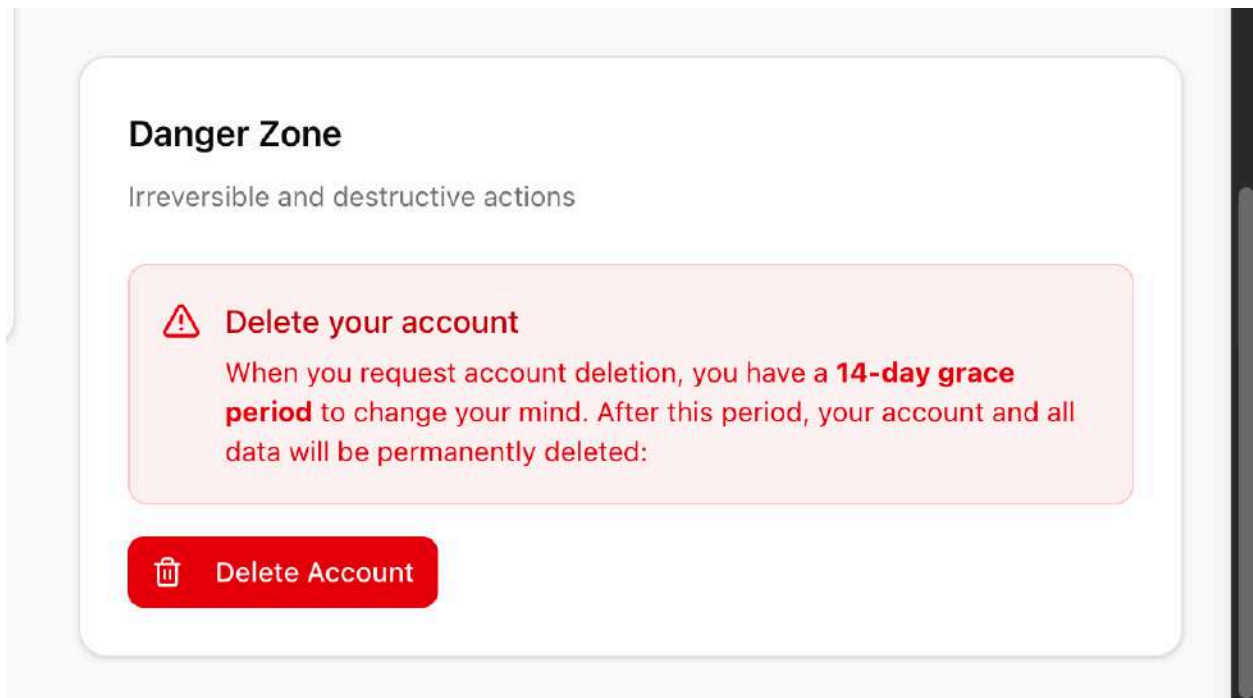

### 3.18.9 Sign Out

Click "Logout" in the Settings menu on header. You will be returned to the landing page.

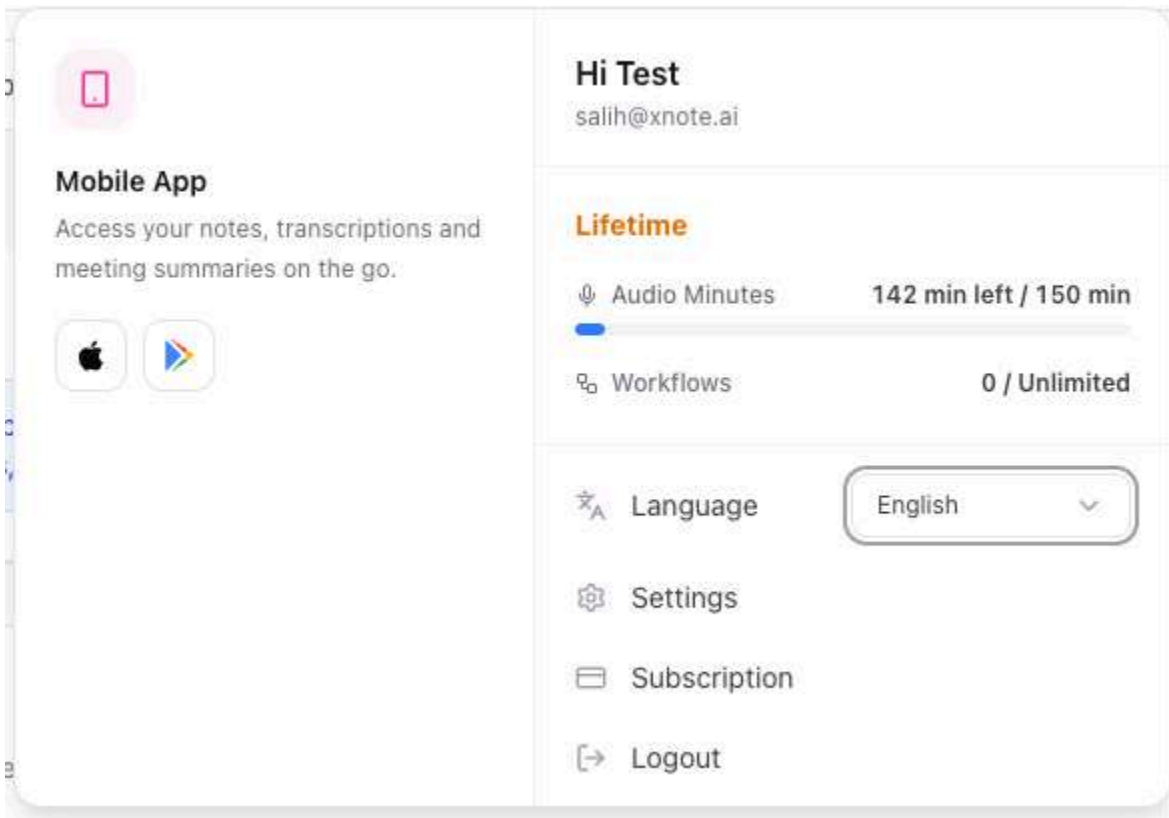

## 3.19 Subscription

Manage your subscription from right header pop-up menu.

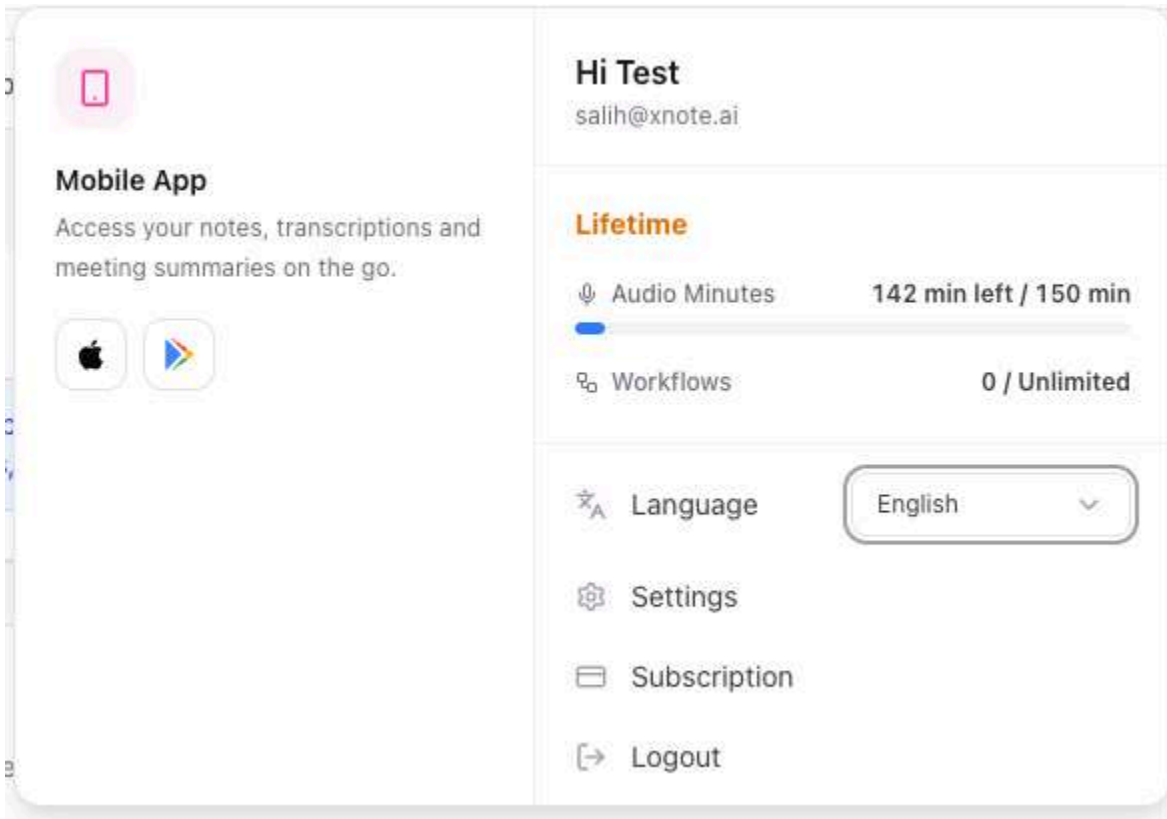

### 3.19.1 View Current Plan

The subscription page shows your current plan:

- Plan name (Free, Pro, Unlimited, or Lifetime) with a status badge
- Audio minutes usage with progress bar and bonus minutes badge
- Workflow limit count
- Quota reset date (for free plans)

Available plans:

- Free : 150 audio minutes/month. No workflows.
- Pro : 500 audio minutes/month. Limited number of active workflows.
- Unlimited : Unlimited audio minutes. Unlimited workflows.
- Lifetime : Unlimited audio minutes. Unlimited workflows. One-time purchase.

Note: On XNote Web, there is no in-app paywall or "Buy More Minutes" feature. To upgrade or purchase add-on minutes, use the mobile app or visit [xnote.ai](https://xnote.ai).

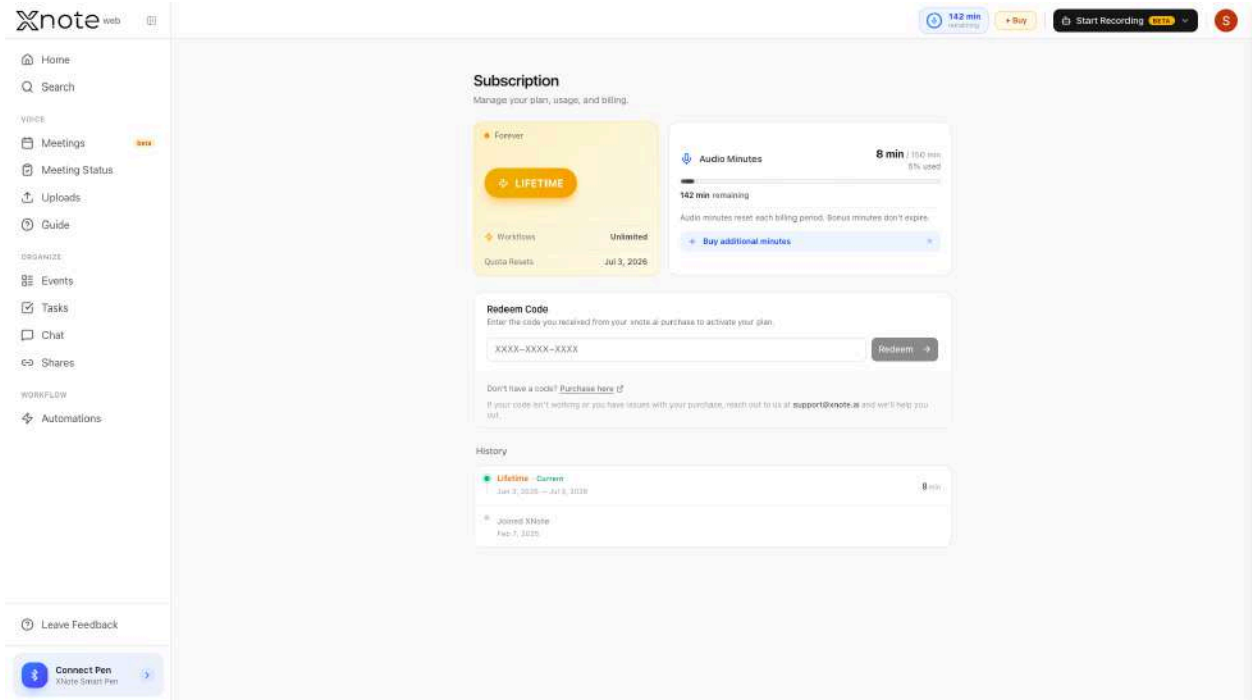

### 3.19.2 Usage Tracking (Audio Minutes, Workflows)

Audio Minutes: A progress bar shows used vs. total minutes. When minutes are exhausted, a red warning banner appears.

Workflows: Shows active workflow count vs. your plan limit.

### 3.19.3 Redeem Code

1. Go to Settings -> Subscription -> Redeem Code.
2. Enter your code (from the XNote web store or promotional campaigns).
3. Click "**Redeem**".

Codes can activate a plan (Pro, Unlimited, or Lifetime) for a specific duration, or add audio minutes to your account.

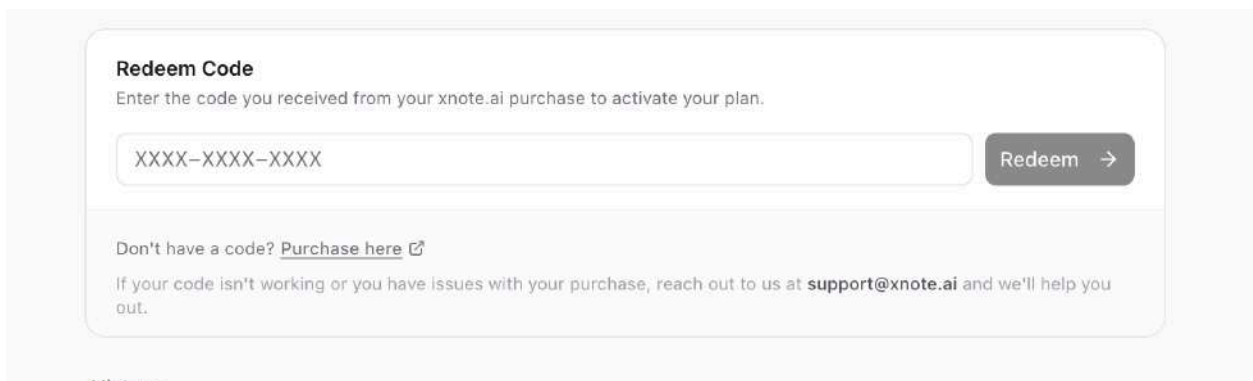

### 3.19.4 Subscription Timeline

Below the plan card, a timeline shows your full subscription history:

- Subscription events : Activations, renewals, upgrades, downgrades, cancellations
- Add-on events : Minute purchases and redemptions
- Joined event : Account creation date

Each entry is color-coded with a status badge. Click **"Show All"** to expand the full history.

Note: On XNote Web, subscription upgrades are managed through the Redeem Code feature or your existing subscription provider (App Store / Google Play account). There is no in-app paywall on web this is a mobile-only feature.

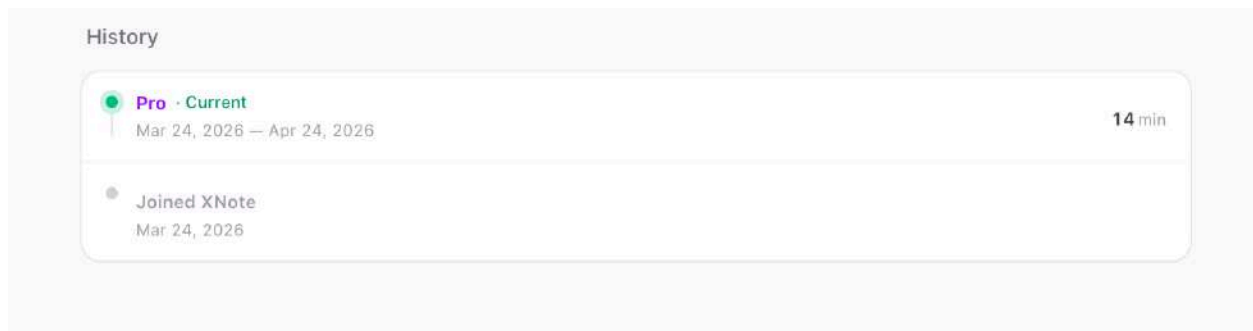

## 4. Subscription

### 4.1 Plans Overview

XNote offers four plans. All plans include handwriting recognition (OCR), AI Chat, flashcards, summaries, translation, chart generation, search, and integrations (Todoist, Google Calendar).

	Free	Pro	Unlimited	Lifetime
Price	\$0	\$14.99/mo or \$99/yr	\$249/yr	One-time purchase
Monthly Audio Minutes	150	1,000	3,000	150
Active Workflows	None	Up to 5	Unlimited	Unlimited
Add-on Minutes	Available	Available	Available	Available

All prices shown are in USD. Regional pricing may vary depending on your App Store or Google Play region.

Notes:

- The Lifetime plan is a legacy plan and is no longer available for new users.
- When a paid subscription ends, the user falls back to their base plan.
- Premium features (workflows, etc.) are available to Pro, Unlimited, and Lifetime users.

## 4.2 Audio Minutes

All audio processing features transcription, Meeting Bot, and AI-generated summaries consume audio minutes from your monthly quota.

Usage Priority:

1. Monthly subscription minutes are used first.
2. Add-on minutes are used only after monthly minutes are exhausted.

Monthly Reset: Subscription minutes reset automatically every month, including for yearly plans.

Quota Warnings:

- Orange warning when usage exceeds 50%.
- Red warning when usage exceeds 80%.
- When fully exhausted, you will be prompted to purchase more minutes or upgrade your plan.
- If a recording exceeds your remaining quota, you can choose partial transcription or purchase more minutes.

## 4.3 Add-on Audio Minutes

Add-on minutes never expire and are available for purchase on all plans.

Package	Minutes	Price	Per inute
Lite	200	\$4.00	\$0.020
Standard	600	\$10.00	\$0.017
Bulk	1,500	\$20.00	\$0.013

## 4.4 Purchase Channels

Channel	Description
App Store (iOS)	In-app purchase on iPhone/iPad via App Store. Plan is activated immediately after purchase.
Google Play (Android)	In-app purchase on Android via Play Store. Plan is activated immediately after purchase.
Redeem Code	Codes from the XNote web store (xnote.ai) or promotional campaigns. Requires manual activation — you must enter the code in the app or web to activate your purchase (see <a href="#">4.6</a> ).

Pricing is displayed in your local currency as determined by the App Store or Google Play. Prices listed in this guide are in USD and may vary by region due to local taxes, currency conversion, and store pricing policies. XNote does not handle payment information directly.

**Important:** Purchases made through the App Store or Google Play are activated automatically. **However, purchases made on xnote.ai (subscription plans or add-on audio minutes) are delivered as a redeem code via email. These are not activated automatically — you must enter the code in the XNote app or web to activate your plan or minutes.** See Section [4.6](#) for instructions.

## 4.5 Upgrade & Downgrade

- Free → Pro or Unlimited: Full paywall with plan comparison and pricing.
- Pro → Unlimited: Dedicated upgrade paywall showing only the Unlimited plan.
- Cancellation: Access continues until the end of the current billing period, then the user falls back to their base plan .

## 4.6 Redeem Code

When you purchase a subscription plan or add-on audio minutes from xnote.ai, you will receive a redeem code via email. This code must be entered manually to activate your purchase on your XNote account.

How to redeem:

- Mobile: Go to Settings → Subscription → Redeem Code (see [2.18.5](#)).
- Web: Go to Subscription → Redeem Code (see [3.19.3](#)).

Steps:

1. Open the Redeem Code screen.
2. Enter your code (codes are automatically converted to uppercase).
3. Tap/Click "Redeem".

Codes can:

- Activate a plan (Pro, Unlimited, or Lifetime) for a specific duration.
- Add audio minutes to your account.

A confirmation message shows what was applied (plan name and duration, or number of minutes added). If the code is invalid, expired, or already redeemed, an error message explains the reason.

**Important: Your purchase from xnote.ai will not be active on your account until you enter the redeem code. Make sure to redeem your code as soon as you receive it.**

## 4.7 Manage & Restore Purchases

Manage Subscription:

- iOS: Opens App Store subscription management.
- Android: Opens Google Play subscription management.
- Shopify purchases: Opens [xnote.ai/account](https://xnote.ai/account).

From the store, you can change your billing period, upgrade/downgrade your plan, or cancel your subscription.

Restore Purchases:

If you previously purchased a subscription on a different account or reinstalled the app, use "Restore Purchases" on the Subscription screen (see 2.18.6). XNote will check your Apple ID or Google Play account for active subscriptions and transfer them to your current account after confirmation.

# 5. Use Cases

## 5.1 Student Lecture to Exam Prep

**Persona:** Laura, 3rd-year Law student. Takes handwritten notes in class, needs to review and study efficiently.

**Scenario:** Constitutional Law lecture, 90 minutes.

1. Before class : Opens XNote, pen is auto-connected (cap off). Primary notebook is set to "Constitutional Law" ([see 2.4 / 3.5](#)).
2. During class : Writes notes with the smart pen. Simultaneously starts a manual audio recording from the app ([see 2.8.1](#)). Handwriting is synced to the correct page in real-time.
3. After class : Recording is transcribed automatically ([see 2.8.3 / 3.9.2](#)). She opens the page and sees both her handwriting via the canvas and the full transcript side by side ([see 2.6.6 / 3.7.6](#)).
4. Studying : Opens AI Chat, mentions the lecture page ([see 2.9.2 / 3.10.2](#)), and asks:
  - "Summarize this lecture in key points" ([see 2.9.3 / 3.10.3](#))
  - "Generate flashcards from this page" ([see 2.9.4 / 3.10.4](#))
5. Organizing : Adds the page to the "Midterm Prep" folder ([see 2.14.4 / 3.15.4](#)), tags it with #constitutional and #midterm ([see 2.14.6 / 3.15.6](#)). Creates a task: "Review constitutional amendments" with a due date ([see 2.11.2 / 3.12.2](#)).
6. Sharing : Exports the page as PDF ([see 2.15.5 / 3.16.4](#)) and shares the recording link with a classmate who missed the lecture ([see 2.15.2 / 3.16.2](#)).

## 5.2 Lawyer Client Meeting to Case File

Persona: Richard, corporate lawyer. Meets clients frequently, needs accurate records and follow-up tracking.

1. Before meeting : Google Calendar event synced to XNote (see [2.12.2](#) / [3.13.2](#)). Meeting Bot is scheduled to join the video call (see [2.12.4](#) / [3.13.4](#)).
2. During meeting : Meeting Bot records and transcribes the call with speaker identification (see [2.8.5](#) / [3.9.4](#)). Richard takes handwritten notes on key legal points in his "Client Meetings" notebook.
3. After meeting : Reviews transcript with speaker labels. Links his handwritten page to the recording for cross-reference (see [2.8.7](#) / [3.9.6](#)).
4. Action items : AI Chat extracts action items from the transcript (see [2.8.6](#) / [3.9.5](#)). Creates tasks: "Draft NDA by Friday", "Request financial documents" (see [2.11.2](#) / [3.12.2](#)). Tasks sync to Todoist (see [2.11.4](#) / [3.12.4](#)).
5. Automation : A workflow triggers: when a new recording is processed, send a summary to the #legal-team Slack channel automatically (see [2.13.2](#) / [3.14.2](#)).
6. Archiving : Adds pages to "Acme Corp Case" folder (see [2.14.4](#) / [3.15.4](#)), tags with #nda and #active-case (see [2.14.6](#) / [3.15.6](#)). Exports full notebook as DOCX for the case file (see [2.15.4](#)).

## 5.3 Product Manager Sprint Planning to Stakeholder Update

Persona: Karen, PM at a tech startup. Runs weekly sprint planning and reports to stakeholders.

1. Sprint planning : Joins the team call. Meeting Bot records the session (see [2.8.2](#) / [3.9.1](#)). She sketches a feature flow diagram in her notebook during the discussion. Uses different pen colors to distinguish components (see [2.6.6](#) / [3.7.6](#)).
2. After meeting : AI Chat summarizes the meeting by speaker (see [2.9.3](#) / [3.10.3](#)). She asks: "List all decisions made and who owns them." Creates tasks for each owner (see [2.11.2](#) / [3.12.2](#)).
3. Mid-week check : Opens AI Chat, mentions multiple pages from the week (see [2.9.2](#) / [3.10.2](#)). Asks: "What are the open blockers across these meetings?" Gets a cross-page analysis.
4. Stakeholder update : Asks AI Chat: "Generate a chart showing task completion this sprint" (see [2.9.6](#) / [3.10.6](#)). Exports the chart and summary. Shares the recording link with stakeholders who couldn't attend (see [2.15.2](#) / [3.16.2](#)).
5. Organization : Tags pages with #sprint-24 and #q1-roadmap (see [2.14.6](#) / [3.15.6](#)). Moves completed sprint pages to the "Archived Sprints" folder (see [2.14.1](#) / [3.15.1](#)).

## 5.4 Sales Team Lead Automated Note Distribution

Persona: Daniel, B2B SaaS sales team lead. Manages 4 sales reps. Needs client meeting notes distributed automatically to the right people.

1. Folder structure : Creates folders per deal stage: "Prospecting", "Negotiation", "Closing", "Won/Lost" (see [2.14.1](#) / [3.15.1](#)).
2. Automation 1 : Slack alert on new notes: Trigger: Note updated (new content only). Condition: text contains "proposal". Action: Send Slack message to #sales-pipeline with {{content}}. Every time a rep writes a note mentioning "proposal", the team gets notified instantly (see [2.13.2](#) / [3.14.2](#)).
3. Automation 2 : Client summary email: Trigger: Note updated. Condition: text contains "follow-up". Actions: (1) Gmail send an AI-generated summary to the client's email, (2) Google Drive save the page as PDF to the shared "Client Docs" folder (see [2.13.2](#) / [3.14.2](#)).
4. Automation 3 : Weekly pipeline report: Trigger: Time-based, every Monday 9:00 AM. Content: "Negotiation" notebook. Action: Gmail send AI-summarized weekly overview to the VP of Sales (see [2.13.2](#) / [3.14.2](#)).
5. Monitoring : Checks Automation History to verify all emails and Slack messages were delivered. Sees a failed action (Slack token expired), reconnects the service, automation resumes (see [2.13.6](#) / [3.14.6](#) and [2.13.5](#) / [3.14.5](#)).
6. Scaling : Starts with 3 automations on Pro plan. As the team grows, upgrades to Unlimited to add more workflows (see [4.1](#) and [4.5](#)).

## 5.5 Content Creator Automated Publishing Pipeline

Persona: Sophie, solo content creator. Writes blog posts and newsletters by hand, needs an automated pipeline from draft to publish.

1. Writing : Writes blog draft in "Content Drafts" notebook. Tags the page with #blog and #draft (see [2.14.6](#) / [3.15.6](#)).
2. Automation 1 : Auto-backup drafts: Trigger: Note updated. Action: Google Drive save as DOCX to "Blog Drafts" folder. Every edit is automatically backed up (see [2.13.2](#) / [3.14.2](#)).
3. Automation 2 : Editor notification: Trigger: Task created. Condition: text contains "review". Action: Slack DM to her editor with the task details (see [2.13.2](#) / [3.14.2](#)).
4. Automation 3 : Weekly content calendar: Trigger: Time-based, every Friday 10:00 AM. Content: "Content Drafts" notebook. Actions: (1) Gmail AI-summarized list of all drafts written this week sent to herself, (2) Google Tasks create a task "Plan next week's content" (see [2.13.2](#) / [3.14.2](#)).
5. Automation 4 : Publish-ready alert: Trigger: Note updated (new content only). Condition: text contains "final". Actions: (1) Google Drive export as PDF to "Ready to Publish" folder, (2) Gmail send to newsletter platform with {{content}}, (3) Slack post to #content-published (see [2.13.2](#) / [3.14.2](#)).
6. Review : Opens Automation History. Sees 12 executions this week: 8 Drive backups, 2 Slack DMs, 1 weekly summary, 1 publish alert. All completed successfully (see [2.13.6](#) / [3.14.6](#)).

## 5.6 Operations Manager Task-Driven Team Coordination

Persona: Sarah, operations manager at a logistics company. Coordinates daily tasks across warehouse, shipping, and support teams.

1. Morning planning : Opens XNote Home, reviews Tasks Overview (see [2.5.5](#) / [3.6.5](#)). Filters by "Due Today" to see all urgent items across projects (see [2.11.1](#) / [3.12.1](#)).
2. During the day : Writes meeting notes by hand. Spots action items in her notes, creates tasks directly: "Reorder packaging supplies due March 28", "Update shipping SLA document high priority" (see [2.11.2](#) / [3.12.2](#)).
3. Todoist sync : All tasks sync bidirectionally with Todoist, where her team also works. A warehouse team member completes "Reorder packaging supplies" in Todoist it's instantly marked done in XNote too (see [2.11.4](#) / [3.12.4](#)).
4. Tracking : Uses Sort by priority to focus on high-priority items first. Searches tasks for "SLA" to find all related action items across notebooks (see [2.11.3](#) / [3.12.3](#)).
5. Weekly review : Filters by "Completed" to see what got done this week. Filters by "Overdue" to follow up on blockers. Moves completed project pages to the "Archived" folder (see [2.14.1](#) / [3.15.1](#)).

## 5.7 Consultant Event-Driven Client Schedule

Persona: James, independent management consultant. Juggles 5+ client engagements with overlapping schedules.

1. Sync : Google Calendar integration pulls all client meetings, workshops, and deadlines into XNote's calendar view (see [2.12.2](#) / [3.13.2](#)).
2. Weekly planning : Opens Calendar View, switches between week and month to see workload distribution (see [2.12.1](#) / [3.13.1](#)). Checks Upcoming Events on Home for today's and tomorrow's schedule at a glance (see [2.5.6](#) / [3.6.6](#)).
3. Before a meeting : Taps the event to see Event Details (see [2.12.3](#) / [3.13.3](#)). Links relevant notebook pages (past notes from this client) to the event so everything is one tap away during the call.
4. After a meeting : Opens the linked pages, reviews his handwritten notes alongside the event details. Creates follow-up tasks with due dates from the event context (see [2.11.2](#) / [3.12.2](#)).
5. Month-end : Uses List View filtered by a specific client to see all meetings held that month (see [2.12.1](#) / [3.13.1](#)). Exports linked pages as PDF for the client's monthly activity report (see [2.15.5](#) / [3.16.4](#)).

## 5.8 Medical Student AI-Powered Study Sessions

Persona: Emily, 2nd-year medical student. Writes dense anatomy and pharmacology notes by hand, needs to process large volumes for exams.

1. Note-taking : Writes detailed anatomy notes across 15+ pages in her "Anatomy" notebook. Diagrams, labels, definitions all handwritten on the canvas (see [2.6.6](#) / [3.7.6](#)).
2. Quick review : Opens AI Chat, mentions a specific page (see [2.9.2](#) / [3.10.2](#)). Asks: "Summarize the key structures and their functions from this page." Gets a structured summary (see [2.9.3](#) / [3.10.3](#)).
3. Exam prep : Mentions 4 pages from the cardiovascular chapter at once. Asks: "Generate flashcards covering all terms and definitions across these pages." Gets 30+ Q&A pairs (see [2.9.4](#) / [3.10.4](#)).
4. Cross-topic connections : Asks AI Chat: "Compare the drug interactions I wrote on page 12 with the side effects on page 18. Are there any contradictions?" Gets a cross-page analysis.
5. Weak spots : Searches for "renal system" using Topic-Based Search (see [2.10.2](#) / [3.11.2](#)). Finds all relevant pages, mentions them in chat, asks: "Which concepts on these pages are most likely to appear as exam questions?"
6. Review history : Opens Chat History to revisit the flashcards and summaries generated last week without regenerating them (see [2.9.7](#) / [3.10.7](#)).

## 5.9 Business Analyst Data Interpretation & Reporting

Persona: Marco, business analyst at a multinational firm. Collects data from handwritten workshop sessions across different countries.

1. Data collection : Facilitates workshops in Berlin and Istanbul. Writes participant feedback, metrics, and observations by hand in separate notebooks (see [2.6.2](#) / [3.7.2](#)).
2. Translation : Opens AI Chat, mentions the pages from the Istanbul workshop (see [2.9.2](#) / [3.10.2](#)). Asks: "Translate all content on these pages to English." Gets the full translated text (see [2.9.5](#) / [3.10.5](#)).
3. Visualization : Mentions pages from both workshops. Asks: "Generate a bar chart comparing the satisfaction scores from Berlin vs. Istanbul." Follows up: "Now show it as a trend line over the 3 workshop days" (see [2.9.6](#) / [3.10.6](#)).
4. Insight extraction : Asks: "What are the top 5 recurring complaints across all pages tagged #feedback?" Gets a prioritized list with references to source pages.
5. Reporting : Tags all analysis pages with #q1-report (see [2.14.6](#) / [3.15.6](#)). Exports the charts and translated summaries as PDF (see [2.15.5](#) / [3.16.4](#)). Shares key pages via link recipients view the content without needing an XNote account (see [2.15.1](#) / [3.16.1](#)).
6. Next quarter : Opens Chat History (see [2.9.7](#) / [3.10.7](#)), revisits Q1 analysis. Mentions Q1 and Q2 pages together, asks: "Compare Q1 and Q2 feedback trends." Gets a quarter-over-quarter analysis.

## 5.10 Researcher Finding Insights Across Field Notes

Persona: Dr. Helen, environmental scientist. Has 6 months of handwritten field observations across 3 notebooks (200+ pages).

1. Tagging system : Tags every page during fieldwork: #water-sample, #soil, #site-north, #site-south, #anomaly, #seasonal (see [2.14.6](#) / [3.15.6](#)).
2. Exact match : Needs to find a specific pH reading she wrote weeks ago. Uses Full-Text Search, types "pH 6.4". Finds the exact page instantly among 200+ pages (see [2.10.1](#) / [3.11.1](#)).
3. Conceptual search : Remembers writing about contamination patterns but not the exact words. Uses Topic-Based Search: "pollution levels near river." XNote finds relevant pages even though she wrote "contamination", "toxin readings", and "chemical runoff" (see [2.10.2](#) / [3.11.2](#)).
4. Narrowing down : Applies Tag-Based Filtering: selects #site-north + #anomaly. Now sees only the 7 pages where she recorded unusual readings at the north site (see [2.10.3](#) / [3.11.3](#)).
5. Combined workflow : Opens 3 of those filtered pages in AI Chat (see [2.9.2](#) / [3.10.2](#)). Asks: "What patterns do you see across these anomaly readings?" Gets a cross-page analysis highlighting a seasonal trend she hadn't noticed.
6. Ongoing use : Saves the search to Recent Searches for quick access (see [2.10.4](#) / [3.11.4](#)). Repeats the tag-filtered search monthly as new field data comes in, tracking whether the anomaly persists.

# 6. Frequently Asked Questions (FAQ)

## 6.1 Smart Pen & Hardware

### How long does the battery last?

On a full charge, the smart pen lasts up to 17 hours of continuous use.

### How long does it take to fully charge?

A full charge takes 2–3 hours. The LED stays red while charging and turns green when complete.

### What do the LED indicator colors mean?

The LED communicates different states through color and behavior. See Section [1.2](#) for the full LED Color Status Key, or visit our support page at [support.xnote.ai](https://support.xnote.ai).

### Do I need the app open for the pen to work?

No. The smart pen can store up to 1,000 pages internally. Your notes will sync automatically the next time you connect to the app.

### Can I connect more than one pen to my phone?

Yes, multiple pens can be paired with the same device. Turn off other pens when switching between them to avoid connection conflicts.

### How do I replace the ink refill?

Pull the pen tip firmly to remove the old refill. Insert any standard D1-type refill. Replacement refills (0.8mm, black) are also available on our website.

### Is XNote only compatible with special notebooks?

Yes. XNote works with our dot-pattern notebooks, which are available in three sizes: Mini, Standard, and Large. When your notebook is finished, you can order a new one from [xnote.ai](https://xnote.ai).

### How do I disconnect the XNote Smart Pen?

Tap the pen status button in the top-left corner of the app. This will immediately disconnect your device from the XNote Smart Pen.

### How many languages does XNote AI support?

XNote supports 53 languages for handwriting recognition. The primary interface language is English.

### **What should I do if my XNote Smart Pen doesn't turn on?**

Make sure the pen is charged. Plug in the charging cable and check if the LED turns red. If there is no LED response, press and hold the power button for 10 seconds to reset the pen, then try charging again. See Section [1.4](#) for details.

### **What should I do if my pen won't connect to the app via Bluetooth?**

Try the following steps:

1. Make sure the pen is charged and uncapped (LED should flash blue).
2. Check that Bluetooth is enabled on your device.
3. On Android, make sure Location permission is also granted.
4. Bring the pen close to your device.
5. Close and reopen the XNote app.
6. If still not connecting, reset the pen by pressing and holding the power button for 10 seconds. See Section [2.3](#) for full pairing instructions.

### **What should I do if my handwriting is not being recognized?**

Check the following:

1. Make sure you are writing on an XNote dot-pattern notebook (not regular paper).
2. Hold the pen so the optical sensor faces downwards at a natural angle ( $-20^{\circ}$  to  $+40^{\circ}$ ).
3. Do not cover the optical sensor with your fingers.
4. Avoid writing in direct sunlight.
5. Do not write on the edge of the page where there is no dot code.
6. Check if the optical sensor is clean — if dirty, wipe with a soft cloth. If the LED shows a pink solid light with alarms, there is an optical sensor issue. See Section [1.5](#) for details.

### **What should I do if the pen's battery drains too fast?**

The pen lasts up to 17 hours on a full charge with continuous use. If battery drains unusually fast:

1. Fully charge the pen (LED turns green, then off).
2. Reset the pen by pressing and holding the power button for 10 seconds.
3. Check the auto-power-off setting — a shorter time conserves battery (Settings → Pen Settings). Default is 6 hours.
4. If the pen has not been used for a long period and was completely discharged, the battery life may be reduced. Charge the pen regularly to maintain battery health.

### **What does "Low storage" mean on the pen?**

The LED flashes yellow when the pen's internal storage is running low. Connect the pen to the XNote app to sync your notes and free up space. The pen can store up to 1,000 pages internally.

## **6.2 Account & Sign In**

### **How do I create an account?**

Open the XNote App and tap "Sign Up." You can register with your email, Google account, or Apple ID (iOS only). See Section [2.1.1](#) for detailed steps.

### **What if I forgot my password?**

Tap "Forgot Password" on the Sign In screen. A verification code will be sent to your email. Enter the code, then set a new password. See Section [2.1.3](#).

### **How do I change my password?**

Go to Settings → Your Account → Change Password.

### **How do I change the app language?**

Go to Settings → Language and select your preferred language. XNote supports multiple languages.

### **How do I delete my account?**

Go to Settings → scroll to the bottom → Delete Account. Warning: All personal data associated with your account will be permanently removed. See Section [2.17.10](#).

### **How do I update the XNote AI app?**

On iOS, open the App Store, tap your profile icon in the top-right corner, scroll down to find XNote, and tap "Update" if available. On Android, open the Google Play Store, tap your profile icon, select "Manage apps & device", and check the "Updates available" section for XNote.

## **6.3 Notebooks, Pages & Sync**

### **How does XNote convert my handwriting to digital text?**

XNote uses advanced AI to recognize your handwritten notes and convert them into precise, searchable digital text powered by OCR (Optical Character Recognition) optimized for multiple languages.

### **What happens when I sign in on a new device?**

XNote automatically syncs all your notebooks, pages, and settings to the new device. An initial sync screen is displayed during this process. See Section [2.1.4](#).

### **Can I share my notes with others?**

Yes. You can share individual pages or recordings via a link, or export pages in multiple formats (PDF, PNG, SVG, DOCX, Markdown). See Section [2.15](#).

### **How can I rename, delete, or restore a notebook?**

You can manage your notebooks directly from the XNote app. Use the three-dot menu on any notebook card to rename, delete, or restore. See Section [2.6](#) for detailed steps.

### **Can I use the pen without an internet connection?**

Yes. The pen records your handwriting offline and stores it internally (up to 1,000 pages). When you reconnect to the app, your notes sync automatically. AI features (transcription, summaries, chat) require an internet connection.

### **What should I do if offline sync fails or gets stuck?**

If sync seems stuck, try the following steps:

1. Close the app completely.
2. Press and hold the pen's power button until the LED turns off.
3. Turn the pen back on, reopen the app, and try syncing again. If some pages succeed while others fail, you can retry the failed pages individually. Do not close the app while saving is in progress, this may result in data loss. Make sure your device has sufficient storage space before syncing.

## **6.4 Audio & Transcription**

### **How does audio recording work without a microphone on the pen?**

Audio recording is handled entirely through the XNote App on your device. You can start a manual recording from the Home screen or send a meeting bot to Google Meet, Zoom, or Microsoft Teams. See Section [2.8](#).

### **How many transcription minutes do I get?**

This depends on your plan. You can also purchase additional minutes as add-ons. See Section [4](#).

### **Can I link my handwritten notes to a recording?**

Yes. You can associate specific notebook pages with an audio session so your notes and transcription are connected. See Section [2.8.7](#).

## What should I do if the transcription quality is poor?

Check the following:

1. Make sure you are recording in a quiet environment or close to the speaker.
2. Verify the correct transcription language is set (Settings → Calendar Settings or Recording settings).
3. For meeting recordings, ensure the Meeting Bot has proper access to the call audio.
4. Try a shorter test recording first to verify quality.

## Can I import audio files from other apps?

No. XNote does not currently support importing external audio files. You can record audio directly through the app using your device's microphone (see [2.8.1](#)) or by sending a Meeting Bot to a Google Meet or Zoom call (see [2.8.2](#)).

## What happens if I run out of audio minutes?

Audio minutes are only consumed during transcription, not during recording. You can always record audio regardless of your remaining quota. When you start transcription:

- If you have no minutes remaining, transcription will be blocked. You will need to purchase additional minutes or upgrade your plan.
- If you have some minutes remaining but less than the recording duration, XNote will notify you before proceeding. For example, if your recording is 60 minutes but you only have 2 minutes of quota left, only the first 2 minutes will be transcribed. You can choose to proceed with this partial transcription or purchase additional minutes to transcribe the full recording.

For the Meeting Bot, audio minutes are checked before the bot is sent to the meeting. If you have less than 1 minute remaining, the bot will not be scheduled.

See Section [4.3](#) for add-on minute packages.

# 6.5 AI Features

## What can I do with AI Chat?

You can ask questions about your notes, request summaries, generate flashcards, translate content, and even create charts all through a conversational interface. You can also mention specific pages to focus the AI on particular content. See Section [2.9](#).

## How does search work?

XNote offers full-text search across all your digitized notes, topic-based search for finding related content, and tag-based filtering. See Section [2.10](#).

### **Are my notes used to train AI models?**

No. Your notes are processed to provide features like transcription, summaries, and search, but they are not used to train external AI models.

## **6.6 Integrations & Automations**

### **Which integrations does XNote support?**

XNote integrates with Google Calendar, Todoist, Slack, Zapier, Zoom, Google Drive, and Gmail. See Sections [2.11.4](#), [2.12.2](#), [2.13.5](#).

### **What are automations?**

Automations are trigger-based rules that connect XNote with external services. For example, you can automatically send a Slack message when a new task is detected in your notes, or create a Google Calendar event when you write a date. See Section [2.13](#).

### **How many automations can I create?**

This depends on your plan. See Section [4](#).

## **6.7 Subscription & Billing**

### **What plans are available?**

XNote offers Starter (free), Pro, and Unlimited plans. A Lifetime option is also available for previous customers. See Section [4.1](#).

### **Can I buy additional audio minutes?**

Yes. Add-on audio minutes are available in packs of 600, 3,000, and 6,000 minutes, valid for 12–24 months from activation. See Section [4.3](#).

### **What happens when my subscription expires?**

Your account falls back to your base plan. You keep access to all your existing notes, pages, and recordings. However, features tied to your paid plan (additional audio minutes, workflows) will be limited to the base plan's quota. See Section [4.5](#).

### **What happens to my add-on minutes if I cancel my subscription?**

Add-on minutes never expire and remain in your account regardless of your subscription status. Only monthly subscription minutes reset and are affected by plan changes.

## 6.8 Warranty & Orders

### **What is the warranty and after-sales policy for XNote?**

Customers of XNote enjoy a 12-month warranty service starting from the date of purchase. To avail of the warranty service, customers must provide a valid order number.

Please note that the warranty service applies specifically to the technological components of XNote, such as the smart pen, and not to the notebooks themselves.

The warranty service applies if:

The smart pen is not dismantled, repaired, maintained, resold, or modified without permission.

The smart pen is not operated in an abnormal environment.

The smart pen is not damaged due to a violation of the user's guide.

The smart pen has not experienced a collision, falling, or bending due to improper storage or faults, and has not suffered significant deformations due to liquid exposure in humid places.

### **How can I track my orders?**

To track your orders, click on 'Support' in the Menu Bar on the homepage of xnote.ai. Then you'll find 'Order Tracking.' Click on it and enter your order number to track your order.

Or you can track your order here: [LINK HERE](#)

### **Can I cancel my order if it has not been shipped?**

Yes, you can cancel your order before it has been shipped (before tracking information is available).